



Catalogue

Equipment for Hydrogen Peroxide Service



CONTENTS

Equipment for Hydrogen Peroxide Service

Catalogue

| | |
|--|----|
| 500mm Ultra Low Profile Manlid Assembly | 3 |
| 250mm Low Profile Burst Disc Holder | 5 |
| DN65 Super Maxi Relief Valve | 7 |
| DN50 Low Profile Breather Vent | 9 |
| DN50 Ball Valve | 11 |
| Blind Weld-in Flange | 13 |
| Appendix | |
| Bolt Torque Guide & Step Loading Procedure | 17 |
| Client Responsibilities | 19 |
| Fort Vale Worldwide | 21 |

THIS PAGE IS INTENTIONALLY BLANK



500mm Ultra Low Profile Manlid Assembly: H₂O₂

Part No: E4X-85XX013A

Specification

Nominal size
DN500

Cover

8 point with a fill pipe flange assembly & a breather vent assembly with sintered disc and low-leak cap with secondary sintered disc

Neckring/compensating ring

Thickness: 8mm
Tank radius profiling range: 950mm to 1260mm

Materials

Contact parts: 316 stainless steel
Fasteners: stainless steel swingbolts and handnuts
Fill pipe gasket & breather vent seals: PTFE
Manlid cover seal: supplied separately

Alternatives are available, refer to Fort Vale



Design Conditions

| | |
|-------------------------|---------|
| Weight: | 57.8 Kg |
| Design Pressure (MAWP): | 4 Bar |
| Test Pressure: | 6 Bar |
| Design Temperature Min: | -40°C |
| Design Temperature Max: | 200°C |

NOTE: The Design Temperature limits refer to metal parts only. The Design Conditions and Section View dimensions are for the specified part number only.

Design Codes

BS EN 14025

Section View

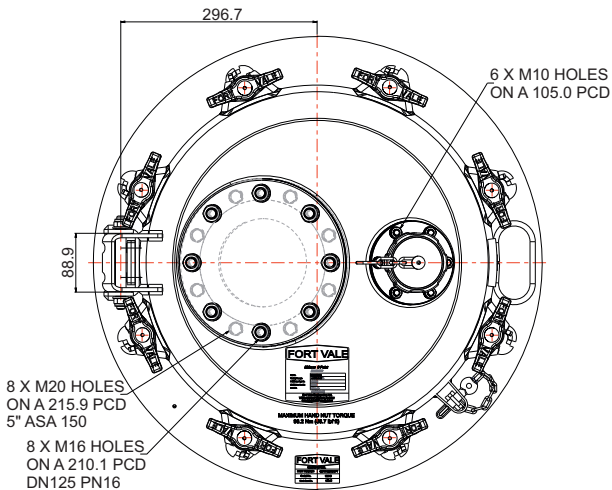
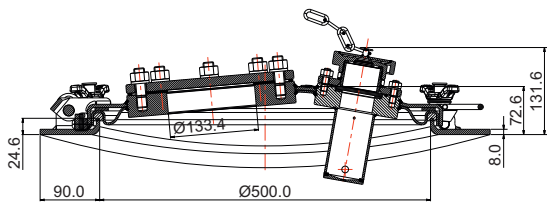



500mm Ultra Low Profile Manlid Assembly: H₂O₂

Part No: E4X-85XX013A

Parts Drawing

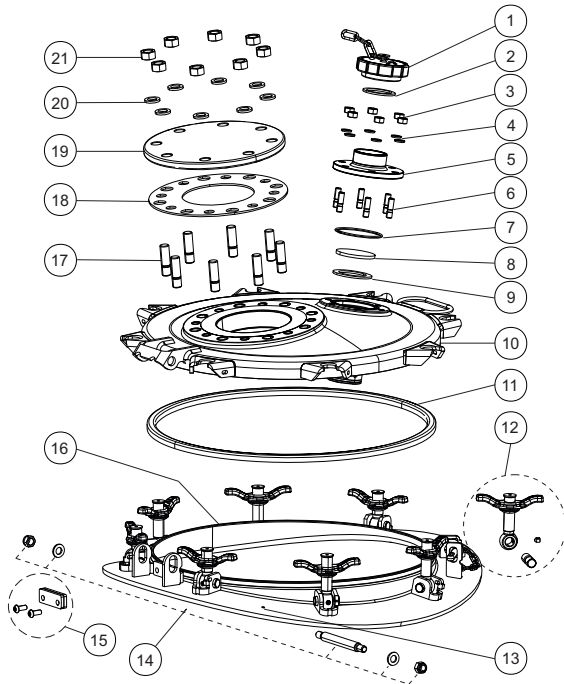

Parts List

| Item | Description | Part No. |
|------|--------------------------------|---------------|
| 1 | Breather cap assembly | 674/3040 |
| 2 | Breather cap seal | 5005-414 |
| 3 | M10 full nut (6) | 5112-002 |
| 4 | M10 spring washer (6) | 5113-002 |
| 5 | 2" BSP outlet | 674/3546 |
| 6 | M10 x 35mm stud (6) | 371/0001 |
| 7 | PTFE O ring | 5005-235 |
| 8 | Sintered disc | 865/2000 |
| 9 | PTFE gasket | 5005-435 |
| 10 | Manlid cover | 74E/1650 |
| 11 | Seal (not included) *Note | 5005-XXXX |
| 12 | Short swingbolt assy. (4) | 496/5250 |
| | Long swingbolt assy. (4) *Note | 496/5XXX |
| 13 | M6 set screw | 5111-009 |
| 14 | Hinge pin assembly | 600/1060 |
| 15 | Hinge kit *Note | 135B |
| 16 | Neckring *Note | 6EP/7403XXXPT |
| 17 | M16 x 60mm stud (8) | 368/1109 |
| 18 | PTFE fill flange gasket | 5005-411 |
| 19 | Blind flange | 674/5051 |
| 20 | M16 spring washer (8) | 5113-012 |
| 21 | M16 full nut (8) | 5112-003 |

NOTE: The specification changes the Part No.



250mm Low Profile Burst Disc Holder: Hydrogen Peroxide

Part No: 674/8680



Specification

Nominal size
250mm

Tank connection
Flanged: 12 x M20 holes on a 350.0mm PCD

Properties
Weather cowl, TIR and internal surge protection cover.
NOTE: The burst disc is not included, refer to Related Parts

Materials
Weld-in flange: 316L stainless steel
Gasket: PTFE

Alternatives are available, refer to Range or contact Fort Vale

Design Conditions

Weight: 38.7 Kg
 Design Pressure (MAWP): 4 Bar
 Design Temperature Max: 140°C
 Minimum Flow: 93045 m³/hr at 4 Barg

NOTE: The Design Conditions and Section View dimensions are for the specified part number only.

Range

| Description | Part No. |
|--------------------------------|----------|
| With surge protection cover | 674/8680 |
| Without surge protection cover | 674/8580 |

Related Parts

| Description | Part No. |
|-----------------------------------|----------------|
| 250mm burst disc: 4.5 Bar at 20°C | 865/A0450020AD |
| 250mm burst disc: 4.5 Bar at 60°C | 865/A0450060AD |
| 250mm burst disc: 6 Bar at 20°C | 865/A0600020AD |

Section View

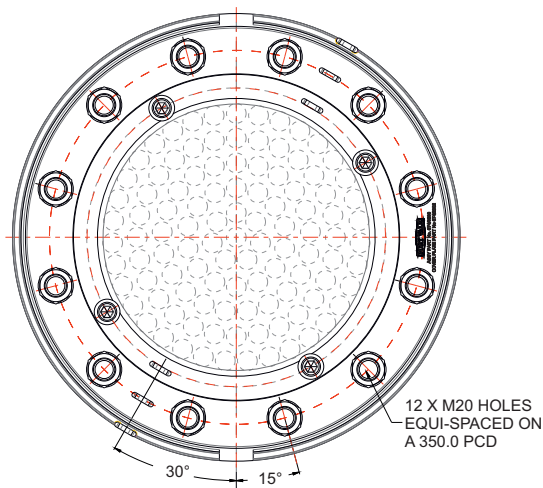
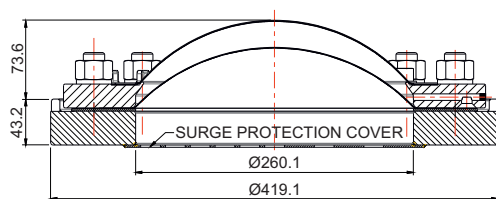



250mm Low Profile Burst Disc Holder: Hydrogen Peroxide

Part No: 674/8680

Parts Drawing

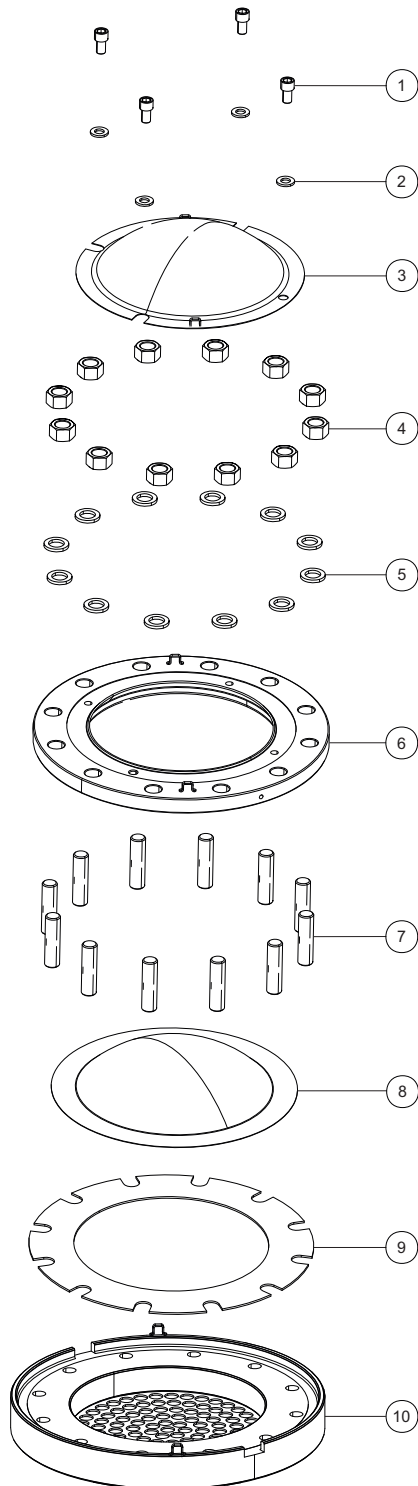

Parts List

| Item | Description | Part No. |
|------|---------------------------------|----------|
| 1 | M12 cap screw (4) | 5111-066 |
| 2 | M12 plain washer (4) | 5113-006 |
| 3 | Weather cowl | 674/2005 |
| 4 | M20 full nut (12) | 5112-011 |
| 5 | M20 spring washer (12) | 5113-016 |
| 6 | Burst disc cover plate | 674/2002 |
| 7 | M20 stud (12) | 674/8005 |
| 8 | Burst disc *Note | 865/XXXX |
| 9 | PTFE gasket | 5005-283 |
| 10 | Weld-in flange with surge cover | 674/8560 |

NOTE: The burst disc is supplied as a separate part. Please refer to Related Parts, page 1.



DN65 Super Maxi Relief Valve - Pressure/Vacuum

Part No: 010/1XXXXX - Metric Setting



Specification

Nominal size

DN65

Tank connection

Threaded: 2½" BSP

Set pressure

From 0.15 Bar to 5.15 Bar

Set vacuum

From 1 kPa to 88 kPa

Materials

Contact parts: 316 stainless steel

Pressure O ring: Fortyt

Vacuum O ring: Fortyt

Tank seal: Rubber/PTFE envelope

Alternatives are available, refer to the Design Options page

Design Conditions

| | |
|-------------------------|----------|
| Weight: | 2.9 Kg |
| Design Pressure (MAWP): | 5.2 Bar |
| Test Pressure: | 10.1 Bar |
| Design Temperature Min: | -55°C |
| Design Temperature Max: | 200°C |

NOTE: The working temperature of the pressure and vacuum O rings can change the design temperature limits. The Design Conditions and Section View dimensions are for the specified part number only.

Type Approval

Lloyd's Register

WARNING: If you install an approved relief valve accessory item, e.g. a flame arrester, cowl, burst disc or baffle, it will decrease the air flow capacity of the relief valve. Thus, you must calculate again to make sure that the decreased air flow capacity will give sufficient protection to your vessel/system. Refer to Fort Vale for more information.

Range

| Standard Settings | Part No. |
|-------------------|------------|
| 2.19 Bar & 21 kPa | 010/121921 |
| 3.31 Bar & 21 kPa | 010/133121 |
| 3.71 Bar & 21 kPa | 010/137121 |
| 4.40 Bar & 21 kPa | 010/144021 |

Related Parts

| Description | Part No. |
|--|------------|
| 2½" BSP weld-in socket | 600/1000 |
| Weld-in flange | 176/3150 |
| CNAF/PTFE gasket (adaptor flange) | 5005-398 |
| 0-7 Bar pressure gauge, brass internal parts | 921/07BBSP |
| 0-7 Bar pressure gauge, stainless steel internal parts | 920/07BBSP |
| Flame arrester *Warning | 176/2900 |
| Gauzed cowl *Warning | 176/6000 |

Section View

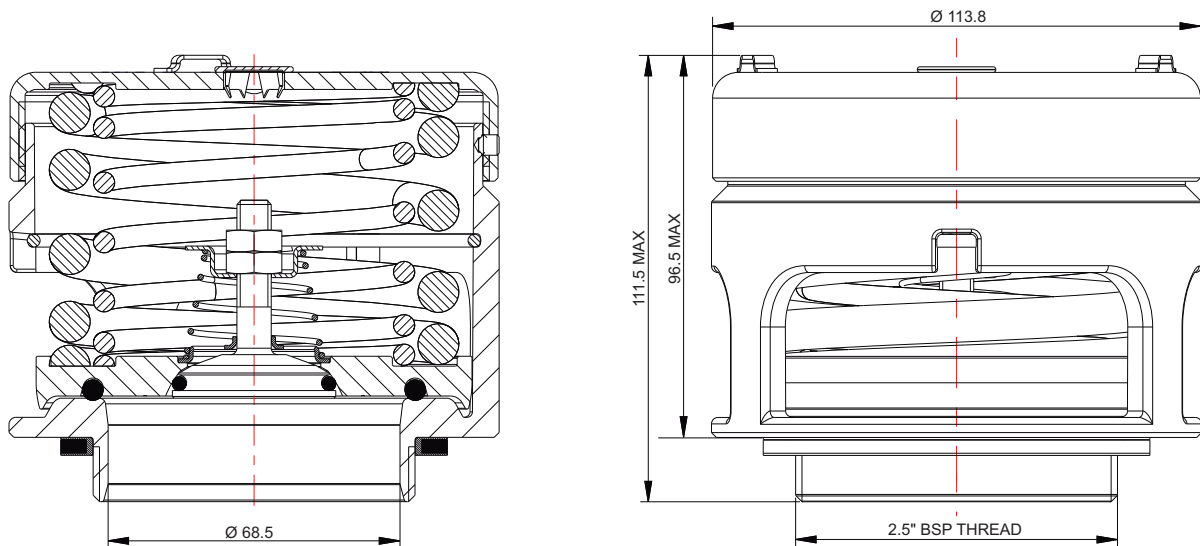



DN65 Super Maxi Relief Valve - Pressure/Vacuum

Part No: 010/1XXXXX - Metric Setting

Parts Drawing

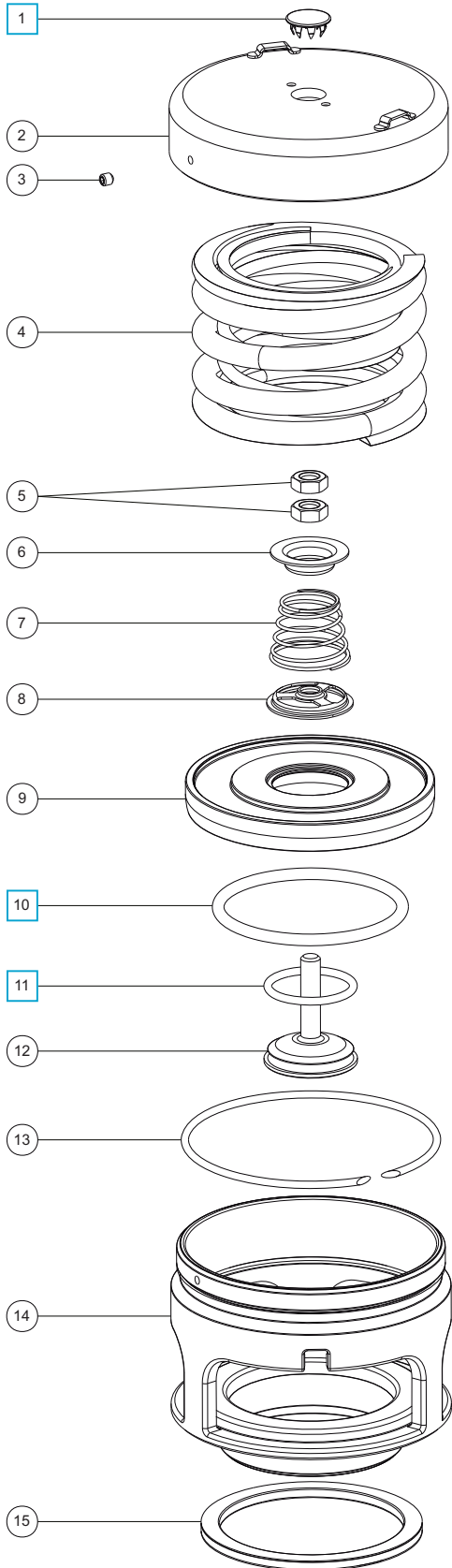

Parts List

| Item | Description | Part No. |
|------|---------------------------|------------------------------------|
| 1 | Stainless steel plug | 10978 <input type="checkbox"/> |
| 2 | Cap *Note | 1760/0005XX |
| 3 | Anti-tamper screw | 5121-001 |
| 4 | Pressure springs | Refer to Table 1 |
| 5 | M8 half nut (2) | 5112-004 |
| 6 | Vacuum spring pad | 1860/0005 |
| 7 | Vacuum spring | Refer to Table 2 |
| 8 | Spring pad | 10986/3 |
| 9 | Pressure plate *Note | 1860/005XXX |
| 10 | Fortyt pressure O ring | 5005-101 <input type="checkbox"/> |
| 11 | Fortyt vacuum O ring | 5005-108H <input type="checkbox"/> |
| 12 | Vacuum poppet | 10983V/3 |
| 13 | Retaining ring clip | 5120-067 |
| 14 | Body | 1860/0100 |
| 15 | Rubber/PTFE envelope seal | 5005-046 |

NOTE: The valve specification changes the Part No.

Table 1

| Std. Pressure Settings | Pressure Spring Part No. |
|------------------------|--------------------------|
| 2.19 Bar | 6104-0252 |
| 3.31 Bar | 6104-0112 & 6104-0252 |
| 3.71 Bar | 6104-0422 (Pair) |
| 4.40 Bar | 6104-0485 (Pair) |

Pressure springs are available from 0.15 Bar to 5.15 Bar

Table 2

| Std. Vacuum Setting | Vacuum Spring Part No. |
|---------------------|------------------------|
| 21 kPa | 7104-012 |

Vacuum springs are available from 1 kPa to 88 kPa

Seal Kit

| Description | Part No. |
|---|-----------|
| All parts marked <input type="checkbox"/> in the Parts List | 000/1PVSK |



DN50 Low Profile Breather Vent: Hydrogen Peroxide

Part No: 674/3542



Specification

Nominal size

DN50

Tank connection

Flanged: 6 x 11mm holes on a 104.9mm PCD

Outlet connection

2" BSP

Properties

With sintered disc to prevent vessel pressurisation
Low-leak cap with secondary sintered disc and chain

Materials

Contact parts: 316 stainless steel
Sintered discs: 316 stainless steel
All seals & gaskets: PTFE

Alternatives are available, refer to Range or contact Fort Vale

Design Conditions

Weight: 5.29 Kg
Design Pressure (MAWP): 4 Bar
Design Temperature Min: -40°C
Design Temperature Max: 150°C

NOTE: The Design Conditions and Section View dimensions are for the specified part number only.

Approvals

The cap is compatible with SNCF regulations

Range

| Description | Part No. |
|---------------------------------------|----------|
| Weld-in breather vent assembly | 674/3500 |
| DIN80 PN10 flanged breather vent assy | 674/3550 |

Related Parts

| Description | Part No. |
|----------------|----------|
| Weld-in flange | 176/3150 |

Section View

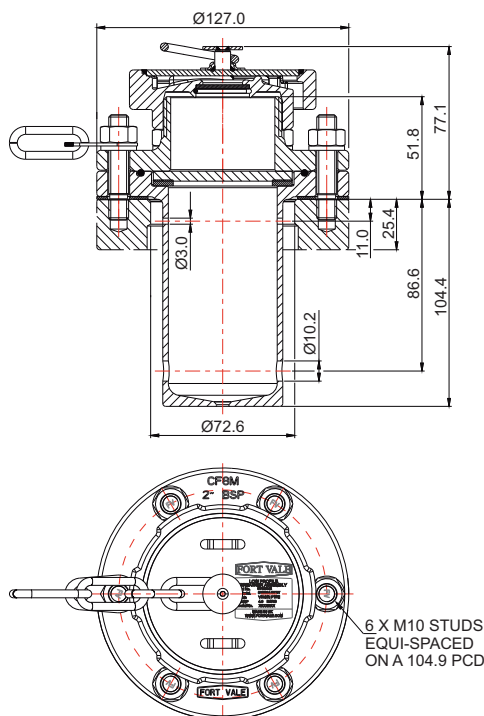



DN50 Low Profile Breather Vent: Hydrogen Peroxide

Part No: 674/3542

Parts Drawing

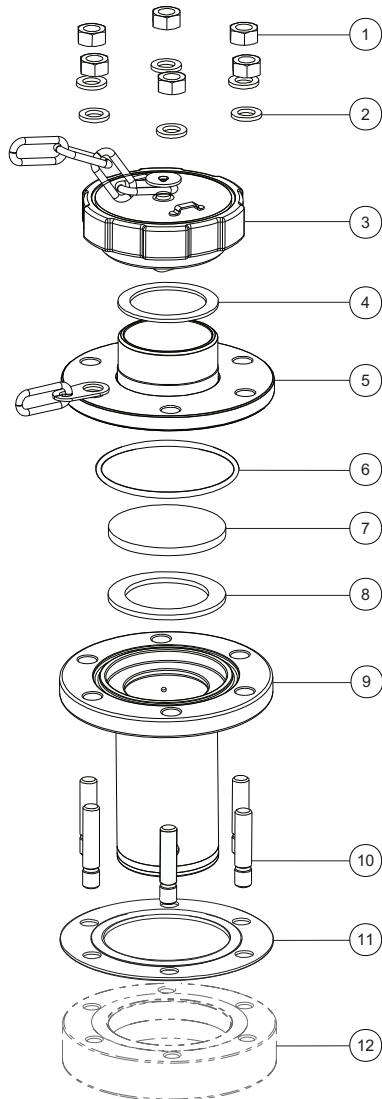

Parts List

| Item | Description | Part No. |
|------|------------------------------------|-------------|
| 1 | M10 full nut (6) | 5112-002 |
| 2 | M10 spring washer (6) | 5113-002 |
| 3 | Breather cap assembly | 674/3040 |
| 4 | PTFE breather cap seal | 5005-414 |
| 5 | 2" BSP outlet | 674/3546 |
| 6 | PTFE O ring | 5005-235 |
| 7 | Sintered disc | 865/2000 |
| 8 | PTFE breather disc seal | 5005-435 |
| 9 | Breather body | 674/3540 |
| 10 | M10 x 53mm stud (6) | 371/0008-B8 |
| 11 | PTFE inlet gasket | 5005-398P |
| 12 | Weld-in flange (supplied separate) | 176/3150 |



DN50 Ball Valve: Hydrogen Peroxide Specification

Part No: 370/0140



Specification

Nominal size

DN50

Tank connection

Flanged: 6 x 14mm holes on a 168mm PCD

Outlet/Process connection

Flanged: 4 x open slots - 2" ASA150 / 2" BSTD / DIN50 PN10

Properties

Ball with bleed hole and body with gauge connection to monitor tank pressure. Handle with TIR. With blind flange

Materials

Contact parts: 316 stainless steel

Main seal: PTFE

Alternative tank connections are available, refer to Fort Vale

Design Conditions

| | |
|-------------------------|----------|
| Weight: | 13.5 Kg |
| Design Pressure (MAWP): | 7.5 Bar |
| Test Pressure: | 13.8 Bar |
| Design Temperature Min: | -40°C |
| Design Temperature Max: | 205°C |

NOTE: The Design Conditions and Section View dimensions are for the specified part number only.

Design Code

BS EN14432

Related Parts

| Description | Part No. |
|-------------------------|-----------|
| Weld-in flange | 368/0800 |
| Stud kit | 312/1000 |
| Solid PTFE inlet gasket | 5005-222P |
| Syphon tube stub pipe | 368/0810 |
| CNAF/PTFE gasket | 5005-169 |

Section View

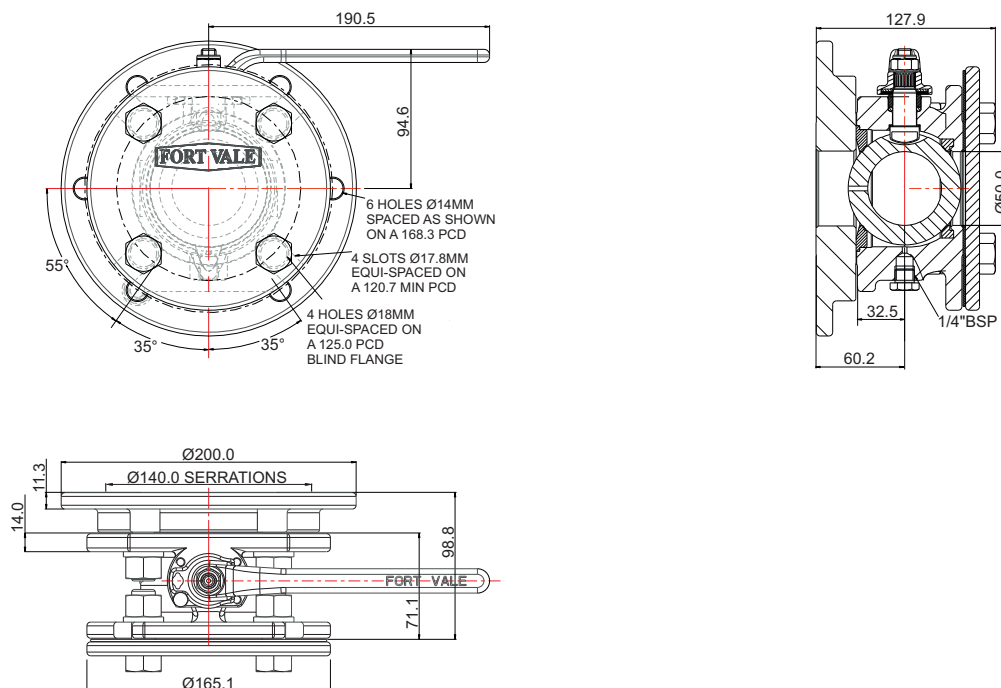



DN50 Ball Valve: Hydrogen Peroxide Specification

Part No: 370/0140

Parts Drawing

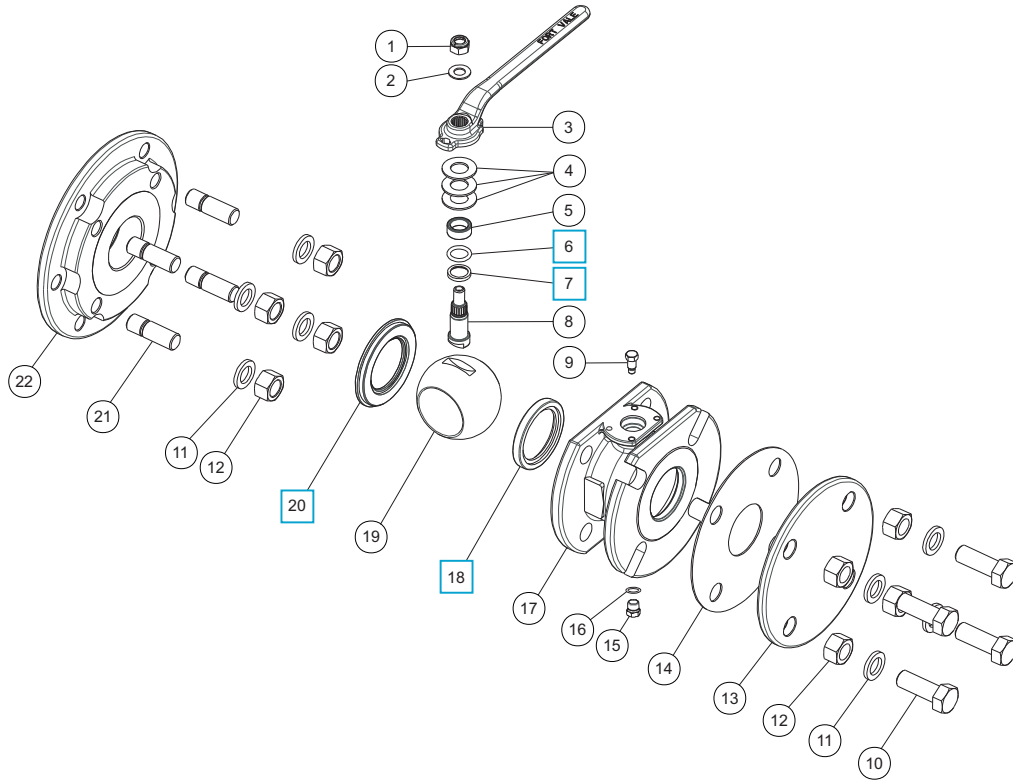

Parts List

| Item | Description | Part No. | |
|------|----------------------------|-----------|---|
| 1 | M10 self locking nut | 5112-008 | |
| 2 | M10 plain washer | 5113-009 | |
| 3 | Handle | 370/0125 | |
| 4 | 16mm Belleville washer (3) | 5113-038 | |
| 5 | Stuffing collar | 370/0103 | |
| 6 | PTFE O ring | 5005-688 | ☐ |
| 7 | Bottom bearing bush | 370/0104 | ☐ |
| 8 | Spindle | 370/0120 | |
| 9 | Stop bolt | 370/0107 | |
| 10 | M16 hex bolt (4) | 5111-031 | |
| 11 | M16 spring washer (8) | 5113-012 | |
| 12 | M16 full nut (8) | 5112-003 | |
| 13 | Blind flange | 370/4239 | |
| 14 | PTFE gasket | 5005-724P | |
| 15 | 1/4" BSP hex plug | 5128-005 | |
| 16 | PTFE O ring | 5005-048 | |
| 17 | Body | 370/0115 | |
| 18 | PTFE ball seal | 370/0102 | ☐ |
| 19 | 50mm ball | 370/3309 | |
| 20 | PTFE ball seal | 370/0105 | ☐ |
| 21 | M16 stud (4) | S0600/3 | |
| 22 | Adaptor flange | 370/0145 | |

Seal Kit

| Description | Part No. |
|--------------------------------------|----------|
| All parts marked ☐ in the Parts List | 370/01SK |



Blind Weld-in Flange: Hydrogen Peroxide

Part No: 324/9007



Specification

The blind weld-in flange is welded into the bottom of the vessel in the normal discharge valve position. If the vessel is changed to standard service, the centre section of the flange can be cut out so that a 45° discharge valve assembly can be installed.

Drilling pattern

8 x M12 holes equi-spaced on a 178mm PCD

Compatible

Standard DN80 45° Cleanflow, Uniflow, Highlift & Univalve footvalves

Material

316 stainless steel

Design Conditions

| | |
|-------------------------|----------|
| Weight | 4.5 Kg |
| Design Pressure (MAWP): | 6.67 Bar |
| Test Pressure: | 10.0 Bar |
| Design Temperature Min: | -40°C |
| Design Temperature Max: | 130°C |

NOTE: The Design Conditions and Section View dimensions are for the specified part number only.

Section View

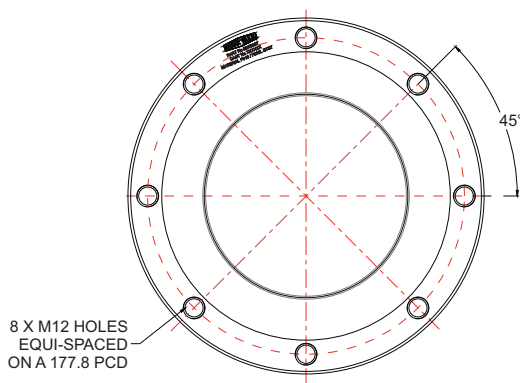
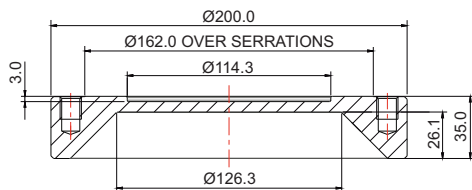

THIS PAGE IS INTENTIONALLY BLANK



APPENDIX

Catalogue

| | |
|---|--|
| A | Bolt Torque Guide & Step Loading Procedure |
| B | Client Responsibilities - Valves & Accessories |

THIS PAGE IS INTENTIONALLY BLANK



Bolt Torque Guide & Step Loading Procedure

Installation & Operating Instructions

Flange Bolting

CAUTION: Weld-distortion and too much tightening force will cause damage to a flange.

It is important not to cause damage to weld-in flanges and mating flanges. If a flange is damaged it will not give a satisfactory seal when a gasket and secondary mating flange is installed.

Bolt-stress can decrease after initial tightening. The cause can be deformation of the gasket material, particularly with soft materials such as a CNAF/PTFE envelope gasket.

Best procedure recommends that, after initial bolting, the flange joint is tightened again after a period of time. Most gasket manufacturers advise a period of 24 hours. ASME PCC-1-2000 GUIDELINES FOR PRESSURE BOUNDARY BOLTED FLANGE JOINT ASSEMBLY advises a minimum period of 4 hours.

Bolt torque calculations are based on a flat flange to within 0.15mm.

Recommended bolt torque values will be reduced if a lubrication is used.

Bolt Torque

Bolt Torque Values

Fort Vale bolt torque values are given as a reference guide only and are based on:

- the use of a CNAF/PTFE gasket.
- unlubricated fasteners.
- a flange flat to within 0.15mm.

CAUTION: If you use a different gasket material, a lubricant or a flange with distortion, you must re-calculate the torque value.

Bolt Torque Procedure

To install flanged parts correctly:

- Examine the mating flange of the part.
- If the flange is marked with a torque value, obey that torque value.
- If there is no torque value marked on the mating flange, obey the bolt torque values given in Table BT1.
- Tighten the bolts evenly in sequence. Refer to Figure BT1.
- Obey the Step Loading Procedure (ASME PCC-1-2000). Refer to the next page.

Table BT1

| Thread | Torque Value |
|--------|-------------------|
| M10 | 30 Nm (22 lbf.ft) |
| M12 | 65 Nm (48 lbf.ft) |
| M16 | 81 Nm (60 lbf.ft) |

Figure BT1

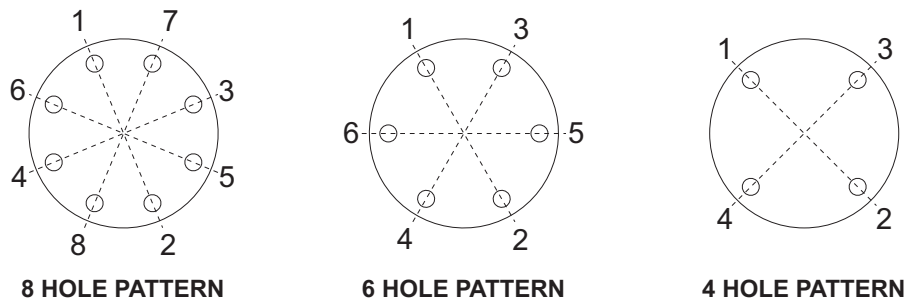



Bolt Torque Guide & Step Loading Procedure

Installation & Operating Instructions

Step Loading Procedure

To install flanged parts correctly, obey the Step Loading Procedure extract from ASME PCC-1-2000:

Install

Hand tighten, then “snug up” to 15 Nm (10 lbf.ft) to 30 Nm (20 lbf.ft) (not to exceed 20% of Target Torque). Check flange gap around circumference for uniformity. If the gap around the circumference is not reasonably uniform, make the appropriate adjustments by selective tightening before proceeding.

Round 1

Tighten to 20% to 30% of Target Torque. Check flange gap around circumference for uniformity. If the gap around the circumference is not reasonably uniform, make the appropriate adjustments by selective tightening before proceeding.

Round 2

Tighten to 50% to 70% of Target Torque. Check flange gap around circumference for uniformity. If the gap around the circumference is not reasonably uniform, make the appropriate adjustments by selective tightening before proceeding.

Round 3

Tighten to 100% of Target Torque. Check flange gap around circumference for uniformity. If the gap around the circumference is not reasonably uniform, make the appropriate adjustments by selective tightening before proceeding.

Round 4

Continue tightening the bolts, but on a rotational clockwise pattern until no further nut rotation occurs at the Round 3 Target Torque value. For indicator bolting, tighten bolts until the indicator rod retraction readings for all bolts are within the specified range.

Round 5

Time permitting, wait a minimum of 4 hr and repeat Round 4; this will restore the short-term creep relaxation/embedment losses. If the flange is subjected to a subsequent test pressure higher than its rating, it may be desirable to repeat this round after the test is completed.



Client Responsibilities - Valves & Accessories

Installation, Operation & Maintenance Instructions

Compatibility

Make sure that the function and technical specification of the valve/accessory is compatible with the vessel service conditions and the cargo. This includes, but is not limited to:

- dimensions.
- pressure/vacuum setting.
- air/vapour/liquid flow capacity.
- maximum allowable working pressure.
- test pressure.
- minimum/maximum design temperatures.
- materials of construction.

Maintenance and Inspection

Fort Vale valves and accessories have a long life if you use them correctly in compatible service conditions. It is not necessary to lubricate the parts, but we recommend that you do the inspections that follow:

Inspections at regular intervals:

1. Examine the valve to make sure there is no damage, wear or corrosion.
2. Examine the valve and adjacent area to make sure there is no leakage of cargo.
3. Examine the fasteners to make sure they are not loose.
4. Make sure the valve operates correctly.

CAUTION: If you operate the valve with very corrosive cargo, or near its temperature and/or pressure limit (very high or very low temperature and/or pressure), do the inspections more frequently.

Also, schedule regular maintenance based on how frequently the valve is used, the type of cargo and the service conditions.

Inspections after 2½ years of service or a minor incident:

1. Examine the valve to make sure there is no damage, wear or corrosion.
2. Make sure the valve operates correctly.
3. Do a pressure test on the valve.

Inspections after 5 years of service or a major incident:

1. Disassemble and clean the valve.
2. Replace all the valve seals and do a pressure test.

Replacement Parts

Do not adapt or change the valve. If you install a replacement part, it must be a genuine Fort Vale part.

WARNING: If you install a part that is not genuine, there is a risk of:

- injury to personnel.
- permanent damage to the valve.
- permanent damage to the vessel.
- valve malfunction.

External Fire

If you install the valve in an area where there is a risk of external fire, you must install compatible accessories to prevent damage to the valve.

Compatibility of Accessories

Accessory components must cause no interference with the valve's function. Accessories must be made from compatible materials that will cause no damage to the valve materials. Do not install an accessory that will cause an increased load on the valve, such as mechanical, static, dynamic or thermal load.

Mis-use

Obey the instructions and recommended procedures in the installation and operating instructions. Obey the pressure and temperature markings on the valve and on the drawing. Use the valve/accessory for its correct function only. Fort Vale accept no liability or responsibility for incorrect use of the valve/accessory.

THIS PAGE IS INTENTIONALLY BLANK



Our subsidiaries are located in:

US Office

126 N. Virginia
La Porte
TX 77571
USA

Tel: +1 281 471 8100

Fax: +1 281 471 8116

Email: ussales@fortvale.com

Head Office

Calder Vale Park
Simonstone Lane
Simonstone, Burnley
Lancashire, BB12 7ND, UK

Tel: +44 (0) 1282 687120

Fax: +44 (0) 1282 687110

Email: sales@fortvale.com

China Office

Fort Vale Engineering Shanghai Ltd
Building 11 88 Yuanshan Road
Xinzhuang Industry Park
Shanghai 201108 China

Tel: +86 21 6442 1367

Fax: +86 21 6442 1376

Email: cnsales@fortvale.com

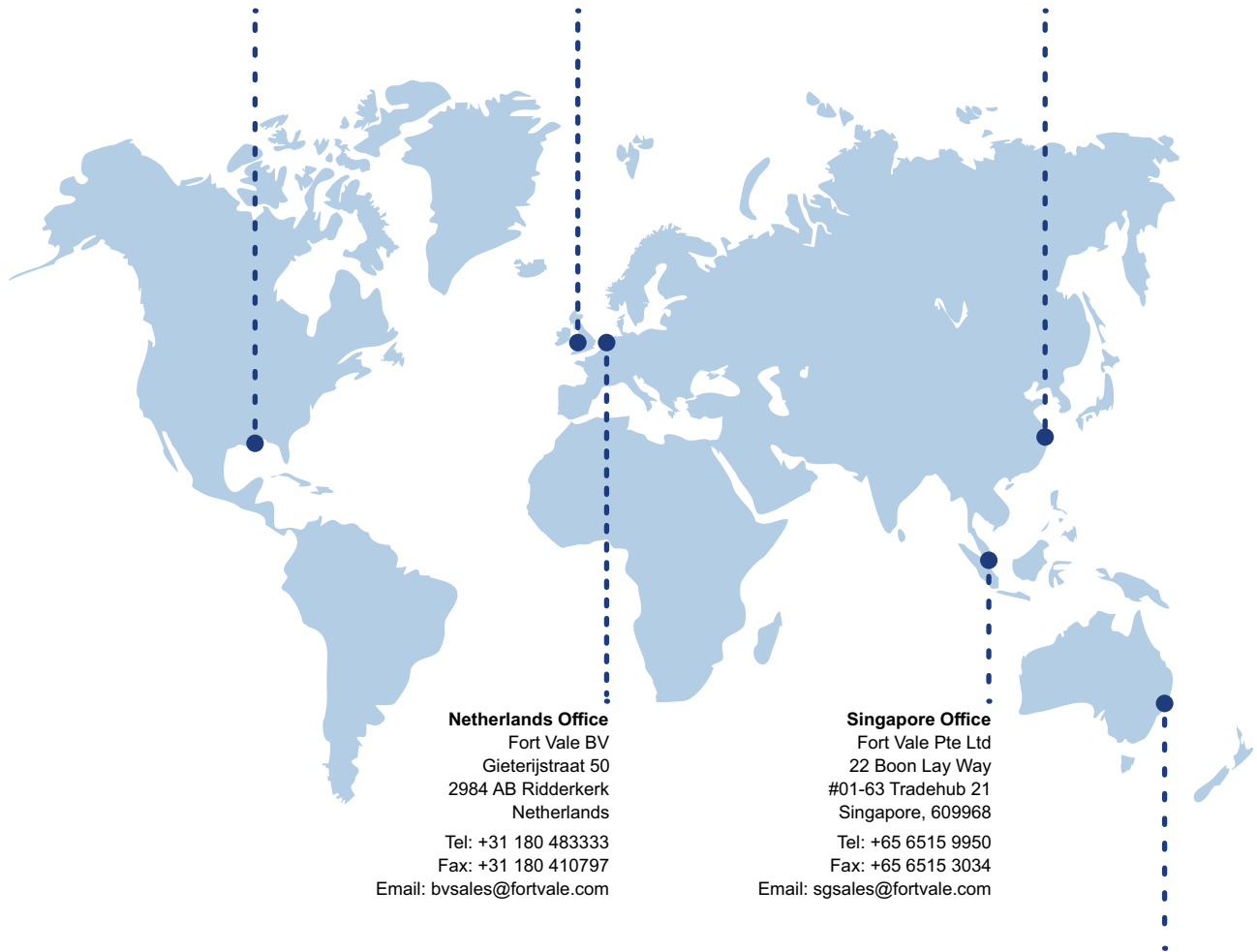

Netherlands Office

Fort Vale BV
Gieterijstraat 50
2984 AB Ridderkerk
Netherlands

Tel: +31 180 483333

Fax: +31 180 410797

Email: bvsales@fortvale.com

Singapore Office

Fort Vale Pte Ltd
22 Boon Lay Way
#01-63 Tradehub 21
Singapore, 609968

Tel: +65 6515 9950

Fax: +65 6515 3034

Email: sgsales@fortvale.com

Australia Office

Fort Vale Australia Pty Ltd
Bellwood Business Park
Unit 14, 49 Bellwood Street
Darra, Queensland, 4076

Tel: +61 7 3189 5059

Email: ausales@fortvale.com

We also have Authorised Distributors around the world to provide you with product sales and after-market services. To find your nearest distributor, please visit our website - www.fortvale.com

