



Specification

Nominal size

DN50

Tank connection

2" BSP

Set pressure

From 0.05 Bar to 1.00 Bar

Set vacuum

From 2 kPa to 17 kPa

Materials

Contact parts: 316 stainless steel

Pressure O ring: a selection of materials is available

Vacuum O ring: a selection of materials is available

Tank seal: Fortyt

Design Conditions

Weight: 0.53 Kg

For more Design Conditions, please contact Fort Vale and refer to the parts drawing.

Range

Description	Part No.
2" BSP valve: low profile body	4B/XXXXXX
2" BSP valve: standard body	4A/XXXXXX

Related Parts

Description	Part No.
2" BSP weld-in socket	600/1017
Installation C spanner	400/3000

Section View

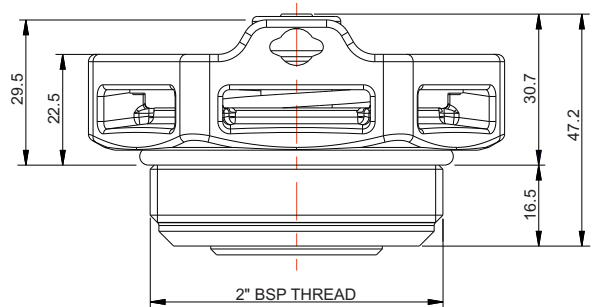
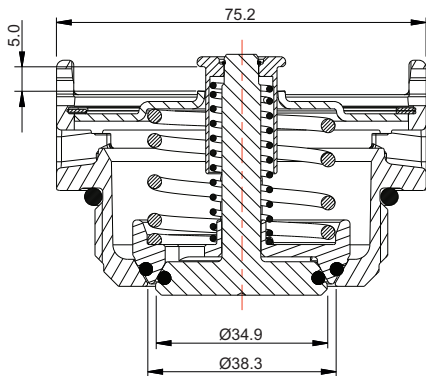

Parts Drawing

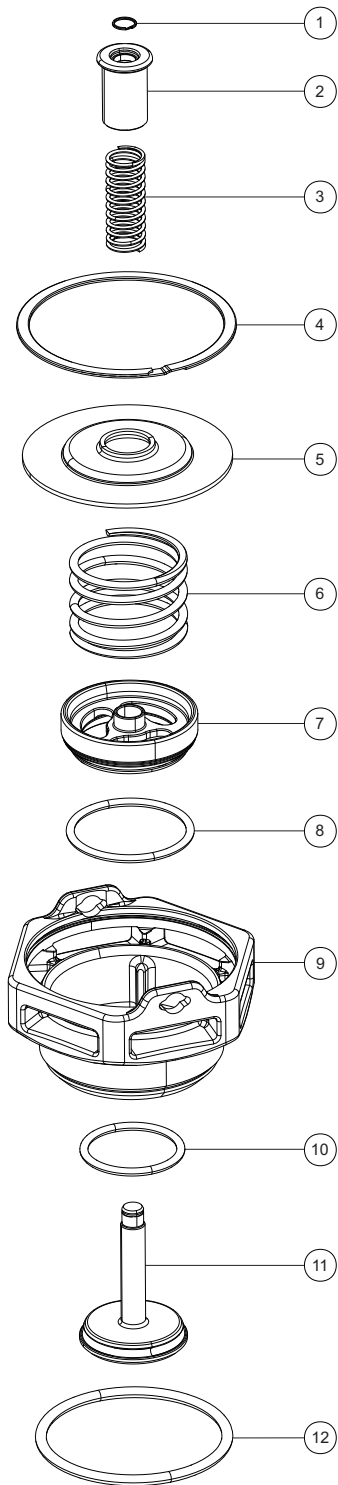

Parts List

Item	Description	Part No.
1	Retaining clip	5120-094
2	Vacuum spring guide *Note	175/0133/X
3	Vacuum spring *Note	5104-XXX
4	Retaining clip	5120-0009
5	Top cap	175/0212P
6	Pressure spring *Note	5104-XXX
7	Pressure plate	175/0219
8	Pressure O ring *Note	ORB127XX
9	Body	175/0215/1
10	Vacuum O ring *Note	ORB122XX
11	Vacuum poppet	175/0218
12	Fortyt O ring	ORB228F0

NOTE: The valve specification changes the Part No.