

Specification

Nominal size

DN100

Tank connection

Flanged: 8 x 10mm holes on a 135mm PCD

Set pressure

From 1.0 Bar to 4.0 Bar

Set vacuum

From 2 kPa to 4 kPa

Properties

With flame arrester and removable cowl

Materials

Contact parts: 316 stainless steel

Pressure O ring: Nitrile

Vacuum O ring: Nitrile

Tank seal: Nitrile

Alternatives are available, please contact Fort Vale

Design Conditions

Weight:	6.9 Kg
Design Pressure (MAWP):	4.0 Bar
Test Pressure:	6.8 Bar
Design Temp. Min/Max:	-40°C/150°C (metal parts)
Design Temp. Min/Max:	-30°C/100°C (Nitrile)

NOTE: The working temperature of the pressure/vacuum O ring material can change the design temperature limits. The Design Conditions and Section View dimensions are for the specified part number only.

Design Codes

BS EN 14596

Range

Description	Part No.
DN100, flanged connection	R01/XXXXXX
DN100, 4" NPT connection	R01/XXXXXXN

Section View

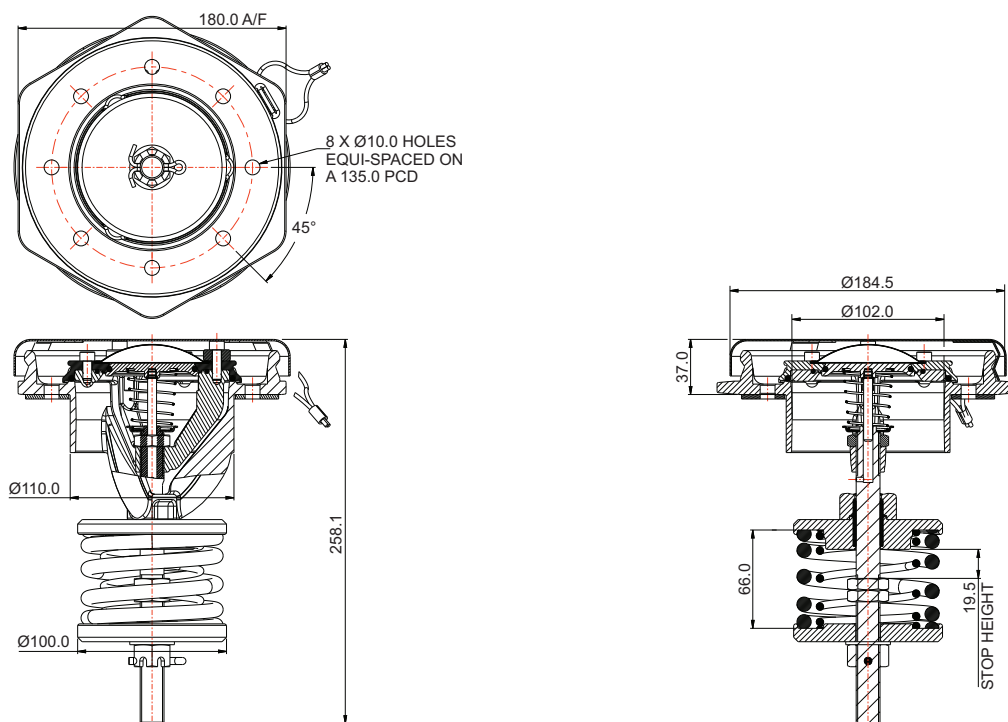

Parts Drawing

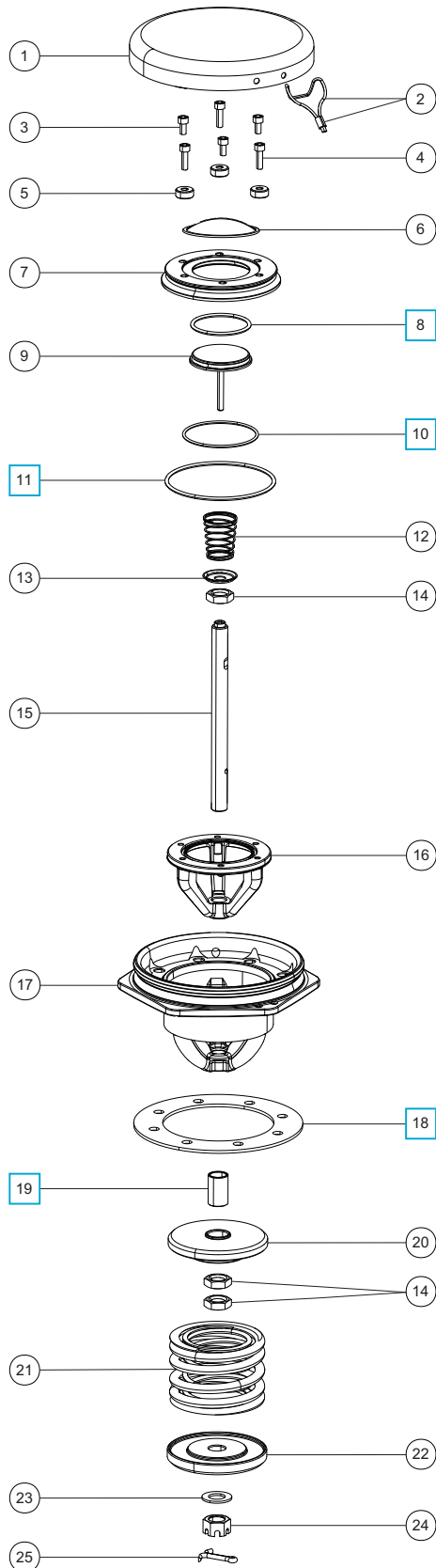

Parts List

Item	Description	Part No.
1	Cowl	176/9026
2	Stainless steel wire and ferrule	6110-005 & SF2.5
3	M6 x 12mm cap screw (3)	5111-034
4	M6 x 20mm cap screw (3)	5111-017
5	Spacer boss (3)	176/9060
6	Flame arrestor	176/9021
7	Seal clamp plate	176/9053
8	Vacuum O ring	ORB226N <input type="checkbox"/>
9	Vacuum poppet	176/9023
10	Pressure plate O ring	ORB149N <input type="checkbox"/>
11	Pressure O ring	ORB243N <input type="checkbox"/>
12	Vacuum spring *Note	5104-XXX
13	Spring pad	375/9002
14	M16 half nut (3)	5112-021
15	Stem	176/9058
16	Seal clamp cage	176/9040
17	Body	176/9030
18	Nitrile seal	176/9049N <input type="checkbox"/>
19	Stem guide bush	5008-0355 <input type="checkbox"/>
20	Top spring pad	176/9054/2
21	Pressure spring *Note	6104-XXXX
22	Bottom spring pad	176/9054/1
23	3/4" plain washer	5113-011A4
24	M16 castle nut	5112-026WS
25	Split pin	5118-043

NOTE: The valve specification changes the Part No.

Available pressure settings: 1.0 Bar to 4.0 Bar

Available vacuum settings: 2 kPa to 4 kPa

Seal Kit - All parts marked in the Parts List

Pressure/Vacuum Seal Material	Part No.
Nitrile	R01/NPVSK