

Specification

Nominal size

50mm

Tank connection

Flanged: 4 x 18mm holes on a 125mm PCD (DIN50 PN10)

Outlet/Process connection

Flanged: 4 x open slots, min. PCD: 2" BSTD

Properties

1/4" BSP gauge connection, gauge guard, handle with TIR

Materials

Contact parts: 316 stainless steel

Main seal: PTFE

Alternatives are available, refer to the Design Options page

Design Conditions

Weight:	5.9 Kg
Design Pressure (MAWP):	6.9 Bar
Test Pressure:	12.6 Bar
Design Temperature Min:	-40°C
Design Temperature Max:	190°C

NOTE: The Design Conditions and Section View dimensions are for the specified part number only.

Design Code

BS EN14432

Range

Description	Part No.
Standard specification	535/3000
With gauze filter	535/3000F
With sintered filter	535/3000S
With TIR wire to 1/4" BSP plug	535/3000W

Related Parts

Description	Part No.
Blind flange	370/4239CM
Inlet gasket	5005-360
Pressure gauge	920/07BBSP
Gauge adaptor	352/4004
Stud kit	311/3700
Outlet gasket	5005-361
Weld-in flange	355/3100

Section View

GAUZE FILTER WITH SNAP RING & SPACER (SUFFIX F)

SINTERED FILTERS WITH SNAP RING & SPACER (SUFFIX S)

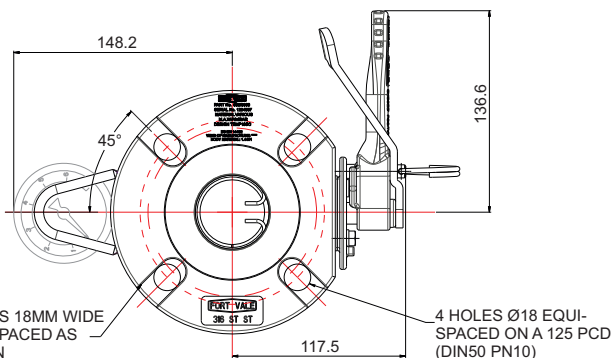
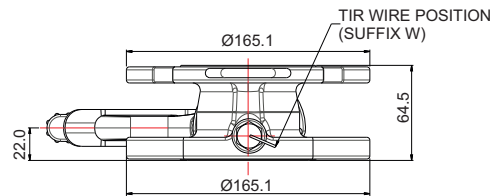
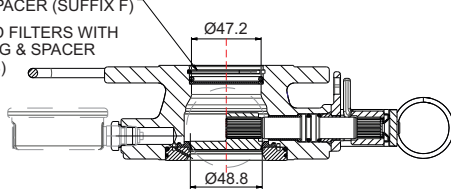

Parts Drawing

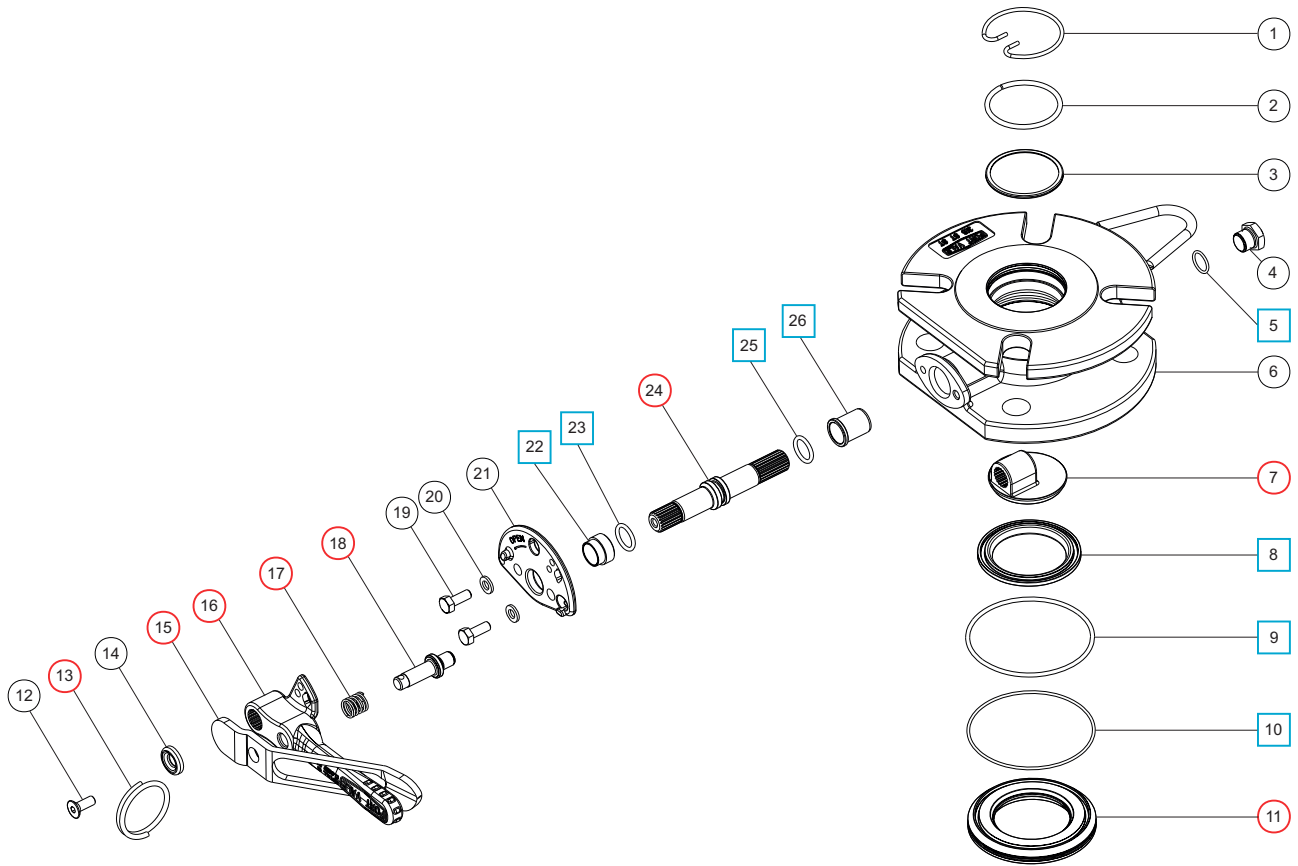

Parts List

Item	Description	Part No.
1	Snap ring *Note 1 & 2	5120-005
2	Spacer *Note 1 & 2	355/0295
3	Gauze filter *Note 1	355/0010
	Sintered filter (2) *Note 2	355/0206
4	1/4" BSP plug	5128-005
5	PTFE O ring	5005-048 <input type="checkbox"/> <input type="radio"/>
6	Body	535/3015
7	Closure plate	535/0225 <input type="radio"/>
8	Main seal	355/0202 <input type="checkbox"/> <input type="radio"/>
9	PTFE O ring	5005-659 <input type="checkbox"/> <input type="radio"/>
10	EPDM O ring	5005-664 <input type="checkbox"/> <input type="radio"/>
11	Seal plate	535/0201 <input type="radio"/>
12	M6 screw	5111-030
13	Split ring	368/0011 <input type="radio"/>
14	Retaining washer	20370
15	Operating lever	368/9838 <input type="radio"/>
16	Handle	535/0050 <input type="radio"/>
17	Handle spring	368/0012 <input type="radio"/>
18	Location pin	368/0010 <input type="radio"/>
19	M6 hex bolt (2)	5111-022

Parts List

Item	Description	Part No.
20	M6 spring washer (2)	5113-008
21	Stuffing clamp	535/0204C
22	Stuffing bush	368/0301 <input type="checkbox"/> <input type="radio"/>
23	PTFE O ring	20363 <input type="checkbox"/> <input type="radio"/>
24	Spindle	535/0203 <input type="radio"/>
25	Viton O ring	20361 <input type="checkbox"/> <input type="radio"/>
26	PTFE bearing	535/0009 <input type="checkbox"/> <input type="radio"/>

NOTE 1: Optional part, see Range 535/3000F

NOTE 2: Optional part, see Range 535/3000S

Seal Kit

Description	Part No.
All parts marked <input type="checkbox"/> in the Parts List	535/00SK

Repair Kit

Description	Part No.
All parts marked <input type="radio"/> in the Parts List	535/00RK