

Specification

Nominal size

50mm

Tank connection

Flanged: 4 x 18mm holes on a 125mm PCD

Outlet/Process connection

Flanged: 4 x 18mm open slots on a 120.7mm min. PCD compatible with 2" ASA150/DIN50 PN40

Properties

Kinetrol pneumatic actuator with spring return and ¼" BSP air inlet

Materials

Contact parts: 316 stainless steel

Main seal: PTFE

Alternatives are available, refer to the Design Options page

Design Conditions

Weight:	5.81 Kg
Design Pressure (MAWP):	7.5 Bar
Test Pressure:	13.8 Bar
Design Temperature Min.	Valve: -40°C
Design Temperature Min.	Actuator: -20°C
Design Temperature Max:	Valve: 205°C
Design Temperature Max:	Actuator: 80°C

NOTE: The Design Conditions and Section View dimensions are for the specified part number only.

Design Code

BS EN14432

Range

Description	Part No.
2" ball valve pneumatically actuated	370/0100PN/1
2" ball valve manually operated	370/0100

Related Parts

Description	Part No.
Mating flange	294/0082
Weld-in flange	355/3100
Stud kit	311/3700
Outlet gasket	5005-361
Blind flange	370/4239CM

Section View

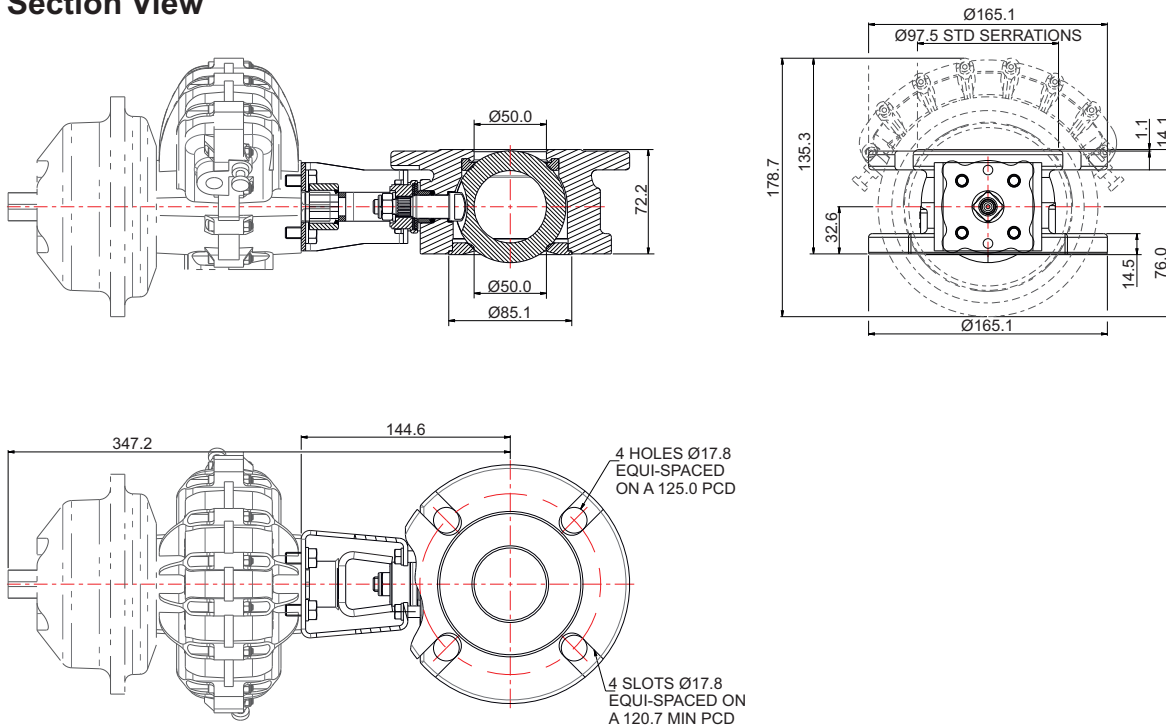

Parts Drawing

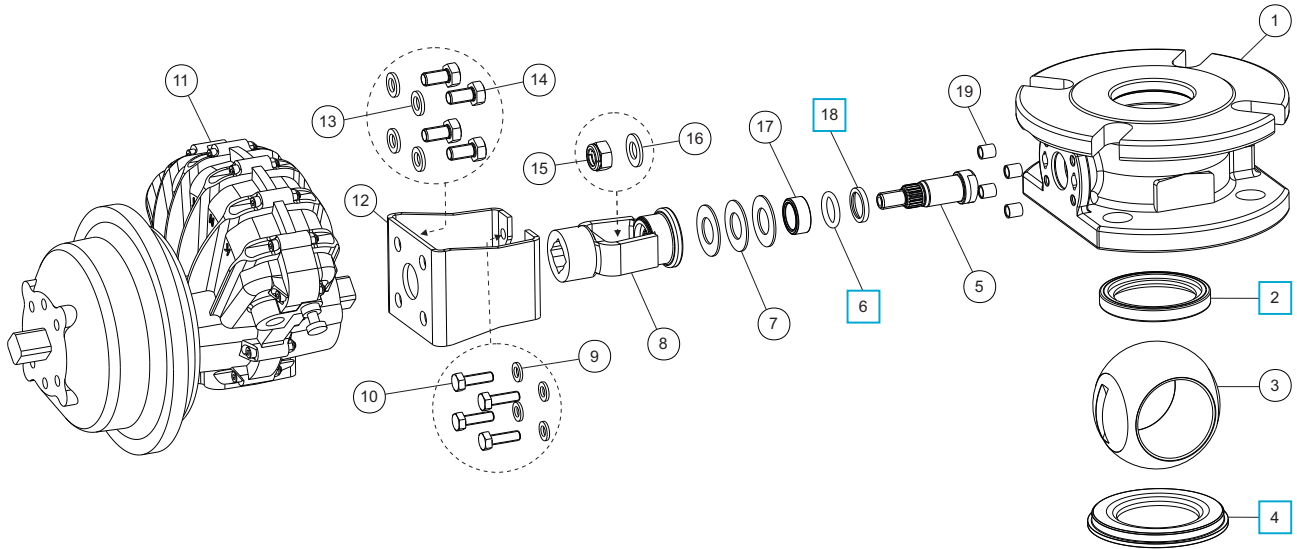

Parts List

Item	Description	Part No.
1	Body	370/0110
2	PTFE front seal	370/0102 <input type="checkbox"/>
3	Ø50mm ball	370/3301
4	PTFE rear seal	370/0105 <input type="checkbox"/>
5	Spindle	370/0120
6	PTFE O ring	5005-688 <input type="checkbox"/>
7	Belleville washer (3)	5113-038
8	Spline adaptor assembly	370/0209
9	M6 spring washer (4)	5113-008
10	M6 hex bolt (4)	5111-076
11	Kinetrol pneumatic actuator	5127-078
12	Mounting bracket	370/0208
13	M8 spring washer (4)	5113-003
14	M8 hex bolt (4)	5111-822
15	M10 self lock nut	5112-008
16	M10 plain washer	5113-009
17	Stuffing collar	370/0103
18	Bottom bearing bush	370/0104 <input type="checkbox"/>
19	Spacer boss (4)	370/0163

Seal Kit

Description	Part No.
All parts marked <input type="checkbox"/> in the Parts List	370/01SK