



Specification

Nominal size

32mm

Tank connection

Flanged: 4 x 10.8mm holes on a 103.5mm PCD

Outlet/Process connection

Threaded: 1½” BSP male

Properties

¼” BSP gauge connection, handle with TIR

Materials

Contact parts: 316 stainless steel

Main seal: PTFE

Alternatives are available, refer to the Design Options page

Design Conditions

Weight:	2.9 Kg
Design Pressure (MAWP):	10 Bar
Test Pressure:	21.4 Bar
Design Temperature Min:	-55°C
Design Temperature Max:	205°C

NOTE: The Design Conditions and Section View dimensions are for the specified part number only.

Design Code

BS EN14432

Range

Description	Part No.
Standard specification	530/0000
With gauze	530/0000F
With gauge guard	530/0000G
With gauze and gauge guard	530/0000FG
With TIR wire to ¼” BSP plug	530/0000W

Related Parts

Description	Part No.
Pressure gauge	920/07BBSP
Gauge adaptor	352/4004
1½” BSP dust cap	10300PS
Stud kit	350/1300
Weld-in flange	350/0025

Section View

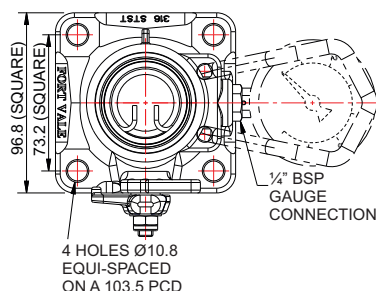
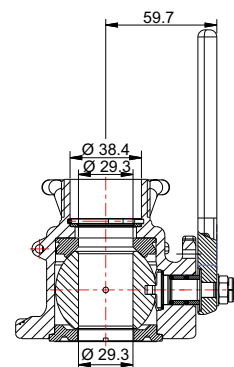
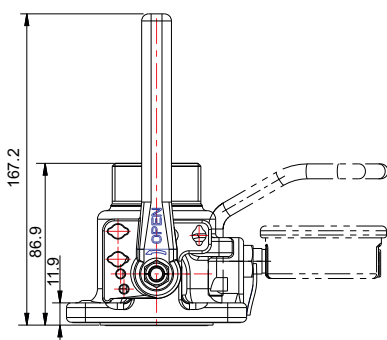

Parts Drawing

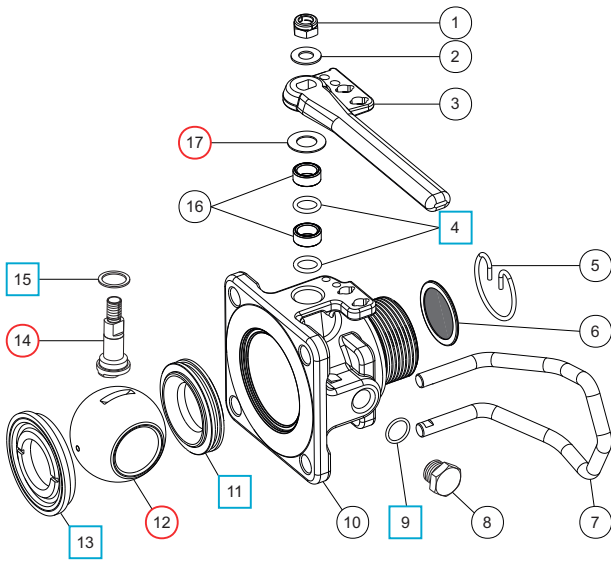

Parts List

Item	Description	Part No.
1	Self-locking nut	5112-031
2	M8 washer	5113-005
3	Handle	531/0025
4	PTFE O ring (2)	5005-008 <input type="checkbox"/> <input type="radio"/>
5	Snap ring * Note 1	5120-017
6	Gauze filter * Note 1	353/0010
7	Gauge guard * Note 2	530/0040
8	¼” BSP plug	5128-005
9	PTFE O ring	5005-048 <input type="checkbox"/> <input type="radio"/>
10	Body	530/0100
11	Front ball seal	5005-006 <input type="checkbox"/> <input type="radio"/>
12	Ball	350/0002 <input type="radio"/>
13	Rear ball seal	5005-007 <input type="checkbox"/> <input type="radio"/>
14	Spindle	530/0001 <input type="radio"/>
15	PTFE washer	5003-002 <input type="checkbox"/> <input type="radio"/>
16	Stuffing boss (2)	530/0003
17	Disc spring	5113-036 <input type="radio"/>

NOTE 1: Optional part, see Range 530/0000F

NOTE 2: Optional part, see Range 530/0000G

Seal Kit

Description	Part No.
All parts marked <input type="checkbox"/> in the Parts List	530/00SK

Repair Kit

Description	Part No.
All parts marked <input type="radio"/> in the Parts List	530/00RK