



## Catalogue

# Standard Equipment for Tank Containers







# CONTENTS

## Standard Equipment for Tank Containers

### Catalogue

<b>Manlid &amp; Inspection Hatch Assemblies</b>	<b>5</b>
Design Options: Manlid & Inspection Hatch Assemblies	7
300mm Ultra Low Profile Inspection Hatch Assembly	9
500mm Ultra Low Profile Pendle Manlid Assembly	11
<b>Relief Valves</b>	<b>13</b>
Design Options: Super Maxi & Hyper Maxi Relief Valves	15
2½" BSP Super Maxi Relief Valve - Pressure/Vacuum	17
82.5mm Flanged Hyper Maxi Relief Valve - Pressure/Vacuum	19
Installation Options: Super Maxi & Hyper Maxi Relief Valves	21
<b>Airline Valves</b>	<b>23</b>
Design Options: Airline Ball Valves & Butterfly Valves	25
1½" BSP Blacko Ball Valve	27
2" BSP Airline Butterfly Valve	29
2" MKII Flanged Airline Butterfly Valve	31
Installation Options: Airline Ball Valves & Butterfly Valves	33
<b>Bottom Discharge Valves</b>	<b>35</b>
Design Options: Footvalves	37
3" 45° Cleanflow Footvalve	39

Continued over



# CONTENTS

## Standard Equipment for Tank Containers

### Catalogue

3" 45° MKIII Highlift Footvalve	41
3" 45° Uniflow Bottom Discharge Assembly	43
3" 45° Univalve Bottom Discharge Assembly	47
Design Options: Discharge Butterfly Valves	51
3" Clamped Widdop Butterfly Valve	53
3" Clamped Widdop Butterfly Valve - High Temperature	55
Installation Options: Bottom Discharge Assembly	57
Design Options: Discharge Ball Valves	59
DN40 Ball Valve with Inlet Seal Clamp	61
DN50 Ball Valve with Inlet Seal Clamp	65
DN80 Ball Valve with Inlet Seal Clamp	69
<b>Top Discharge Provision</b>	<b>73</b>
3" Flanged Widdop Butterfly Valve	75
3" Flanged Widdop Butterfly Valve - Dual Drilled Inlet	77
Installation Options: Butterfly Valve Top Discharge Assembly	79
<b>Accessories</b>	<b>81</b>
3/4" BSPT Steam Tell-Tale Valve	83
3/4" BSPT Steam Relief Valve	85

Continued over



---

# CONTENTS

## Standard Equipment for Tank Containers

### Catalogue

---

Blank Caps	87
Burst Discs	88
Document Holders	90
Fusible Link Assembly	91
Relief Valve Flame Arresters	92
Pressure Gauges	93
Temperature Gauges	94
<b>After Sales Service</b>	<b>95</b>
Valve Repair & Maintenance	97
Bolt Torque Guide & Step Loading Procedure	99
Client Responsibilities	101
Fort Vale Worldwide	103





---

# Manlid & Inspection Hatch Assemblies









# Manlid & Inspection Hatch Assemblies

## Design Options

### Function

A manlid assembly or inspection hatch assembly is usually installed on the top of the tank. A manlid assembly is used to give access to personnel to let them examine, repair or clean the inside of the tank. An inspection hatch is used for access to take a sample of cargo and can also be used as access for cleaning equipment.

### Design Options

The design options below are available on our standard range of hinged circular manlid and inspection hatch assemblies. We can deliver manlids and inspection hatches assembled or disassembled.

#### Nominal Diameter

**Inspection Hatch:**  
170mm, 300mm

**Manlid:**  
460mm, 500mm, 600mm



#### Design Pressure: MAWP

From 0 Bar to 4 Bar

**Special service conditions:**  
> 4 Bar

#### Opening Angle

120°: Fixed or liftover

135°: Fixed or liftover



#### Fixing Points

3, 4, 6, 8 points

**Special service conditions:**  
Single point, 10 points

#### Neckring / Compensating Ring

**Height:** From ultra-low to extended

**Profile:** Straight (no profile) or profiled compatible with the tank radius

**Compensation:** With or without compensating ring

**Material thickness:** 6mm, 8mm or compatible with the MAWP and the tank shell thickness



#### Swingbolt Assemblies

**Eyebolt:** stainless steel

**Handnut:** naval brass - low profile; stainless steel - low profile or extended, with/without brass insert

**Special service conditions:**  
Safebolt assembly (at one point)

Hexagonal nuts

Bow nuts

Single arm handnuts

Quick release latches

With locknuts

#### Material

Contact parts: 316 stainless steel

**Special service conditions:**  
304 stainless steel

High nickel alloys

Carbon steel: Neckring only

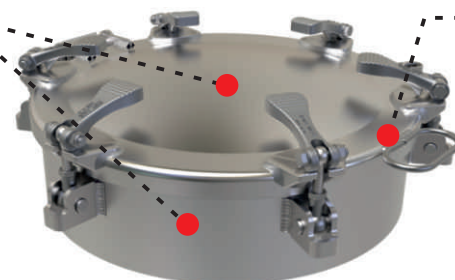

#### Seal

A large range of seal materials is available



## Manlid & Inspection Hatch Assemblies Design Options

### Design Options - continued

#### Special Options

Where compatible, we can also offer:

Weld-in fittings: E.g. sockets, flanges, breathers, vents, sight glass

Customer logo: Laser etched on cover

Hand polishing: To ultra-high grade

Lining: For corrosive cargo



### Related Parts

We recommend our range of compatible accessories:

- Manlid cover seals
- Safebolts
- Fasteners

We have a large range of accessories, please contact us for more information about these parts.

### Manlid Assemblies for Dedicated Service

We offer a range of manlid assemblies for these service conditions and special cargoes:

- Elliptical manlid assemblies for brewery & hygienic service
- Flat bolted assemblies for high pressure/dangerous cargo
- U.S. tank trucks
- Rail tank cars
- Hydrogen peroxide service
- Side-entry manlid assemblies for hygienic service

Please contact us for more information about these special assemblies.



# 300mm Ultra Low Profile Inspection Hatch Assembly

Part No: 8PB/2750XXXP



## Specification

### Nominal size

DN300

### Cover

4 point

### Neckring/compensating ring

Thickness: 8mm

Tank radius profiling range: 750mm to 1220mm

### Materials

Contact parts: 316 stainless steel

Fasteners: stainless steel swingbolts with naval brass handnuts

Seal: supplied separately

Alternatives are available, refer to the Design Options page

## Design Conditions

Weight:	19.8 Kg
Design Pressure (MAWP):	4 Bar
Test Pressure:	6 Bar
Design Temperature Min:	-40°C
Design Temperature Max:	200°C

**NOTE:** The Design Temperature limits refer to metal parts only. The Design Conditions and Section View dimensions are for the specified part number only.

### Design Code

BS EN 14025: 730/0600P cover only

## Range

Handnut Material	Part No.
Naval brass	8PB/2750XXXP
Stainless steel	8PB/2750XXXS

**NOTE:** The assembly specification changes the Part No.

## Section View

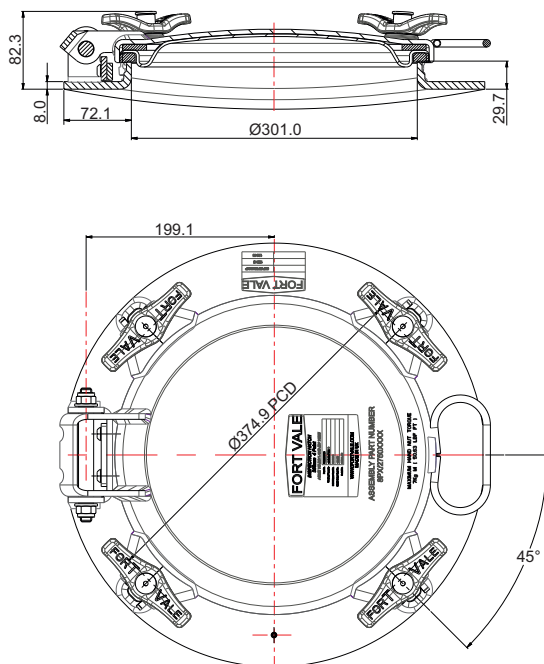



# 300mm Ultra Low Profile Inspection Hatch Assembly

Part No: 8PB/2750XXXP

## Parts Drawing

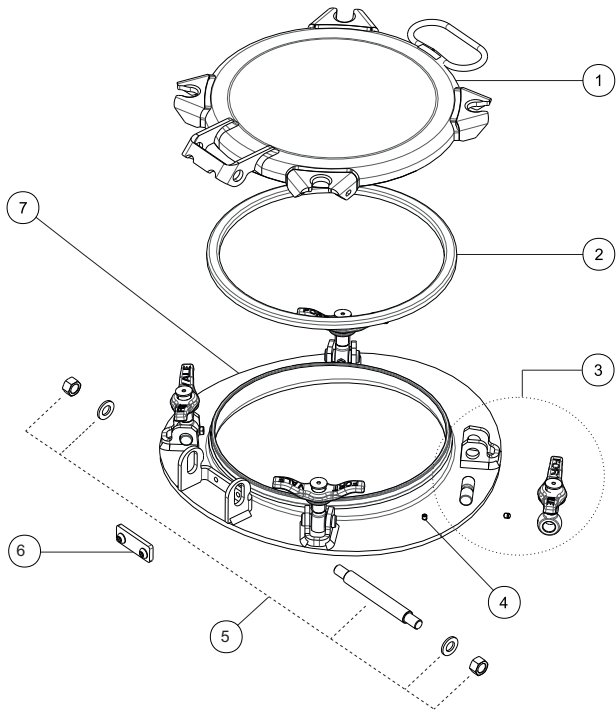

## Parts List

Item	Description	Part No.
1	Cover	703/0600P
2	Seal (not included) <b>*Note</b>	5005-XXXX
3	Swingbolt assembly (4)	496/1260
4	Grubscrew	5111-009
5	Hinge pin assembly	600/1060
6	Hinge kit - 135° fixed	135B
7	Neck/compensating ring <b>*Note</b>	63P/2750XXXP

**NOTE:** The specification changes the Part No.



# 500mm Ultra Low Profile Pendle Manlid Assembly

Part No: E4C/85XX025B



## Specification

### Nominal size

DN500

### Cover

8 point

### Neckring/compensating ring

Thickness: 8mm

Tank radius profiling range: 750mm to 1300mm

### Materials

Contact parts: 316 stainless steel

Fasteners: stainless steel swingbolts with naval brass handnuts

Seal: supplied separately

Alternatives are available, refer to the Design Options page

## Design Conditions

Weight:	40 Kg
Design Pressure (MAWP):	4 Bar
Test Pressure:	6 Bar
Design Temperature Min:	-40°C
Design Temperature Max:	200°C

**NOTE:** The Design Temperature limits refer to metal parts only. The Design Conditions and Section View dimensions are for the specified part number only.

### Design Codes

BS EN14025: 74E/0500 cover only (4 Bar)

BS EN14025: 73E/0500 cover only (3 Bar)

## Range

Points	MAWP	Part No.
8	4 Bar	E4C/85XX025B
6	3 Bar	E3C/65XX025B

**NOTE:** The assembly specification changes the Part No.

## Section View

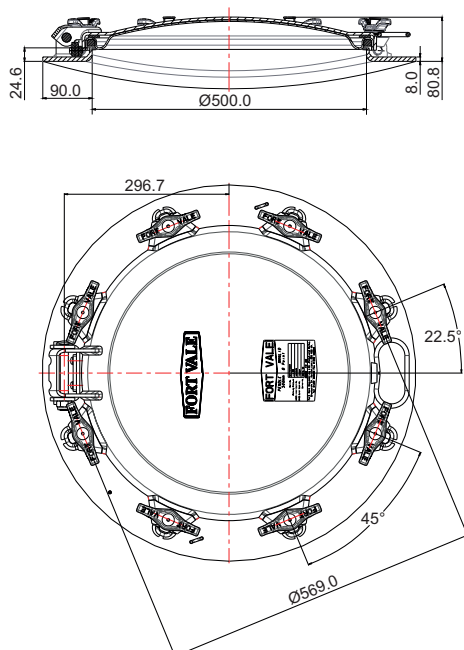



# 500mm Ultra Low Profile Pendle Manlid Assembly

Part No: E4C/85XX025B

## Parts Drawing

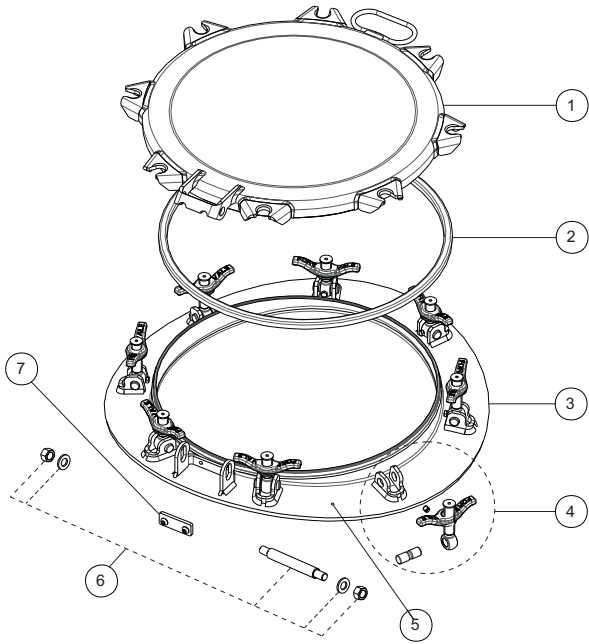

## Parts List

Item	Description	Part No.
1	Cover	74E/0500
2	Seal (not included) * <b>Note</b>	5005-XXXX
3	Neck/compensating ring * <b>Note</b>	6EP/7403XXXP
4	Long swingbolt assy. (4) * <b>Note</b>	496/XXXX
	Short swingbolt assembly (4)	496/1240
5	Grub screw	5111-009
6	Hinge pin assembly	600/1060
7	Hinge kit - 135° fixed	135B

**NOTE:** The specification changes the Part No.



# Relief Valves









# Super Maxi & Hyper Maxi Relief Valves

## Design Options

### Function

A Super Maxi or Hyper Maxi is a spring-loaded relief valve which is installed in the vapour space of a tank. It is pre-set to be compatible with the service conditions and it vents to protect the tank from accidental over-pressure or unwanted vacuum conditions.

Super Maxi & Hyper Maxi relief valves have a high flow performance to prevent the catastrophic failure of a tank. This type of valve is often used on tanks carrying hazardous cargo.

We offer a range of relief valves for different service conditions and flow requirements. Contact us for more information.

### Design Options

The design options below are available on our standard range of Super Maxi & Hyper Maxi relief valves.

#### Tank Connection

2½" BSP

Flanged with holes or slots: a selection of drilling patterns is available

**Special service conditions:**  
DIN11851: 80mm



#### Special Options

Manual vacuum vent button

#### Tank Seal

Rubber/PTFE - 2½" BSP only  
Other materials are available

#### Nominal Bore

65mm: Super Maxi

82.5mm: Hyper Maxi

**Special service conditions:**  
Tapered bore: 65mm to 80mm



#### Body

Standard body:  
Super Maxi: ≤ 4.8 Bar  
Hyper Maxi: ≤ 5.15 Bar

Extended body:  
Super Maxi: ≥ 4.55 Bar  
Hyper Maxi: ≥ 5.15 Bar

#### Pressure Setting

Super Maxi: 0.15 Bar to 16 Bar  
Hyper Maxi: 0.15 Bar to 14.3 Bar

#### Pressure Seal

Fortyt

**Special service conditions:**  
A range of seal materials is available

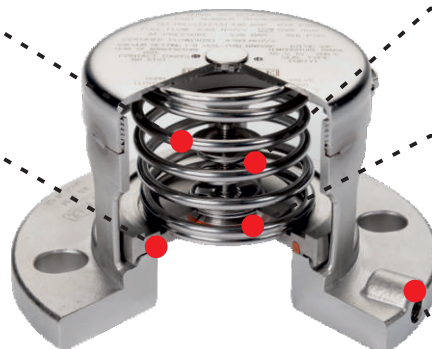

#### Vacuum Setting

From 2 kPa to 88 kPa

#### Vacuum Seal

Fortyt

**Special service conditions:**  
A range of seal materials is available

#### Gauge Connection

**Flanged valves only:**  
¼" BSP (standard)  
¼" NPT (special)



## Super Maxi & Hyper Maxi Relief Valves

### Design Options

### Design Options - continued

#### Valve Materials

316 stainless steel

#### Special service conditions:

Lined/coated wetted parts e.g. PFA

High nickel alloys



#### Finish

Electropolished

#### Special service conditions:

Corrosion-resistant paint on external surfaces to prevent damage from corrosive cargo vapour/splash

### Related Parts

We recommend our range of compatible accessories:

- Flame arrester or gauzed cowl **\*Note**
- Burst discs **\*Note**
- Pressure gauges
- Flanges - weld-in and adaptor
- Weld-in sockets
- Gaskets
- Fasteners

**NOTE:** If you install an accessory item, e.g. a flame arrester, cowl, burst disc or baffle, it will decrease the air flow capacity of the relief valve. Thus, you must calculate again to make sure that the decreased flow capacity will give sufficient protection to your vessel/system.

Please contact us for more information about these parts.

### Relief Valves for Dedicated Service

We offer a range of relief valves for these service conditions and special cargoes:

- T50 tank containers for liquefied gas
- Rail tank wagons
- U.S. tank trucks
- IBCs and small capacity tanks
- Steam-heating systems for tanks
- Hygienic service
- Food grade for liquid flow

Please contact us for more information about these valves.



# 2 1/2" BSP Super Maxi Relief Valve - Pressure/Vacuum

Part No: 010/1XXXXX - Metric Setting



## Specification

**Nominal size**  
DN65

**Tank connection**  
2 1/2" BSP

**Set pressure**  
From 0.15 Bar to 5.15 Bar

**Set vacuum**  
From 1 kPa to 88 kPa

**Materials**  
Contact parts: 316 stainless steel  
Pressure O ring: Fortyt  
Vacuum O ring: Fortyt  
Tank seal: Rubber/PTFE envelope

Alternatives are available, refer to the Design Options page

## Design Conditions

Weight: 2.9 Kg  
Design Pressure (MAWP): 5.2 Bar  
Test Pressure: 10.1 Bar  
Design Temperature Min: -55°C  
Design Temperature Max: 200°C

**NOTE:** The working temperature of the pressure and vacuum O rings can change the design temperature limits. The Design Conditions and Section View dimensions are for the specified part number only.

### Approval

Design Approval by Lloyds Register of Shipping

**WARNING:** If you install an approved relief valve accessory item, e.g. a flame arrester, cowl, burst disc or baffle, it will decrease the air flow capacity of the relief valve. Thus, you must calculate again to make sure that the decreased air flow capacity will give sufficient protection to your vessel/system. Refer to Fort Vale for more information.

## Range

Standard Settings	Part No.
2.19 Bar & 21 kPa	010/121921
3.31 Bar & 21 kPa	010/133121
3.71 Bar & 21 kPa	010/137121
4.40 Bar & 21 kPa	010/144021

## Related Parts

Description	Part No.
2 1/2" BSP weld-in socket	600/1000
Tank weld-in flange	176/3150
CNAF/PTFE gasket (adaptor flange)	5005-398
0-7 Bar pressure gauge, brass internal parts	921/07BBSP
0-7 Bar pressure gauge, stainless steel internal parts	920/07BBSP
Flame arrester <b>*Warning</b>	176/2900
Gauzed cowl <b>*Warning</b>	176/6000

## Section View

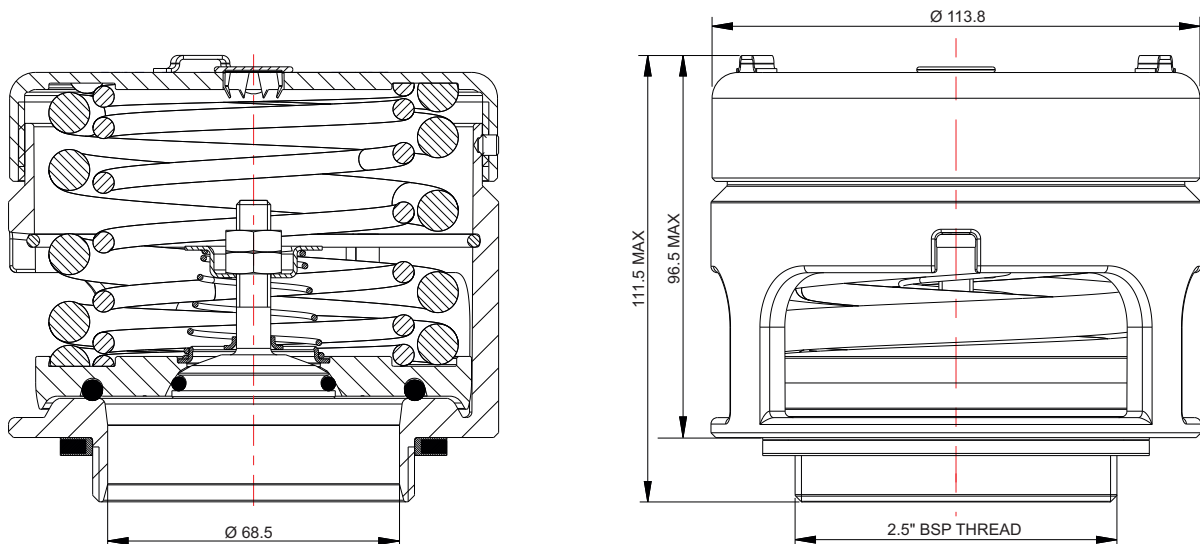



# 2 1/2" BSP Super Maxi Relief Valve - Pressure/Vacuum

Part No: 010/1XXXXX - Metric Setting

## Parts Drawing

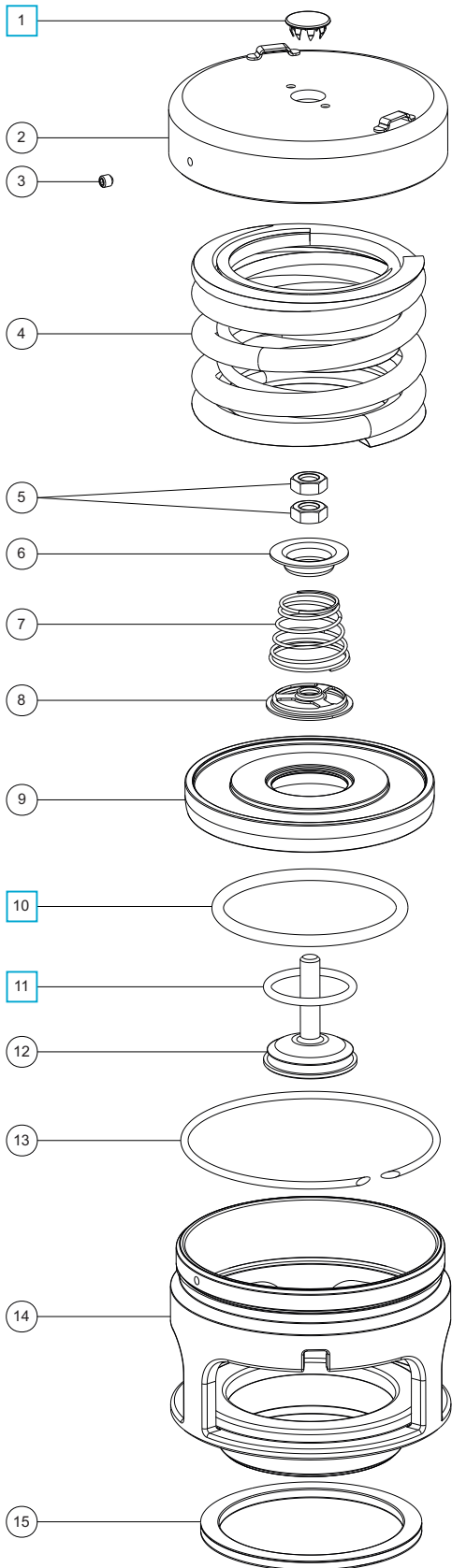

## Parts List

Item	Description	Part No.	
1	Stainless steel plug	10978	<input type="checkbox"/>
2	Cap *Note	1760/0005XX	
3	Anti-tamper screw	5121-001	
4	Pressure springs	Refer to Table 1	
5	M8 half nut (2)	5112-004	
6	Vacuum spring pad	1860/0005	
7	Vacuum spring	Refer to Table 2	
8	Spring pad	10986/3	
9	Pressure plate *Note	1860/005XXX	
10	Fortyt pressure O ring	5005-101	<input type="checkbox"/>
11	Fortyt vacuum O ring	5005-108H	<input type="checkbox"/>
12	Vacuum poppet	10983V/3	
13	Retaining ring clip	5120-067	
14	Body	1860/0100	
15	Rubber/PTFE envelope seal	5005-046	

**NOTE:** The valve specification changes the Part No.

## Table 1

Std. Pressure Settings	Pressure Spring Part No.
2.19 Bar	6104-0252
3.31 Bar	6104-0112 & 6104-0252
3.71 Bar	6104-0422 (Pair)
4.40 Bar	6104-0485 (Pair)

Pressure springs are available from 0.15 Bar to 5.15 Bar

## Table 2

Std. Vacuum Setting	Vacuum Spring Part No.
21 kPa	7104-012

Vacuum springs are available from 1 kPa to 88 kPa

## Seal Kit

Description	Part No.
All parts marked <input type="checkbox"/> in the Parts List	000/1PVSK



# 82.5mm Flanged Hyper Maxi Relief Valve - Pressure/Vacuum

Part No: 043/1XXXXX82S - Metric Settings



## Specification

**Nominal size**  
DN80

**Tank connection**

Flanged: 4 slots equi-spaced on a 145.0/152.4 min/max PCD. 1/4" BSP gauge connection.

Refer to Flange Drilling & Accessory Parts

**Set pressure**

From 0.15 Bar to 5.15 Bar

**Set vacuum**

From 1 kPa to 88 kPa

**Materials**

Contact parts: 316 stainless steel

Pressure O ring: Fortyt

Vacuum O ring: Fortyt

Alternatives are available, refer to the Design Options page

## Design Conditions

Weight:	5.85 Kg
Design Pressure (MAWP):	5.2 Bar
Test Pressure:	10.2 Bar
Design Temperature Min:	-55°C
Design Temperature Max:	200°C

**NOTE:** The working temperature of the pressure and vacuum O rings can change the design temperature limits. The Design Conditions and Section View dimensions are for the specified part number only.

**Approval**

Design Approval by Lloyds Register of Shipping for valves with a setting of  $\geq 1.7$  Bar

**WARNING:** If you install an approved relief valve accessory item, e.g. a flame arrester, cowl, burst disc or baffle, it will decrease the air flow capacity of the relief valve. Thus, you must calculate again to make sure that the decreased air flow capacity will give sufficient protection to your vessel/system. Please refer to Fort Vale for more information.

## Flange Drilling & Accessory Parts

Drilling Spec.	PCD mm	Weld-in flange	Gasket
DIN65 PN10	145.0	176/3250	5005-332
3" Table D	146.1	176/3140	5005-013
DIN80 PN6	150.0	176/3158	5005-334
3" ASA 150	152.4	176/3125	5005-204

## Related Parts

Description	Part No.
0-7 Bar pressure gauge, brass internal parts	921/07BBSP
0-7 Bar pressure gauge, stainless steel internal parts	920/07BBSP
Flame arrester <b>*Warning</b>	176/2920
M16 stud kit: 150 & 152.4 PCD	311/3700
M16 cap screw bolt kit: 145 & 146 PCD	311/3785

## Section View

Shown with a flame arrester installed

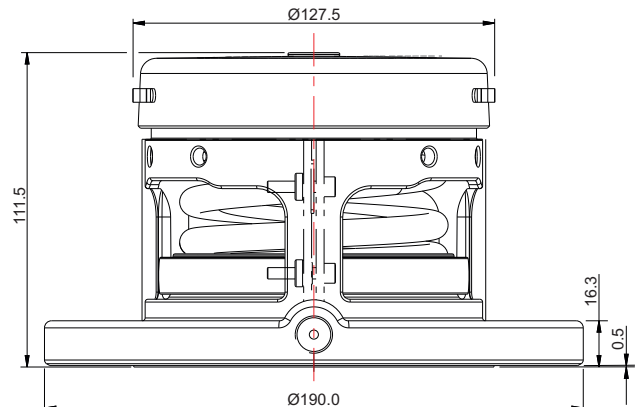
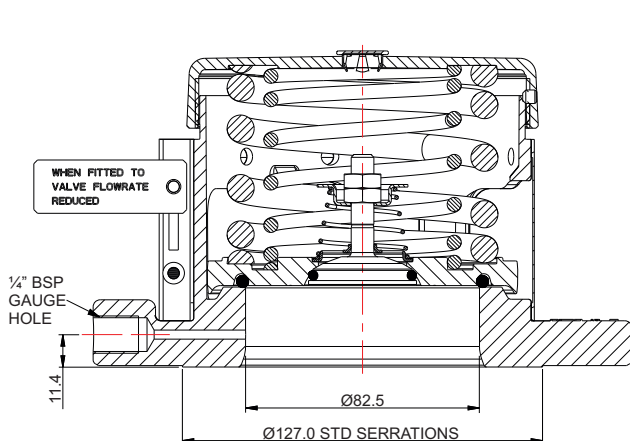



# 82.5mm Flanged Hyper Maxi Relief Valve - Pressure/Vacuum

Part No: 043/1XXXXX82S - Metric Settings

## Parts Drawing

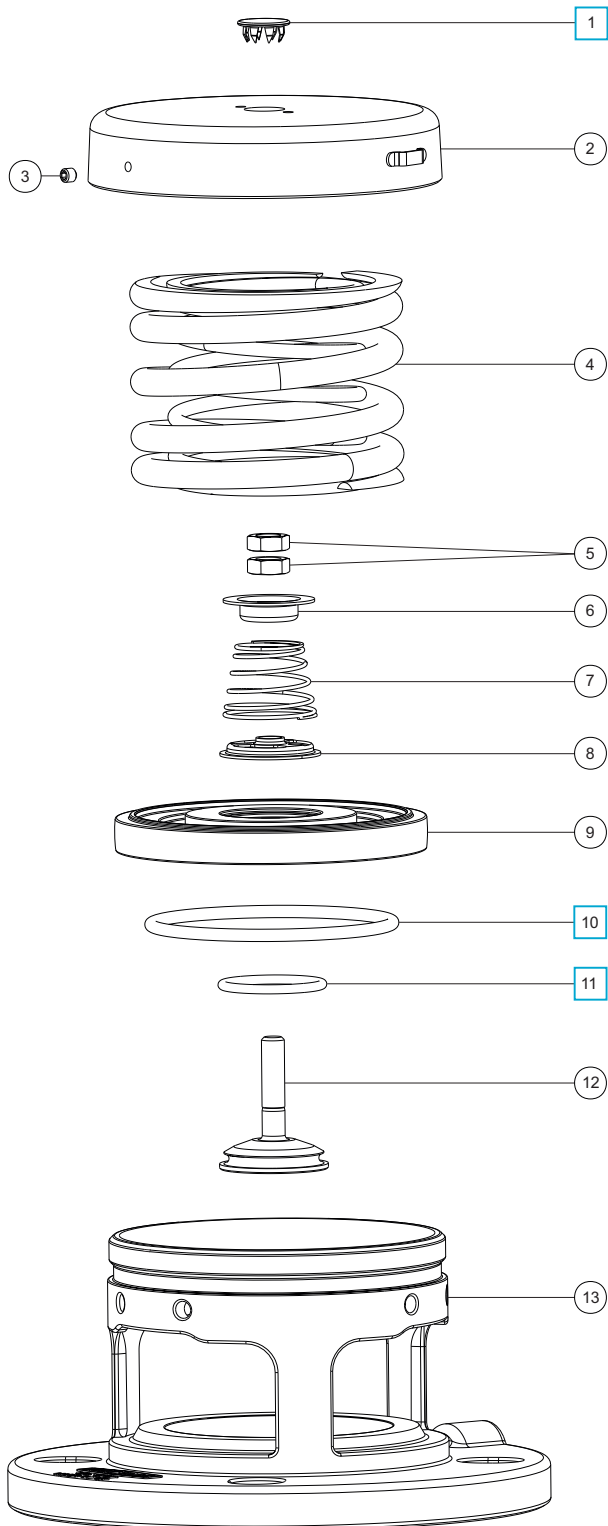

## Parts List

Item	Description	Part No.
1	Stainless steel plug	10978 <input type="checkbox"/>
2	Cap *Note	1860/1008XX
3	Anti-tamper screw	5121-001
4	Pressure spring	Refer to Table 1
5	M8 half nut (2)	5112-004
6	Vacuum spring pad	1860/0005
7	Vacuum spring	Refer to Table 2
8	Spring pad	10986/3
9	Pressure plate *Note	1860/1071XX
10	Fortyt pressure O ring	ORB337F0 <input type="checkbox"/>
11	Fortyt vacuum O ring	5005-108H <input type="checkbox"/>
12	Vacuum poppet	10983V/3
13	Body	1860/19SL

**NOTE:** The valve specification changes the Part No.

### Table 1

Std. Pressure Settings	Pressure Spring Part No.
2.20 Bar	6104-0048 & 6104-0310
2.65 Bar	6104-0085 & 6104-0310
3.30 Bar	6104-0195 & 6104-0310
4.40 Bar	6104-0665 (Pair)

Pressure springs are available from 0.15 Bar to 5.15 Bar

### Table 2

Std. Vacuum Setting	Vacuum Spring Part No.
21 kPa	7104-012

Vacuum springs are available from 1 kPa to 88 kPa

### Seal Kit

Description	Part No.
All parts marked <input type="checkbox"/> in the Parts List	043/1PVSK



## Super Maxi & Hyper Maxi Relief Valve Installation Options

### Flanged Super Maxi/Hyper Maxi relief valve with burst disc and tank weld-in flange

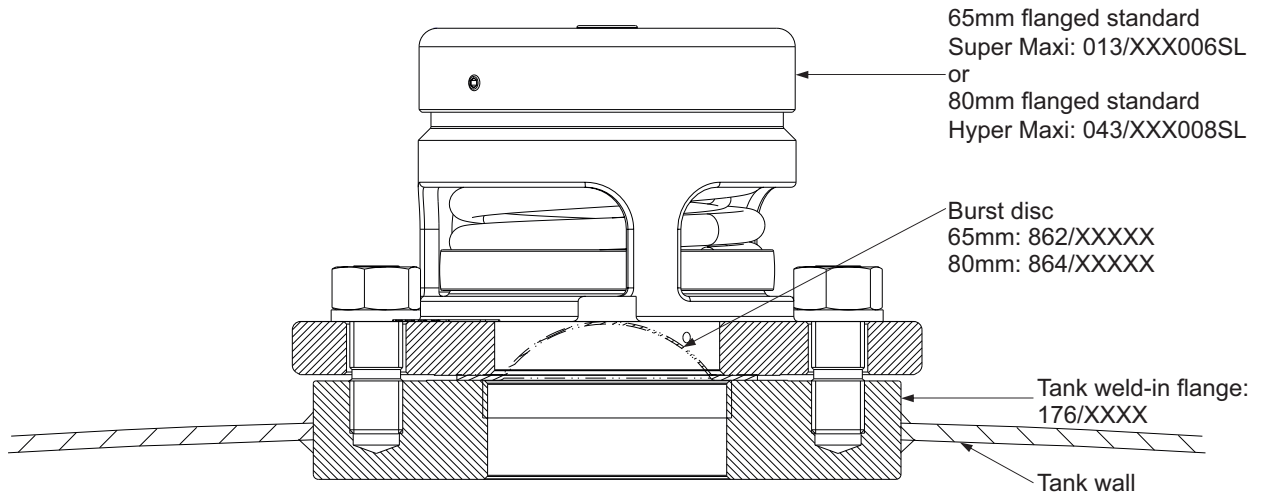

### 2½" BSP Super Maxi with weatherproof cowl and tank weld-in socket

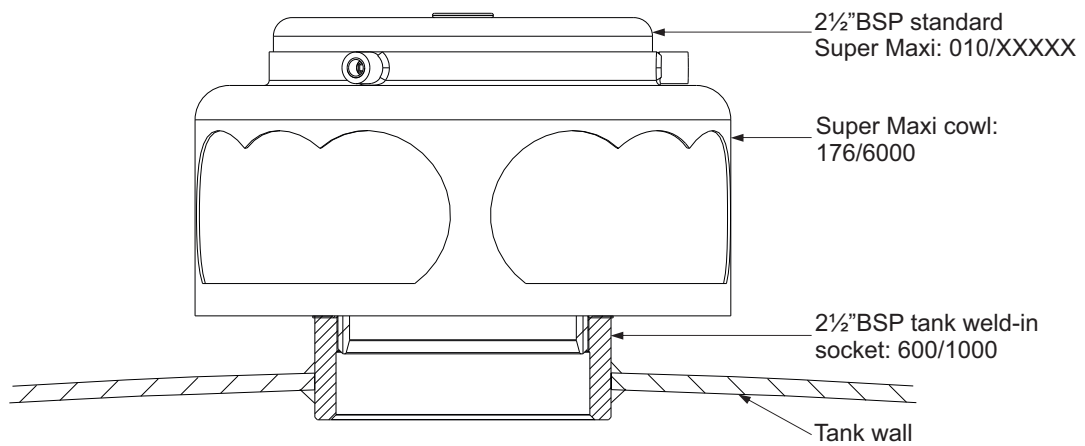

### 2½" BSP Super Maxi with burst disc, pressure gauge, adaptor flange & weld-in socket

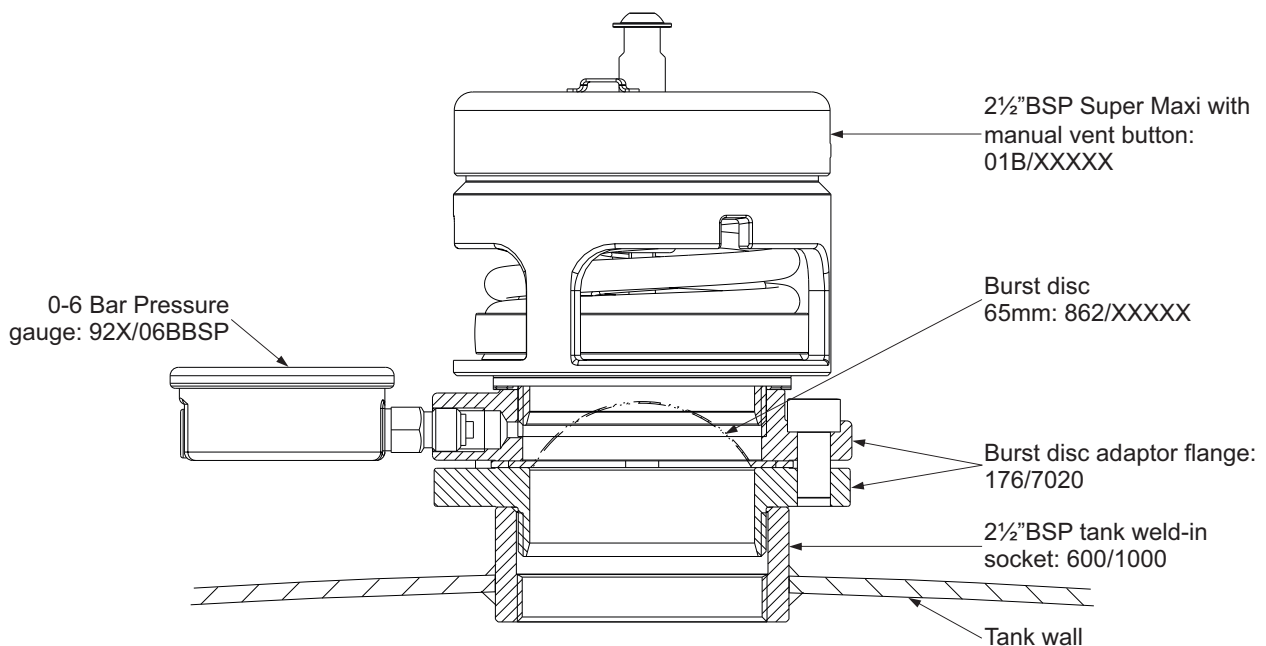







# Airline Valves

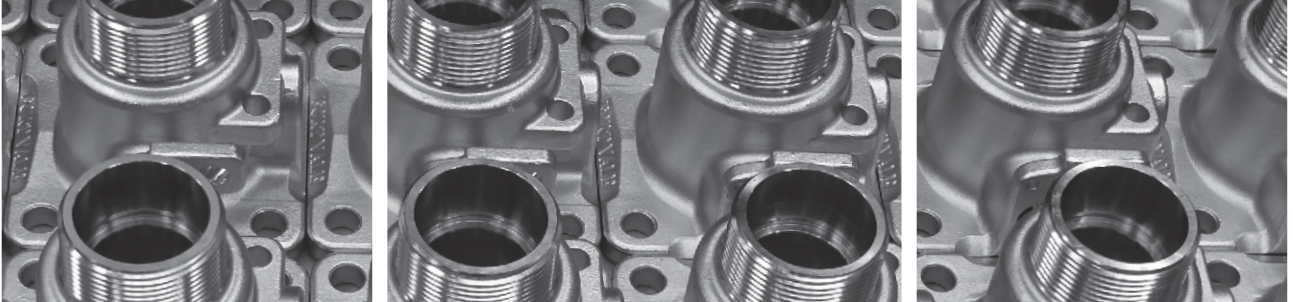





# Airline Ball Valves & Butterfly Valves

## Design Options

### Function

An airline valve is used when the tank is pressurised during testing or discharge and can be used for inert gas blanketing or vapour recovery. We offer ball valves and butterfly valves for airline connections.

### Design Options

The design options below are available on our standard range of airline valves.

#### Nominal Bore

40mm (1½"): Ball valves

50mm (2"): Ball valves & butterfly valves

#### Special service conditions:

Reduced bore e.g. 25mm (1")

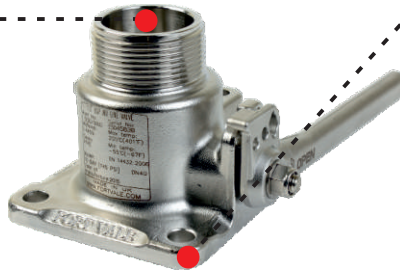

#### Tank Connection

Flanged: 4 holes

Different drilling patterns

#### Operation

Manually operated: A range of handles is available

Pneumatically actuated

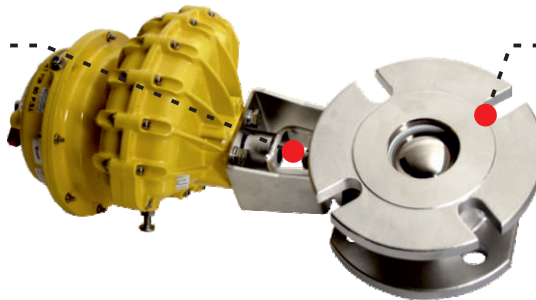

#### Outlet / Process Connection

Threaded: 1½" BSP, 2" BSP

Dual threaded: 1½" BSP/1½" NPT

Flanged: Closed or open slots

#### Valve Materials

316 stainless steel

#### Special service conditions:

Lined wetted parts, e.g. PFA

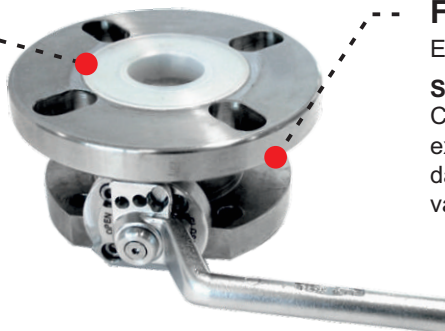

#### Finish

Electropolished

#### Special service conditions:

Corrosion-resistant paint on external surfaces to prevent damage from corrosive cargo vapour/splash

#### Accessories

Gauge guard

Gauze or sintered filter

TIR to gauge inlet plug

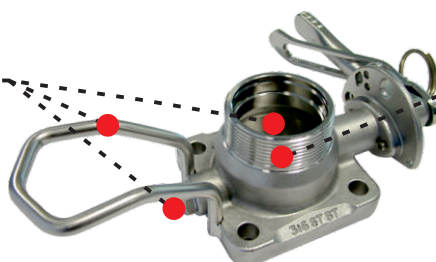

#### Main Seal

PTFE

#### Special service conditions:

High-temperature compatible seals



## Airline Ball Valves & Butterfly Valves

### Design Options

---

### Related Parts

We recommend our range of compatible accessories:

- Pressure gauges
- Filters: gauzed or sintered
- Blank caps
- Flanges - weld-in and adaptor
- Fasteners
- Gaskets

Please contact us for more information about these parts.



# 1½” BSP Blacko Airline Ball Valve

Part No: 530/0000

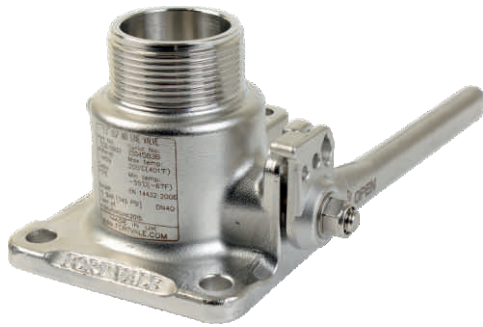

## Specification

### Nominal size

32mm

### Tank connection

Flanged: 4 x 10.8mm holes on a 103.5mm PCD

### Outlet/Process connection

Threaded: 1½” BSP male

### Properties

¼” BSP gauge connection, handle with TIR

### Materials

Contact parts: 316 stainless steel

Main seal: PTFE

Alternatives are available, refer to the Design Options page

## Design Conditions

Weight:	2.9 Kg
Design Pressure (MAWP):	10 Bar
Test Pressure:	21.4 Bar
Design Temperature Min:	-55°C
Design Temperature Max:	205°C

**NOTE:** The Design Conditions and Section View dimensions are for the specified part number only.

### Design Code

BS EN14432

## Range

Description	Part No.
Standard specification	530/0000
With gauze	530/0000F
With gauge guard	530/0000G
With gauze and gauge guard	530/0000FG
With TIR wire to ¼” BSP plug	530/0000W

## Related Parts

Description	Part No.
Pressure gauge	920/07BBSP
Gauge adaptor	352/4004
1½” BSP dust cap	10300PS
Stud kit	350/1300
Weld-in flange	350/0025

## Section View

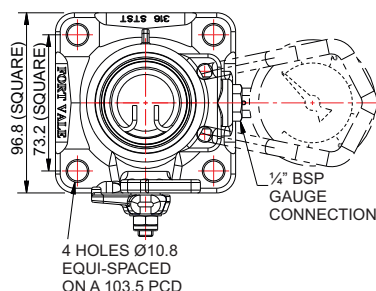
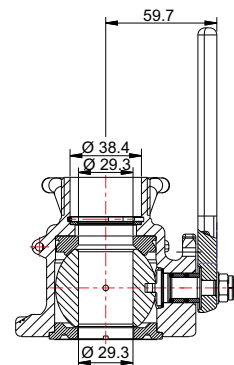
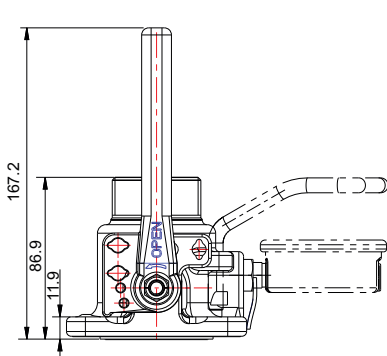



# 1½” BSP Blacko Airline Ball Valve

Part No: 530/0000

## Parts Drawing

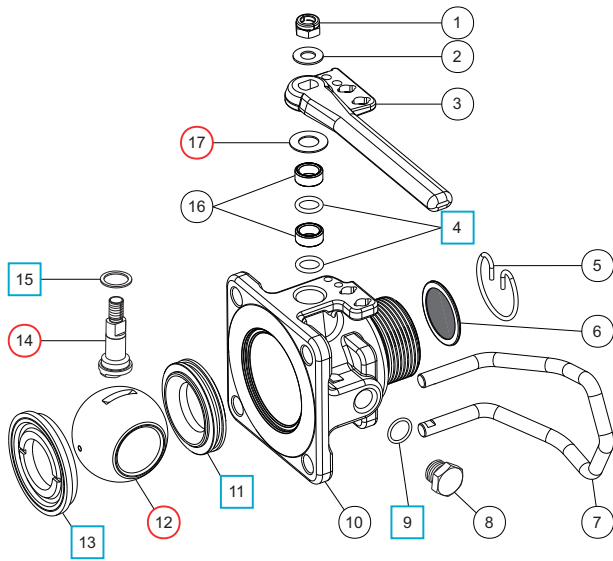

## Parts List

Item	Description	Part No.
1	Self-locking nut	5112-031
2	M8 washer	5113-005
3	Handle	531/0025
4	PTFE O ring (2)	5005-008 <input type="checkbox"/> <input type="radio"/>
5	Snap ring *Note 1	5120-017
6	Gauze filter *Note 1	353/0010
7	Gauge guard *Note 2	530/0040
8	¼” BSP plug	5128-005
9	PTFE O ring	5005-048 <input type="checkbox"/> <input type="radio"/>
10	Body	530/0100
11	Front ball seal	5005-006 <input type="checkbox"/> <input type="radio"/>
12	Ball	350/0002 <input type="radio"/>
13	Rear ball seal	5005-007 <input type="checkbox"/> <input type="radio"/>
14	Spindle	530/0001 <input type="radio"/>
15	PTFE washer	5003-002 <input type="checkbox"/> <input type="radio"/>
16	Stuffing boss (2)	530/0003
17	Disc spring	5113-036 <input type="radio"/>

**NOTE 1:** Optional part, see Range 530/0000F

**NOTE 2:** Optional part, see Range 530/0000G

## Seal Kit

Description	Part No.
All parts marked <input type="checkbox"/> in the Parts List	530/00SK

## Repair Kit

Description	Part No.
All parts marked <input type="radio"/> in the Parts List	530/00RK



# 2" BSP Airline Butterfly Valve

Part No: 535/0200



## Specification

### Nominal size

50mm

### Tank connection

Flanged: 4 x 10.9mm holes on a 100mm PCD

### Outlet/Process connection

Threaded: 2" BSP male

### Properties

1/4" BSP gauge connection, gauge guard, handle with TIR

### Materials

Contact parts: 316 stainless steel

Main seal: PTFE

Alternatives are available, refer to the Design Options page

## Design Conditions

Weight:	3.7 Kg
Design Pressure (MAWP):	6.9 Bar
Test Pressure:	12.5 Bar
Design Temperature Min:	-40°C
Design Temperature Max:	190°C

**NOTE:** The Design Conditions and Section View dimensions are for the specified part number only.

### Design Code

BS EN14432

## Range

Description	Part No.
Standard specification	535/0200
With gauze filter	535/0200F
With sintered filter	535/0200S

## Related Parts

Description	Part No.
Dust cap	10301PS
Pressure gauge	920/07BBSP
Gauge adaptor	352/4004
Stud kit	350/1300
Gasket	5005-500
Weld-in flange	355/1000

## Section View

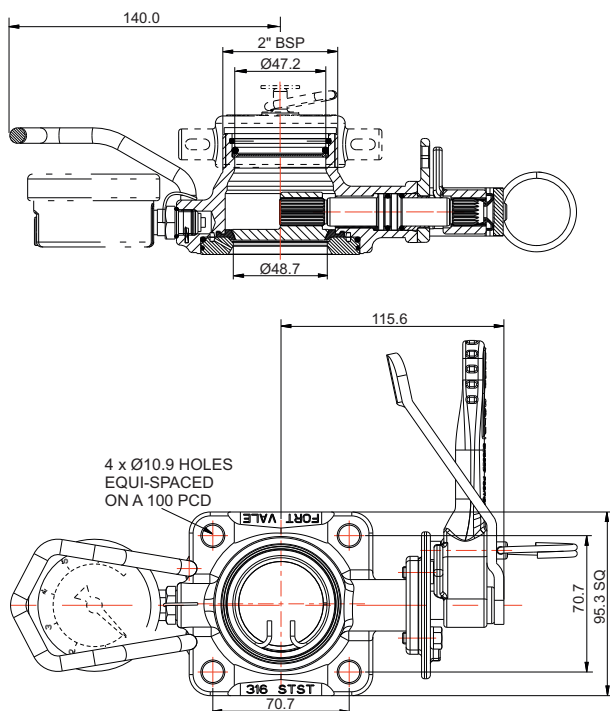



# 2" BSP Airline Butterfly Valve

Part No: 535/0200

## Parts Drawing

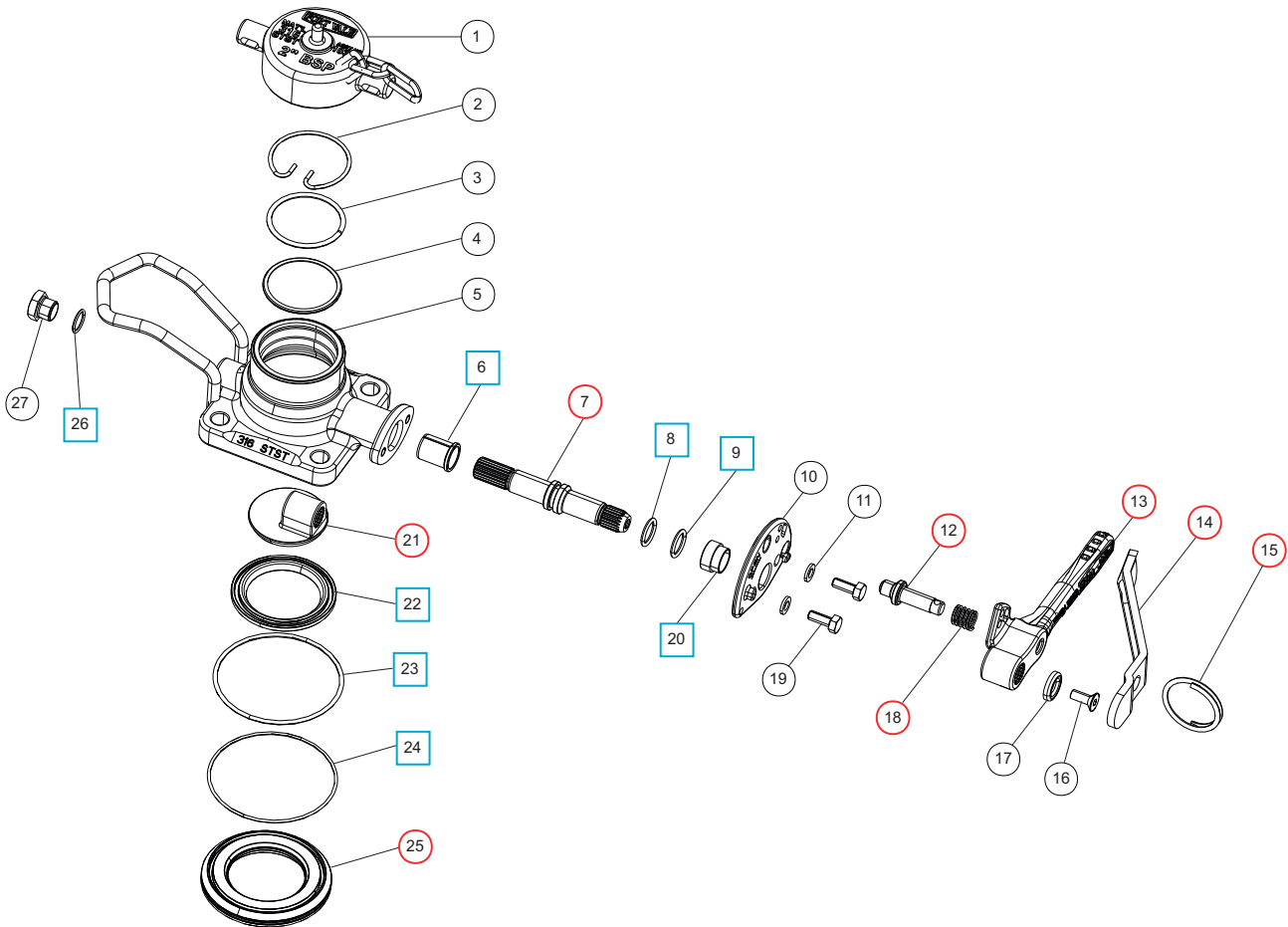

### Parts List

Item	Description	Part No.
1	2" BSP dust cap (supplied separately)	10301PS
2	Snap ring * <b>Note 1 &amp; 2</b>	5120-005
3	Spacer * <b>Note 1 &amp; 2</b>	355/0295
4	Gauze filter * <b>Note 1</b> Sintered filter (2) * <b>Note 2</b>	355/0010 355/0206
5	Body	535/0215
6	PTFE bush	535/0009 <input type="checkbox"/> <input type="radio"/>
7	Spindle	535/0203 <input type="radio"/>
8	Viton O ring	20361 <input type="checkbox"/> <input type="radio"/>
9	PTFE O ring	20363 <input type="checkbox"/> <input type="radio"/>
10	Stuffing clamp	535/0204
11	Spring washer (2)	5113-008
12	Handle location pin	368/0010 <input type="radio"/>
13	Handle	535/0050 <input type="radio"/>
14	Operating lever	368/9838 <input type="radio"/>
15	Split ring	368/0011 <input type="radio"/>
16	Countersunk bolt	5111-030
17	Retaining washer	20370
18	Handle spring	368/0012 <input type="radio"/>

### Parts List

Item	Description	Part No.
19	Hex bolt (2)	5111-022
20	PTFE stuffing clamp bush	368/0301 <input type="checkbox"/> <input type="radio"/>
21	Closure plate	535/0225 <input type="radio"/>
22	PTFE main seal	355/0202 <input type="checkbox"/> <input type="radio"/>
23	PTFE O ring	5005-659 <input type="checkbox"/> <input type="radio"/>
24	EPDM O ring	5005-664 <input type="checkbox"/> <input type="radio"/>
25	Clamp plate	535/0201 <input type="radio"/>
26	PTFE O ring	5005-048 <input type="checkbox"/> <input type="radio"/>
27	1/4" BSP plug	5128-005

**NOTE 1:** Optional part, see Range 535/0200F

**NOTE 2:** Optional part, see Range 535/0200S

### Seal Kit

Description	Part No.
All parts marked <input type="checkbox"/> in the Parts List	535/00SK

### Repair Kit

Description	Part No.
All parts marked <input type="radio"/> in the Parts List	535/00RK





# 2" MKII Flanged Airline Butterfly Valve

Part No: 535/3000

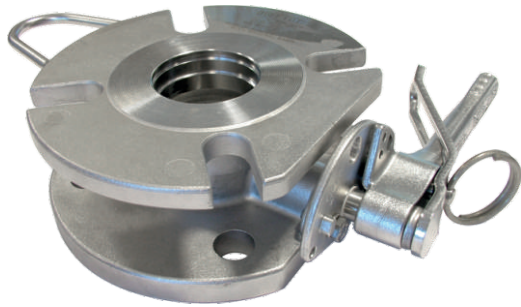

## Specification

### Nominal size

50mm

### Tank connection

Flanged: 4 x 18mm holes on a 125mm PCD (DIN50 PN10)

### Outlet/Process connection

Flanged: 4 x open slots, min. PCD: 2" BSTD

### Properties

1/4" BSP gauge connection, gauge guard, handle with TIR

### Materials

Contact parts: 316 stainless steel

Main seal: PTFE

Alternatives are available, refer to the Design Options page

## Design Conditions

Weight:	5.9 Kg
Design Pressure (MAWP):	6.9 Bar
Test Pressure:	12.6 Bar
Design Temperature Min:	-40°C
Design Temperature Max:	190°C

**NOTE:** The Design Conditions and Section View dimensions are for the specified part number only.

### Design Code

BS EN14432

## Range

Description	Part No.
Standard specification	535/3000
With gauze filter	535/3000F
With sintered filter	535/3000S
With TIR wire to 1/4" BSP plug	535/3000W

## Related Parts

Description	Part No.
Blind flange	370/4239CM
Inlet gasket	5005-360
Pressure gauge	920/07BBSP
Gauge adaptor	352/4004
Stud kit	311/3700
Outlet gasket	5005-361
Weld-in flange	355/3100

## Section View

GAUZE FILTER WITH SNAP RING & SPACER (SUFFIX F)

SINTERED FILTERS WITH SNAP RING & SPACER (SUFFIX S)

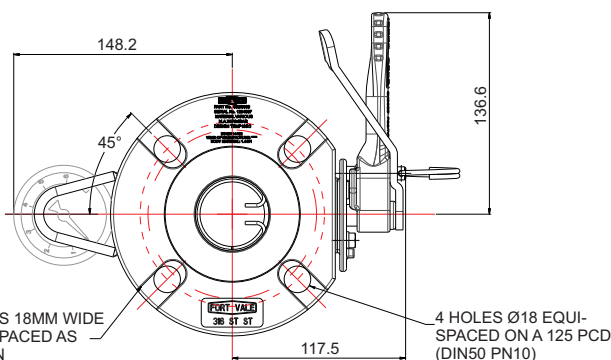
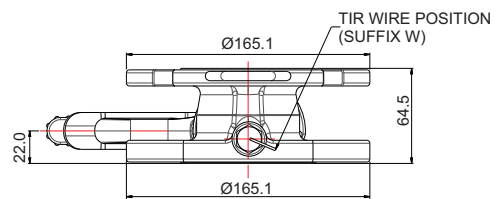
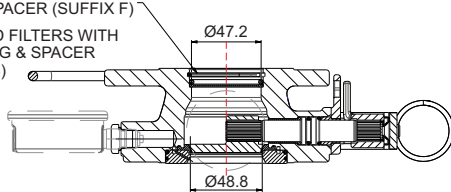



# 2" MKII Flanged Airline Butterfly Valve

Part No: 535/3000

## Parts Drawing

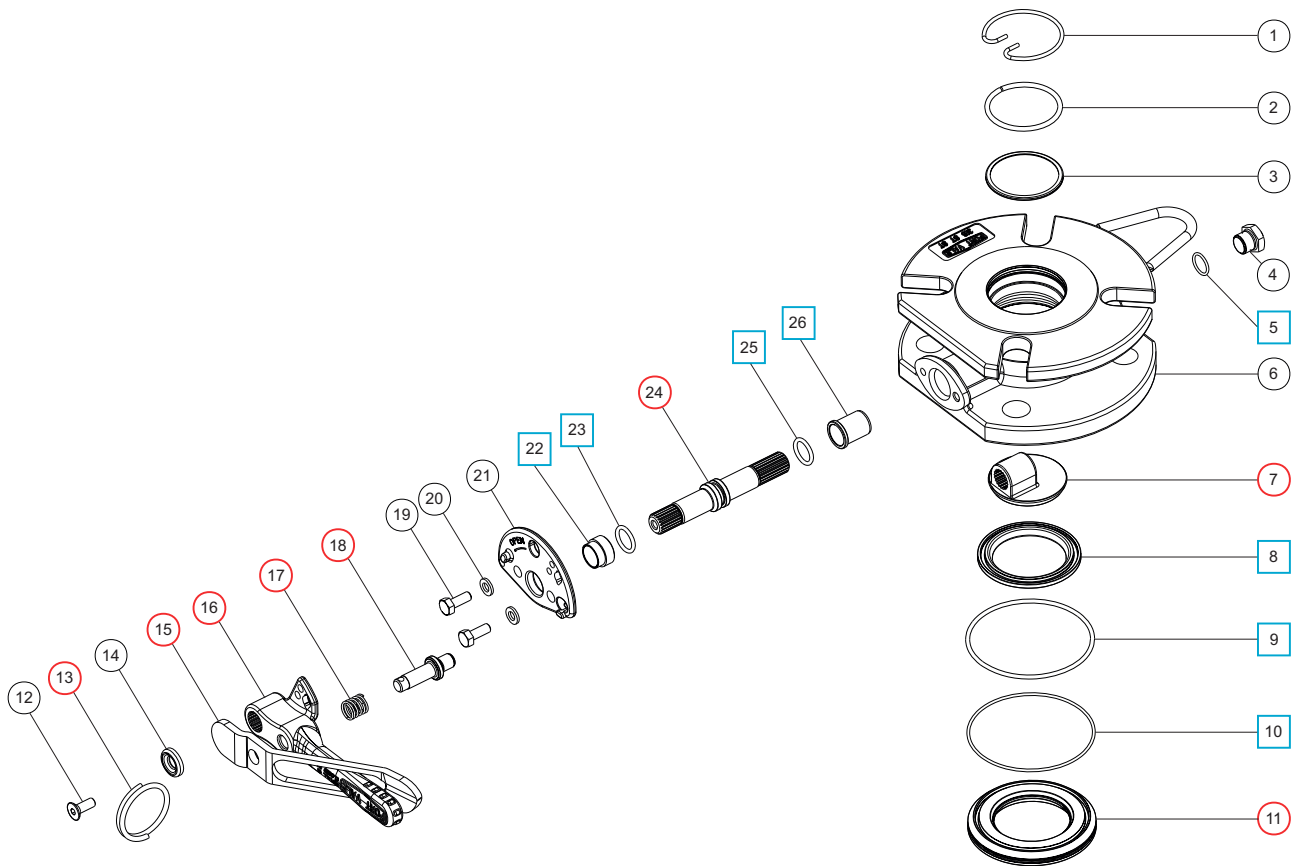

### Parts List

Item	Description	Part No.
1	Snap ring <b>*Note 1 &amp; 2</b>	5120-005
2	Spacer <b>*Note 1 &amp; 2</b>	355/0295
3	Gauze filter <b>*Note 1</b>	355/0010
	Sintered filter (2) <b>*Note 2</b>	355/0206
4	1/4" BSP plug	5128-005
5	PTFE O ring	5005-048 <input type="checkbox"/> <input type="radio"/>
6	Body	535/3015
7	Closure plate	535/0225 <input type="radio"/>
8	Main seal	355/0202 <input type="checkbox"/> <input type="radio"/>
9	PTFE O ring	5005-659 <input type="checkbox"/> <input type="radio"/>
10	EPDM O ring	5005-664 <input type="checkbox"/> <input type="radio"/>
11	Seal plate	535/0201 <input type="radio"/>
12	M6 screw	5111-030
13	Split ring	368/0011 <input type="radio"/>
14	Retaining washer	20370
15	Operating lever	368/9838 <input type="radio"/>
16	Handle	535/0050 <input type="radio"/>
17	Handle spring	368/0012 <input type="radio"/>
18	Location pin	368/0010 <input type="radio"/>
19	M6 hex bolt (2)	5111-022

### Parts List

Item	Description	Part No.
20	M6 spring washer (2)	5113-008
21	Stuffing clamp	535/0204C
22	Stuffing bush	368/0301 <input type="checkbox"/> <input type="radio"/>
23	PTFE O ring	20363 <input type="checkbox"/> <input type="radio"/>
24	Spindle	535/0203 <input type="radio"/>
25	Viton O ring	20361 <input type="checkbox"/> <input type="radio"/>
26	PTFE bearing	535/0009 <input type="checkbox"/> <input type="radio"/>

**NOTE 1:** Optional part, see Range 535/3000F

**NOTE 2:** Optional part, see Range 535/3000S

### Seal Kit

Description	Part No.
All parts marked <input type="checkbox"/> in the Parts List	535/00SK

### Repair Kit

Description	Part No.
All parts marked <input type="radio"/> in the Parts List	535/00RK



# Airline Ball Valves & Airline Butterfly Valves

## Installation Options

### 1½" Airline Ball Valves

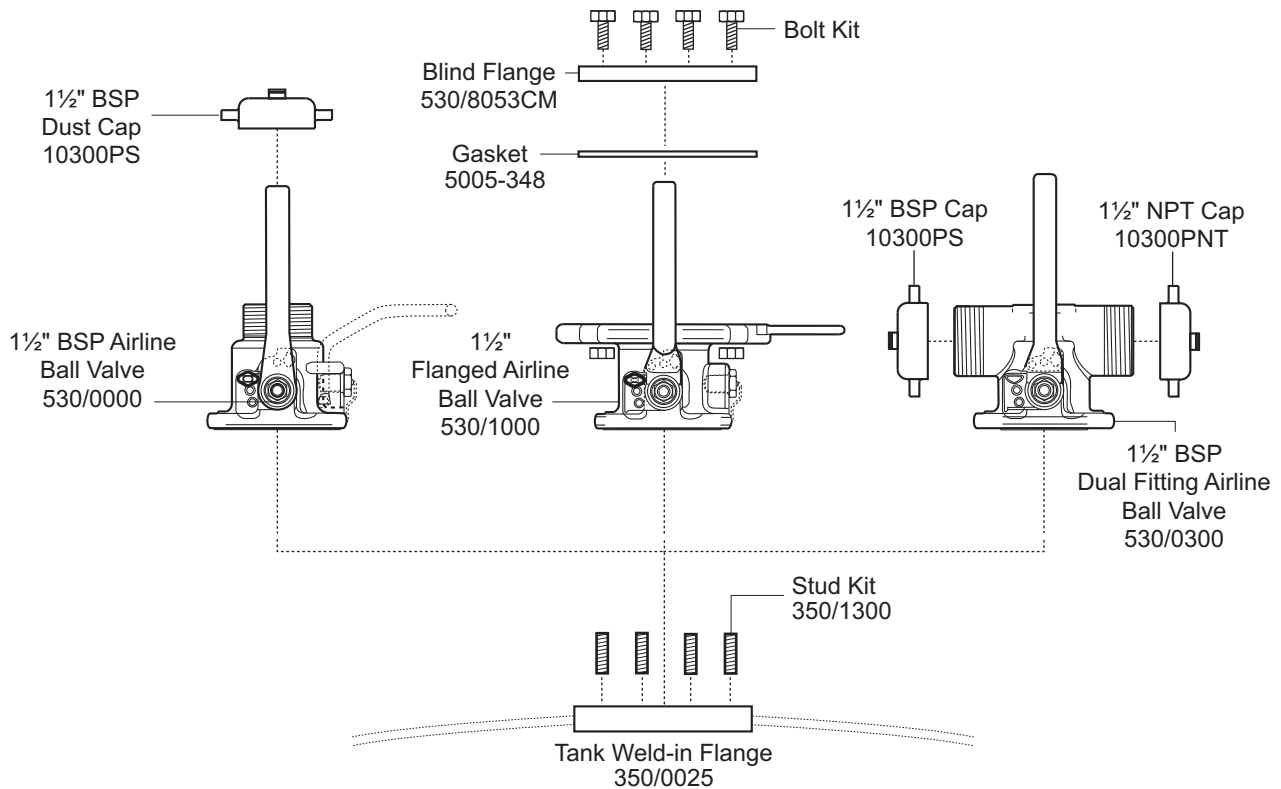

### 2" Airline Butterfly Valves

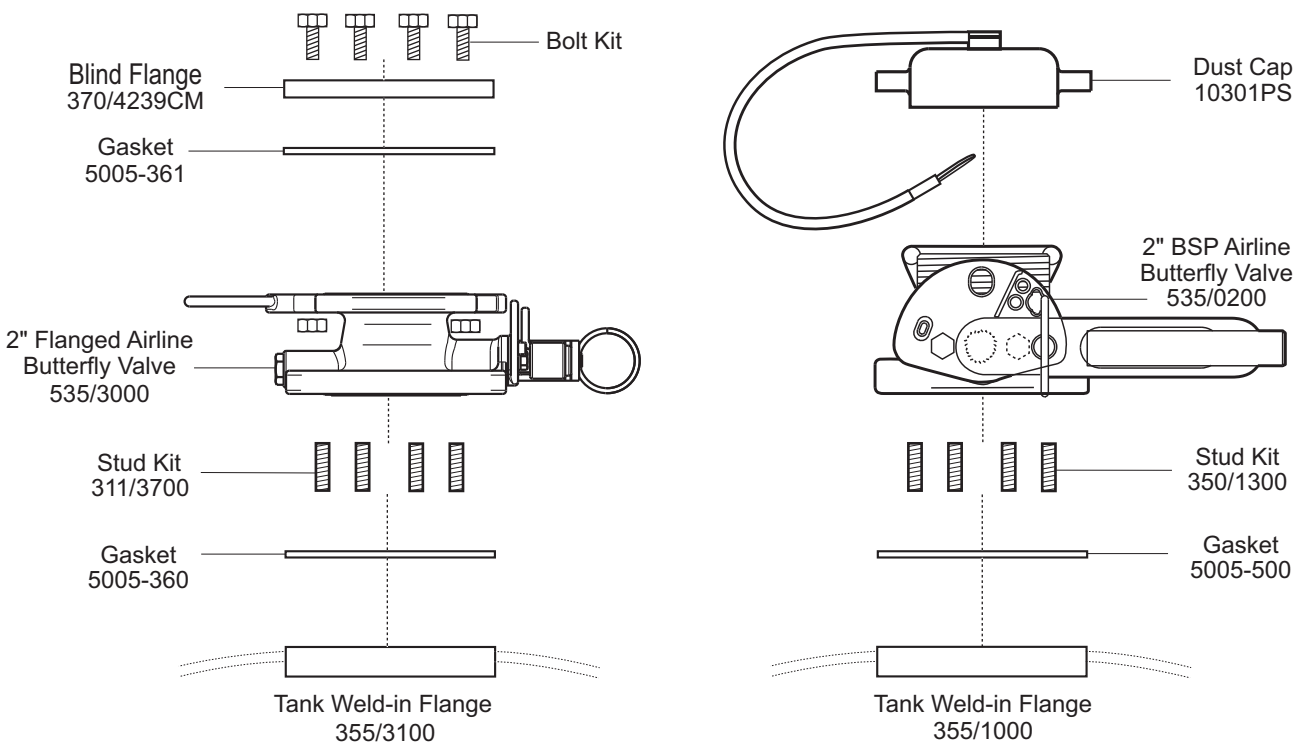





# Bottom Discharge Valves

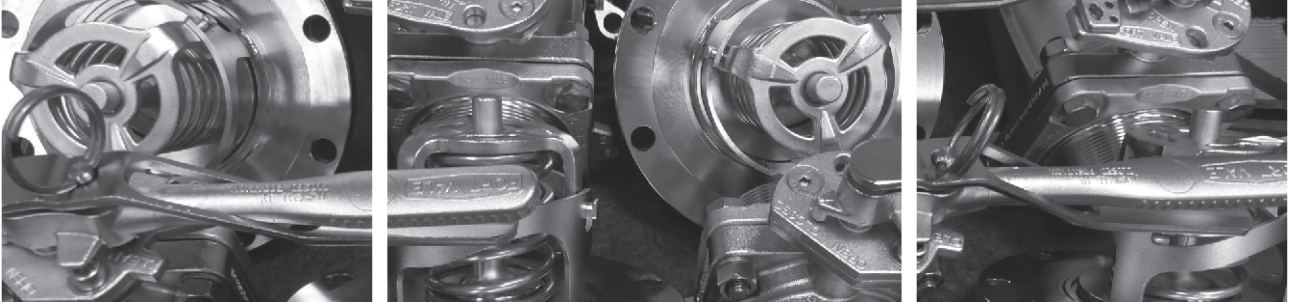





# Footvalves

## Design Options

### Function

A footvalve is a primary closure valve that is installed at the drain point of a tank. It is used to load and discharge cargo in combination with a secondary closure valve. The footvalve body has a shear groove. To prevent leakage if there was an accident, the groove will break and keep the internal part of the valve closed and attached to the tank.

In our standard range, we offer two main types of footvalve; Cleanflow and Highlift.



#### Cleanflow

The Cleanflow footvalve does not protrude into the tank. When the valve is open, the poppet does not obstruct the discharge orifice, so the cargo discharges faster.



#### Highlift

The Highlift footvalve has a traditional internal cage and a spring-loaded poppet with a lifting finger.

### Design Options

The design options below are available on our standard range of Cleanflow and Highlift footvalves.

#### Nominal Bore

80mm (3")

100mm (4")

#### Special service conditions:

125mm (5")

150mm (6")

Reduced bore: 80mm to 50mm (3" to 2")



#### Body Style

Angle between the inlet & outlet flange

30°

45°

90°

180°

#### Special service conditions:

105° - Cleanflow only

#### Outlet Flange

Round and square flanges

4, 6 and 8 hole drilling patterns

Flats milled top and bottom



#### Operation

Manually operated: A range of handles is available

Pneumatically actuated

Hydraulically actuated

#### Main Seal

Fortyt

#### Special service conditions:

A range of seal materials is available

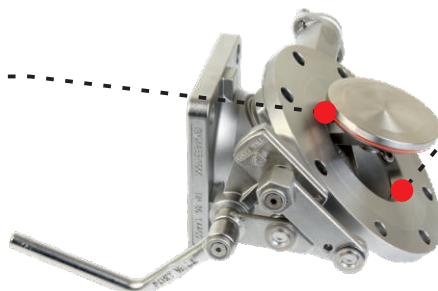

#### Inlet/Seat Area

Supersat: Alloy 625 integral seat

#### Special service conditions:

Replaceable seat:

High nickel alloy, e.g. Alloy C276, 904L stainless steel or special metals, e.g. Titanium GR2

### Design Options - continued

#### Valve Materials

316 stainless steel

#### Special service conditions:

Lined wetted parts, e.g. PFA, Halar ®

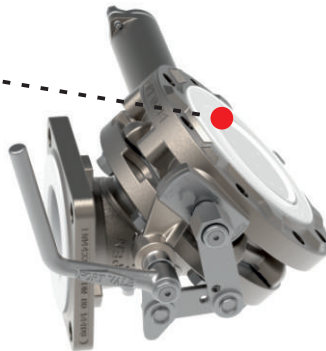

#### Special Cargoes

##### Solidifying cargo:

Body with steam-heating chamber

Conical poppet

##### Sensitive cargo:

Sample point

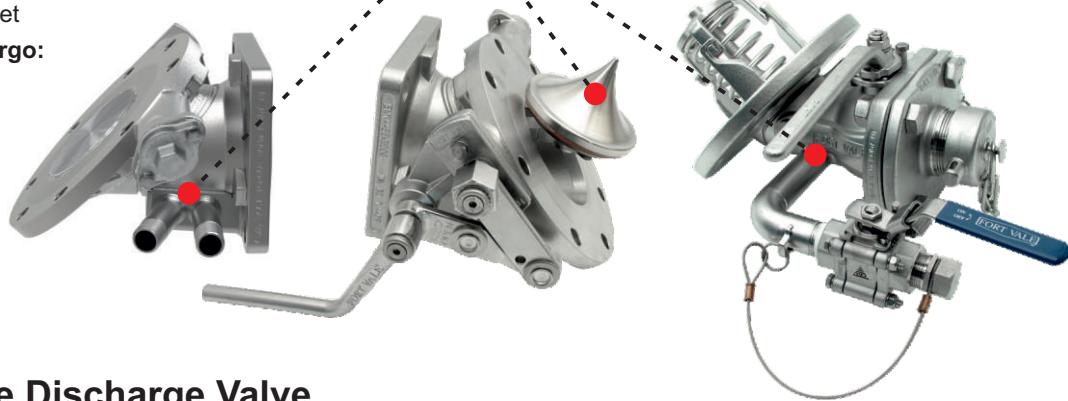

### Composite Discharge Valve

A composite discharge valve is a combined primary and secondary closure valve. It saves space and reduces the number of joints between valves. Many of our design options are available on composite valves.

Please contact us for more information.

### Related Parts

We recommend our range of compatible accessories:

- Remote closure systems and fusible elements
- Flanges - weld-in and adaptor
- Fasteners
- Gaskets

Please contact us for more information about these parts.

### Footvalves for Dedicated Service

We offer a range of footvalves and discharge systems for these service conditions and special cargoes:

- Offshore fuel and chemical tanks
- T50 tank containers for liquefied gas
- Rail tank wagons
- Road tankers carrying hot product (bitumen)
- Road tankers: top operated screwdown valve

Please contact us for more information about these valves.





# 3" 45° Cleanflow Footvalve

Part No: 845/1200A



## Specification

### Nominal size/body angle

80mm / 45°

### Inlet connection

Flanged: 8 x 14mm holes equi-spaced on a 178mm PCD

### Outlet connection

Flanged: 4 x 17mm holes on a 160mm PCD

### Materials

Seating area: Superseat (alloy 625)

Contact parts: 316 stainless steel

Main seal: Fortyt

Alternatives are available, refer to the Design Options page

## Design Conditions

Weight:	9.87 Kg
Design Pressure (MAWP):	4 Bar
Test Pressure:	6 Bar
Design Temperature Min:	-40°C
Design Temperature Max:	200°C

**NOTE:** The Design Conditions and Section View dimensions are for the specified part number only.

### Approvals

BS EN 14433

Design Approval by Lloyds Register of Shipping

## Range

Description	Part No.
Standard specification	845/1200A
With alloy C276 seating area	845/1200AHS

## Related Parts

Description	Part No.
Weld-in flange	324/9000
Stud kit	845/2040
CNAF/PTFE inlet gasket	5005-015
CNAF/PTFE outlet ring gasket	5005-049
CNAF/PTFE outlet gasket - 6 hole	5005-169
Valve operation decal	845/0320

## Section View

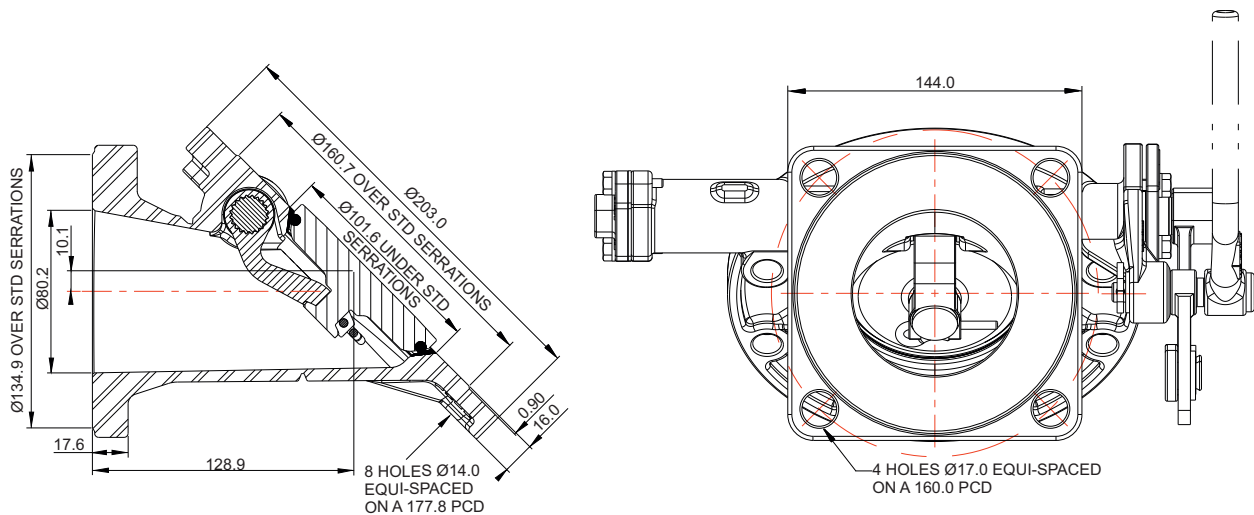



# 3" 45° Cleanflow Footvalve

Part No: 845/1200A

## Parts Drawing

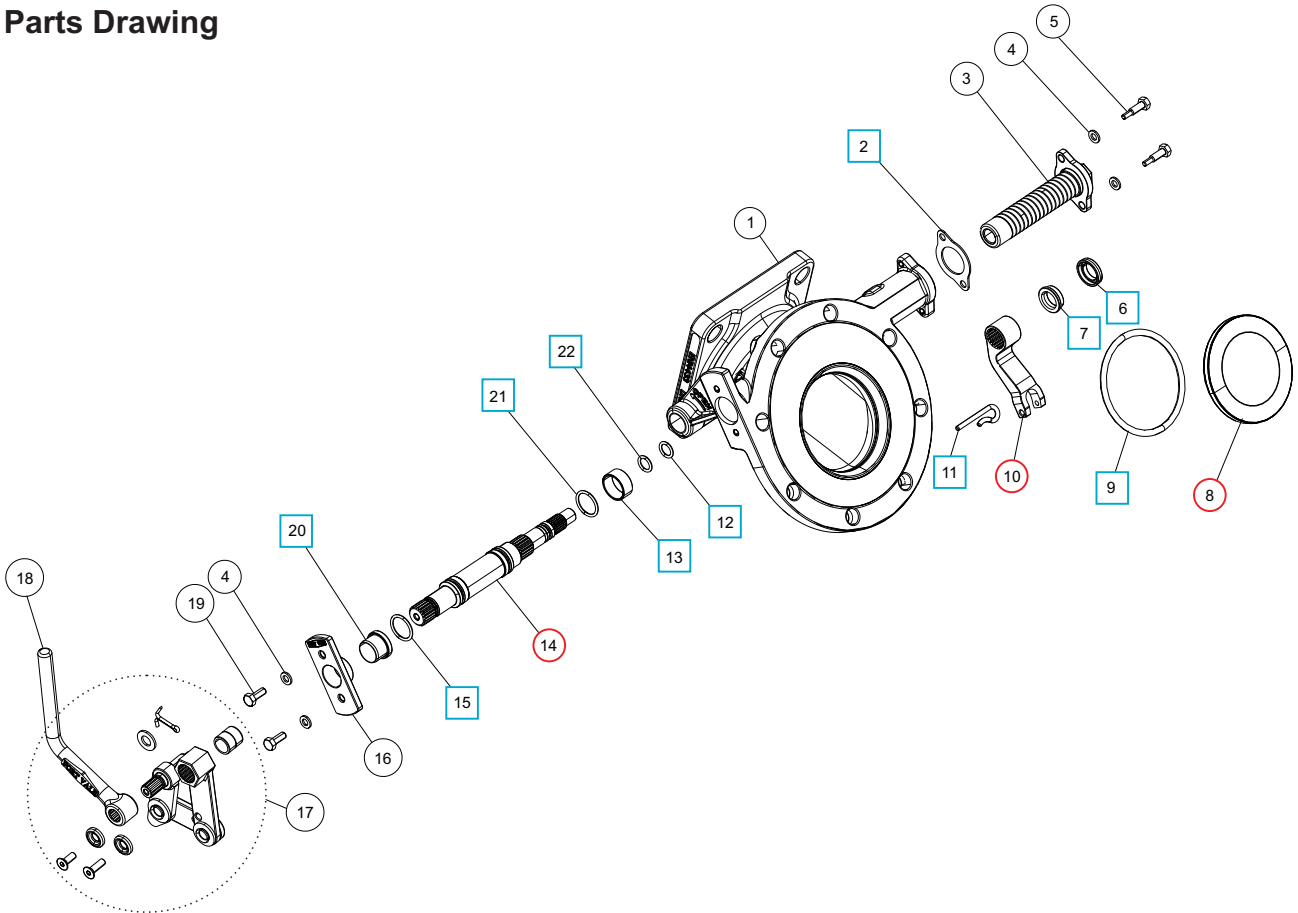

## Parts List

Item	Description	Part No.
1	Body	845/1100B
2	Spring housing gasket	5005-845 <input type="checkbox"/> <input type="radio"/>
3	Spring assembly	845/0050
4	M6 spring washer (4)	5113-008
5	M6 hex bolt (2)	845/0017
6	Bush seal	845/0064 <input type="checkbox"/> <input type="radio"/>
7	Seal energizer	845/0063 <input type="checkbox"/> <input type="radio"/>
8	Poppet	845/0040 <input type="radio"/>
9	Fortyt O ring	5005-104 <input type="checkbox"/> <input type="radio"/>
10	Lifting fork	845/0010 <input type="radio"/>
11	Retaining pin	845/0015 <input type="checkbox"/> <input type="radio"/>
12	Perlast O ring	10133PHT <input type="checkbox"/> <input type="radio"/>
13	Spindle bearing	845/0062 <input type="checkbox"/> <input type="radio"/>
14	Spindle <b>*Note</b>	845/0200 <input type="radio"/>
15	Viton O ring	5005-336 <input type="checkbox"/> <input type="radio"/>
16	Stuffing clamp flange	845/0016
17	Handle linkage assembly	324/8910
18	Handle <b>*Refer to Handle Options Table</b>	
19	M6 X 16mm hex bolt (2)	5111-022
20	Stuffing seal	845/0061 <input type="checkbox"/> <input type="radio"/>
21	Perlast O ring	5005-384 <input type="checkbox"/> <input type="radio"/>
22	PTFE O ring	5005-008 <input type="checkbox"/> <input type="radio"/>

## Footvalve Handle Options

Specification	Type	Part No.
Std. Cleanflow handle		324/8670
Cranked Cleanflow handle		324/8671
Std. Highlift handle		330/5010

**NOTE:** We can supply the spindle with the seals installed. Part no. **845/0200S** includes item 6, 7, 12, 13, 14, 15, 20, 21 & 22.

## Seal Kit

Description	Part No.
All parts marked <input type="checkbox"/> in the Parts List	845/00SK

## Repair Kit

Description	Part No.
All parts marked <input type="radio"/> in the Parts List, includes 845/0200S (see <b>NOTE</b> )	845/00RK



# 3" 45° MKIII Highlift Footvalve

Part No: 826/1200A



## Specification

### Nominal size/body angle

80mm / 45°

### Inlet connection

Flanged: 8 x 14mm holes equi-spaced on a 178mm PCD

### Outlet connection

Flanged: 4 x 17mm holes on a 160mm PCD

### Materials

Seating area: Superseat (alloy 625)

Contact parts: 316 stainless steel

Main seal: Fortyt

Alternatives are available, refer to the Design Options page

## Design Conditions

Weight:	8.9 Kg
Design Pressure (MAWP):	4 Bar
Test Pressure:	6 Bar
Design Temperature Min:	-40°C
Design Temperature Max:	200°C

**NOTE:** The Design Conditions and Section View dimensions are for the specified part number only.

### Approvals

BS EN14433

Design Approval by Lloyds Register of Shipping

## Range

Description	Part No.
Standard specification	826/1200A
With alloy C276 seating area	826/1200AHS

## Related Parts

Description	Part No.
Weld-in flange	324/9000
Stud kit	324/2070
CNAF/PTFE inlet gasket	5005-015
CNAF/PTFE outlet gasket	5005-049
Valve operation decal	326/0300

## Section View

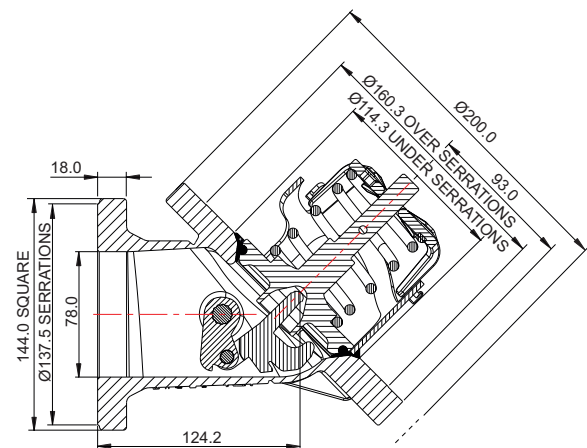
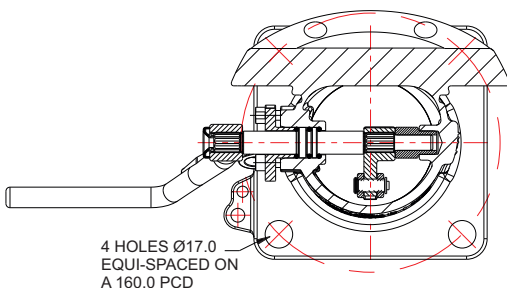
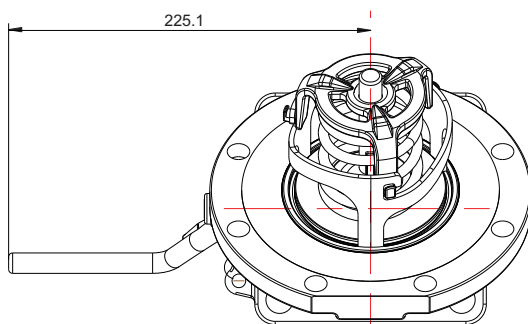



# 3" 45° MKIII Highlift Footvalve

Part No: 826/1200A

## Parts Drawing

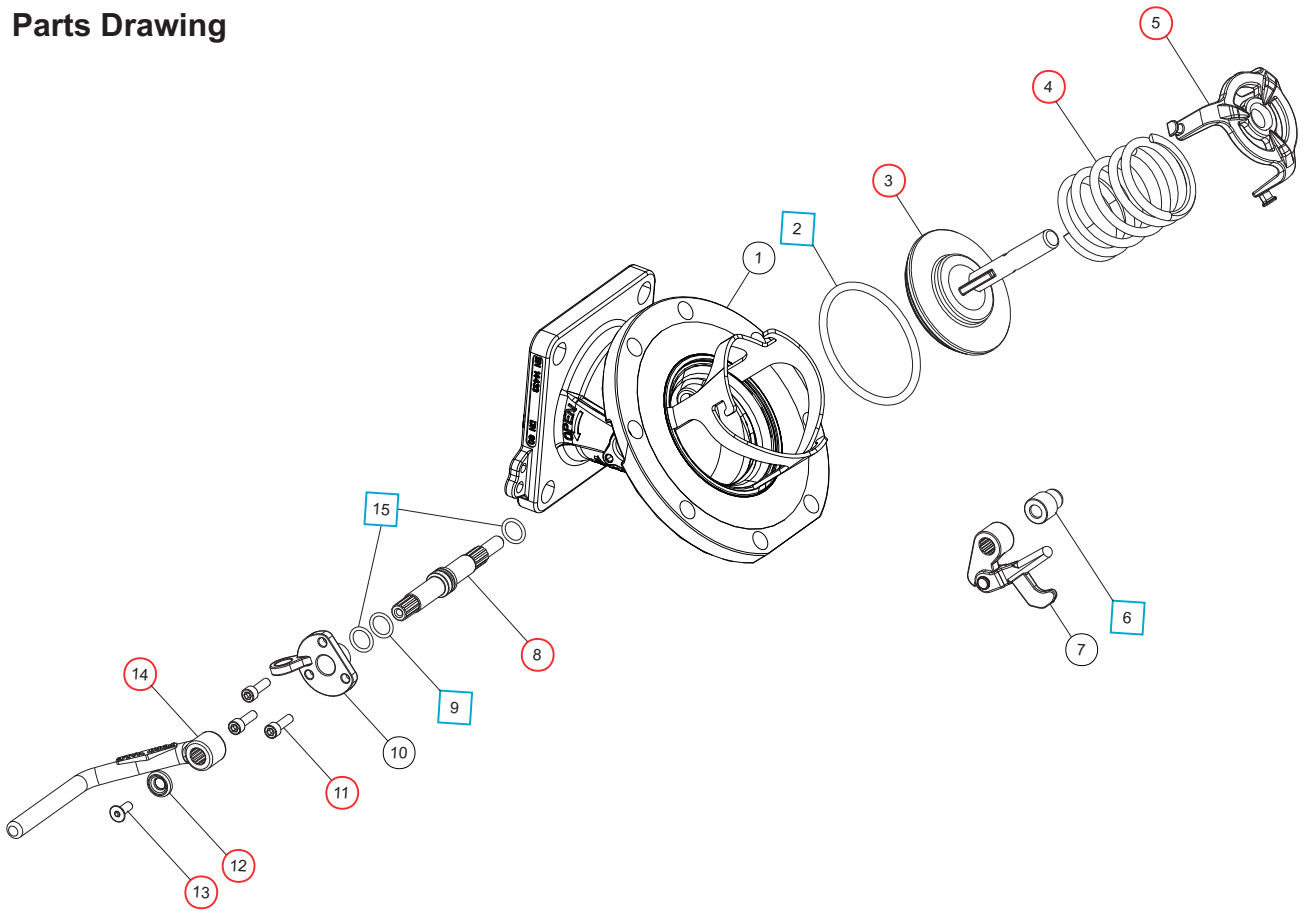

### Parts List

Item	Description	Part No.
1	Body	826/1100B
2	Fortyt O ring	5005-104 <input type="checkbox"/> <input type="radio"/>
3	Solid poppet	324/2020 <input type="radio"/>
4	Spring	5104-971 <input type="radio"/>
5	Spring top plate	290/6104 <input type="radio"/>
6	PTFE crankshaft end bush	20362 <input type="checkbox"/> <input type="radio"/>
7	Crank block assembly	821/0300
8	Spindle	821/0010 <input type="radio"/>
9	Viton O ring	20361 <input type="checkbox"/> <input type="radio"/>
10	Stuffing clamp	324/1001
11	M6 capscrew (3)	5111-017 <input type="radio"/>
12	Handle retaining washer	20370 <input type="radio"/>
13	Handle retaining screw	5111-030 <input type="radio"/>
14	Handle	330/5010 <input type="radio"/>
15	PTFE O ring (2)	20363 <input type="checkbox"/> <input type="radio"/>

### Seal Kit

Description	Part No.
All parts marked <input type="checkbox"/> in the Parts List	826/00SK

### Repair Kit

Description	Part No.
All parts marked <input type="radio"/> in the Parts List	826/00RKA

### Spare Parts

Description	Type	Part No.
Spindle & crank block assy Item 6, 7, 8, 9, & 15		821/0200



# 3" 45° Uniflow Bottom Discharge Assembly

Part No: 806/4000

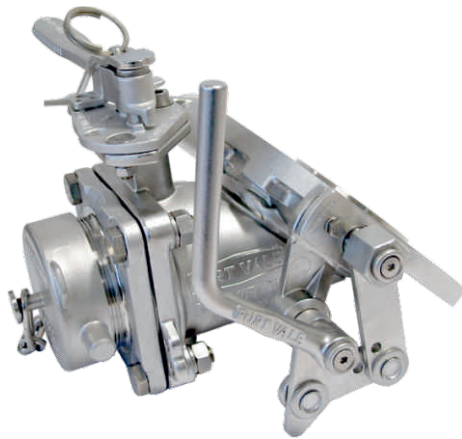

## Specification

**Nominal size/body angle**  
80mm / 45°

**Inlet connection**

Flanged: 8 x 14mm holes equi-spaced on a 178mm PCD

**Outlet connection**

3" BSP spigot flange with cap

**Properties**

Cleanflow footvalve with integral butterfly valve

**Materials**

Seating area: Superseat (alloy 625)

Contact parts: 316 stainless steel

Footvalve main seal: Fortyt

Butterfly valve main seal: PTFE

Cap seal: PTFE

Alternatives are available, refer to the Design Options page

## Design Conditions

Weight:	13.0 Kg
Design Pressure (MAWP):	4 Bar
Test Pressure:	6 Bar
Design Temperature Min:	-40°C
Design Temperature Max:	200°C

**NOTE:** The Design Conditions and Section View dimensions are for the specified part number only.

**Approvals**

BS EN14432

BS EN14433

Design Approval by Lloyds Register of Shipping

## Range

Description	Part No.
Standard specification: 80mm / 45°	806/4000
With alloy C276 seating area	806/4000HS
Standard specification: 80mm / 30°	807/4000

## Related Parts

Description	Part No.
Weld-in flange	324/9000
Stud kit	845/2040
CNAF/PTFE inlet gasket	5005-015
Valve operation decal	326/0303

## Section View

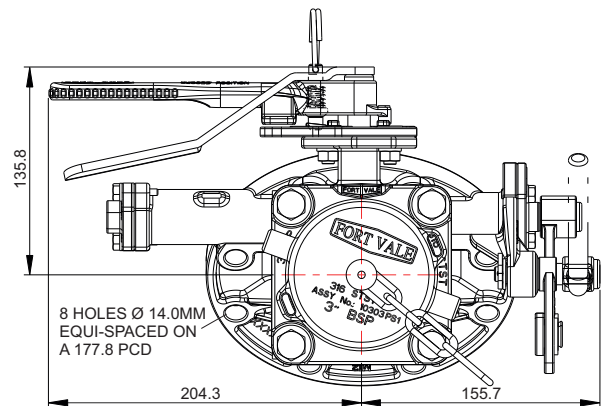
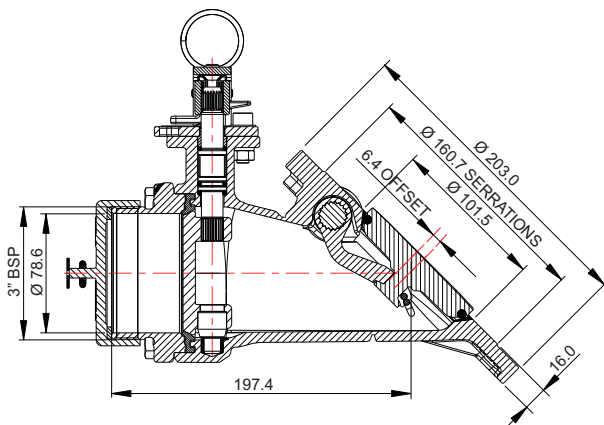



# 3" 45° Uniflow Bottom Discharge Assembly

Part No: 806/4000

## Parts Drawing

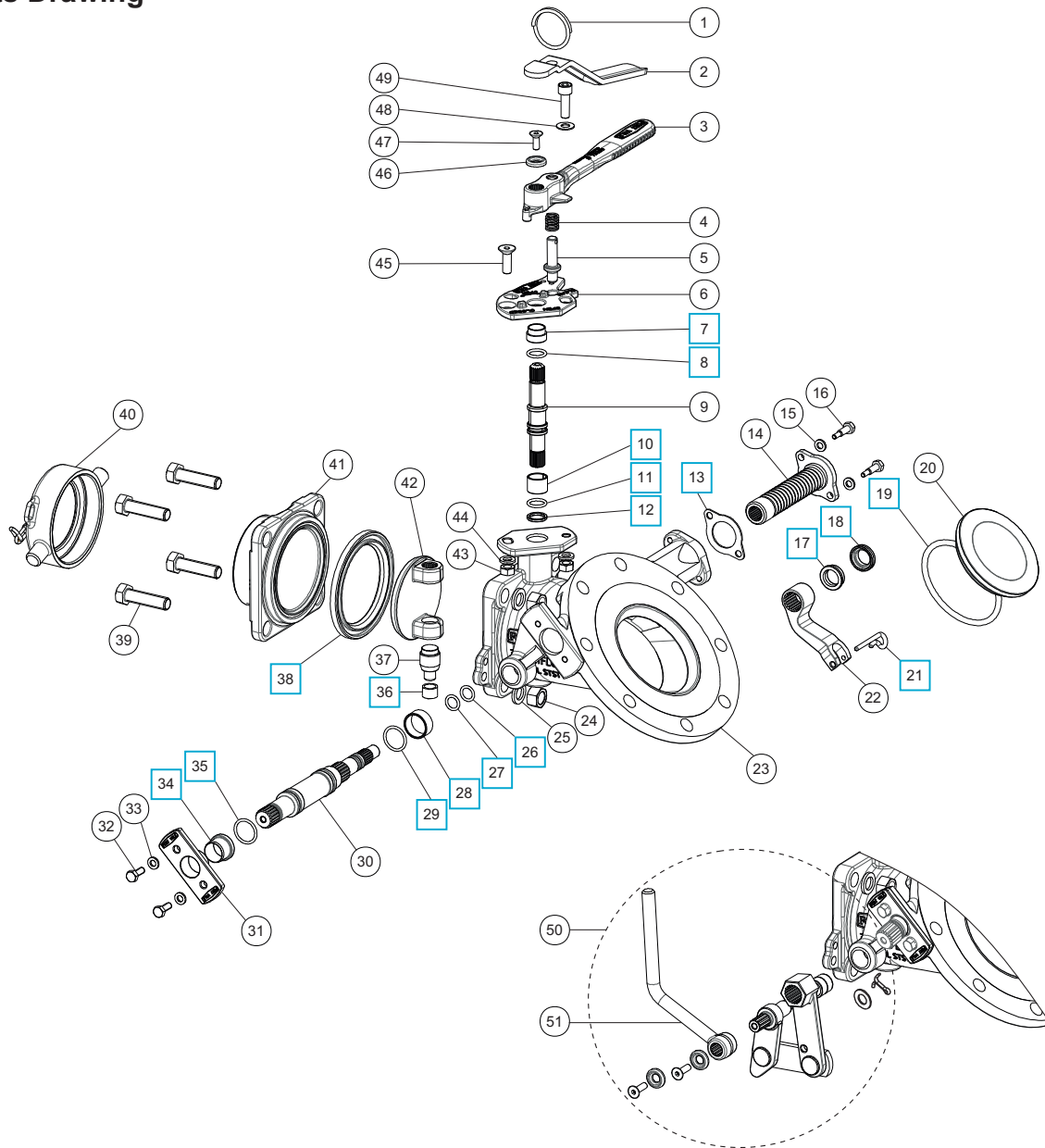



## 3" 45° Uniflow Bottom Discharge Assembly

Part No: 806/4000



### Parts List

Item	Description	Part No.	
1	Split ring	368/0011	
2	Handle lever	368/9837	
3	Butterfly valve handle	368/0057	
4	Handle location spring	368/0012	
5	Handle location pin	368/0010	
6	Stuffing clamp	368/0047	
7	Stuffing clamp bush	368/0301	<input type="checkbox"/>
8	PTFE O ring	20363	<input type="checkbox"/>
9	Spindle	368/0201	
10	Split bearing	252/0517	<input type="checkbox"/>
11	Viton O ring	20361	<input type="checkbox"/>
12	PTFE spindle seat	368/0009	<input type="checkbox"/>
13	Spring boss gasket	5005-845	<input type="checkbox"/>
14	Spring assembly	845/0050	
15	Spring washer (2)	5113-008	
16	Clamp screw (2)	845/0017	
17	Seal energizer	845/0063	<input type="checkbox"/>
18	Bush seal	845/0064	<input type="checkbox"/>
19	Fortyt O ring	5005-104	<input type="checkbox"/>
20	Poppet	845/0040	
21	Retaining pin	845/0015	<input type="checkbox"/>
22	Lifting fork	845/0010	
23	Body	845/1107B	
24	M12 full nut (4)	5112-006	
25	M12 spring washer (4)	5113-010	
26	Perfluoroelastomer O ring	10133PHT	<input type="checkbox"/>
27	PTFE O ring	5005-008	<input type="checkbox"/>
28	Spindle bearing	845/0062	<input type="checkbox"/>
29	Perlast O ring	5005-384	<input type="checkbox"/>
30	Spindle	845/0200	
31	Stuffing clamp	845/0016	
32	Clamp bolt (2)	5111-022	
33	Spring washer (2)	5113-008	
34	Stuffing seal	845/0061	<input type="checkbox"/>
35	Viton O ring	5005-336	<input type="checkbox"/>
36	PTFE bottom bush	368/0035	<input type="checkbox"/>
37	Bottom spindle	368/0036	
38	PTFE butterfly valve main seal	368/0002	<input type="checkbox"/>
39	M12 hex bolt (4)	5111-023	
40	3" BSP cap with chain & seal	10303PS1	
41	Outlet flange	368/5129	
42	Closure plate	368/0400	
43	M8 full nut (2)	5112-001	
44	M8 spring washer (2)	5113-003	
45	M8 countersunk bolt	5111-085	
46	Retaining washer	20370	
47	M6 set screw	5111-030	

### Parts List

Item	Description	Part No.
48	M8 plain washer	5113-005
49	M8 cap screw	5111-148
50	Handle linkage assembly	324/8910
51	Handle *Refer to Handle Options Table	

### Footvalve Handle Options

Specification	Type	Part No.
Std. Cleanflow handle		324/8670
Cranked Cleanflow handle		324/8671
Std. Highlift handle		330/5010

### Seal Kit

Description	Part No.
All parts marked <input type="checkbox"/> in the Parts List	806/40SK







# 3" 45° Univalve Bottom Discharge Assembly

Part No: 804/4000A

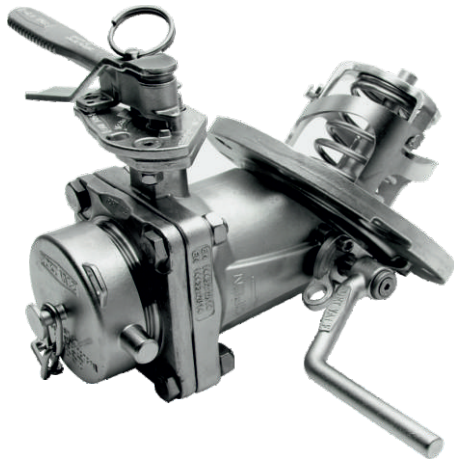

## Specification

**Nominal size/body angle**  
80mm / 45°

**Inlet connection**

Flanged: 8 x 14mm holes equi-spaced on a 178mm PCD

**Outlet connection**

3" BSP spigot flange with cap

**Properties**

Highlift footvalve with integral butterfly valve

**Materials**

Seating area: Superseat (alloy 625)

Contact parts: 316 stainless steel

Footvalve main seal: Fortyt

Butterfly valve main seal: PTFE

Cap seal: PTFE

Alternatives are available, refer to the Design Options page

## Design Conditions

Weight:	12.1 Kg
Design Pressure (MAWP):	4 Bar
Test Pressure:	6 Bar
Design Temperature Min:	-55°C
Design Temperature Max:	200°C

**NOTE:** The Design Conditions and Section View dimensions are for the specified part number only.

**Approvals**

BS EN14432

BS EN14433

Design Approval by Lloyds Register of Shipping

## Range

Description	Part No.
Standard specification	804/4000A
With alloy C276 seating area	804/4000AHS
Superseat; 3" camlock outlet & cap	804/4020A

## Related Parts

Description	Part No.
Weld-in flange	324/9000
Stud kit	324/2070
CNAF/PTFE inlet gasket	5005-015
Valve operation decal	326/0302

## Section View

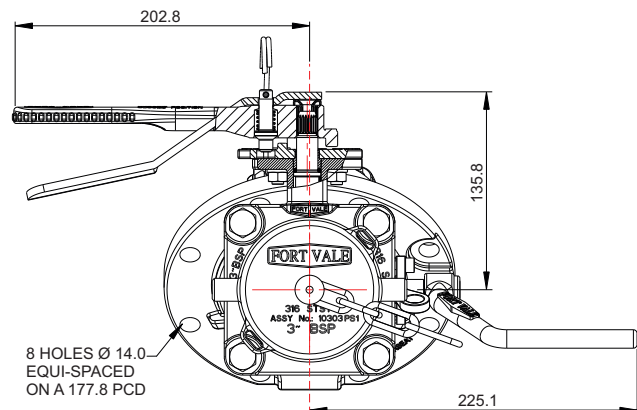
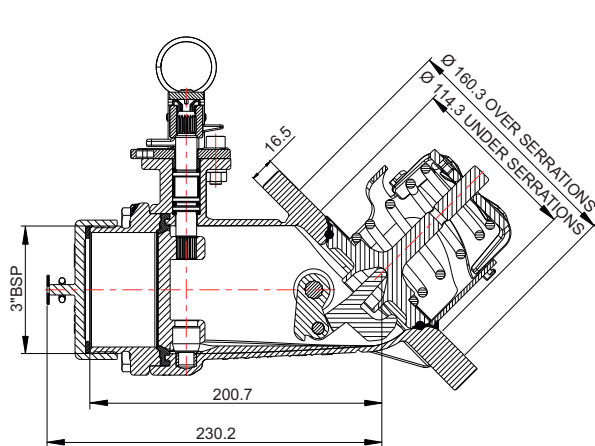



# 3" 45° Univalve Bottom Discharge Assembly

Part No: 804/4000A

## Parts Drawing

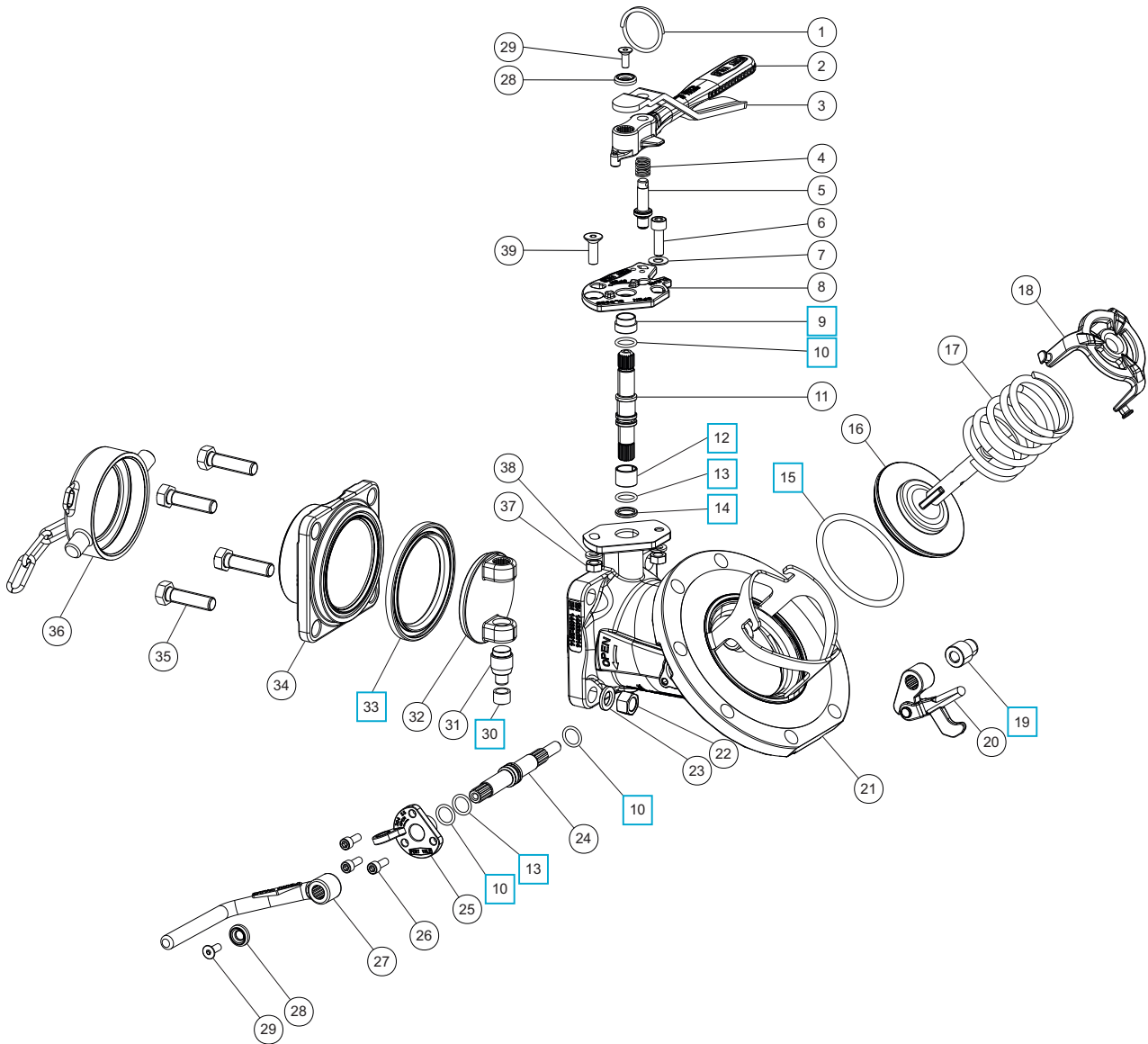



## 3" 45° Univalve Bottom Discharge Assembly

Part No: 804/4000A

### Parts List

Item	Description	Part No.
1	Split ring	368/0011
2	Butterfly valve handle	368/0057
3	Handle lever	368/9837
4	Handle location spring	368/0012
5	Handle location pin	368/0010
6	M8 cap screw	5111-148
7	M8 plain washer	5113-005
8	Stuffing clamp	368/0047
9	Stuffing clamp bush	368/0301 <input type="checkbox"/>
10	PTFE O ring (3)	20363 <input type="checkbox"/>
11	Spindle	368/0201
12	Split bearing	252/0517 <input type="checkbox"/>
13	Viton O ring (2)	20361 <input type="checkbox"/>
14	PTFE spindle seat	368/0009 <input type="checkbox"/>
15	Fortyt O ring	5005-104 <input type="checkbox"/>
16	Poppet	324/2020
17	Closure spring	5104-971
18	Spring top plate	290/6104
19	PTFE crankshaft end bush	20362 <input type="checkbox"/>
20	Crank block & lifting finger	821/0300
21	Body assembly	826/1252B
22	M12 full nut (4)	5112-006
23	M12 spring washer (4)	5113-010
24	Spindle	821/0010
25	Stuffing clamp	324/1001
26	M6 cap screw (3)	5111-017
27	Footvalve handle	330/5010
28	Retaining washer (2)	20370
29	M6 bolt (2)	5111-030
30	PTFE bottom bush	368/0035 <input type="checkbox"/>
31	Bottom spindle	368/0036
32	Closure plate	368/0400
33	PTFE butterfly valve main seal	368/0002 <input type="checkbox"/>
34	Outlet flange	368/5129
35	M12 hex bolt (4)	5111-023
36	3" BSP cap with chain & seal	10303PS1
37	M8 full nut (2)	5112-001
38	M8 spring washer (2)	5113-003
39	M8 countersunk bolt	5111-085

### Seal Kit

Description	Part No.
All parts marked <input type="checkbox"/> in the Parts List	804/40SK





# Discharge Butterfly Valves

## Design Options

### Function

A discharge butterfly valve is used to load and discharge cargo. It is usually a secondary closure valve that is installed onto a footvalve (primary closure valve) at the drain point of a tank. A butterfly valve can also be used as a primary closure valve on the top of a tank.

**NOTE:** Refer to a separate page for discharge butterfly valves dedicated to Road Tankers.

### Design Options

The design options below are available on our standard range of discharge butterfly valves.

#### Clamped Body

Scrolled face, installed between two flanges



#### Flanged Body

4 or 6 hole drilling patterns  
Dual-drilled hole patterns  
Open slots



#### TW Drilled Body

Compatible with Tankwagen drilling pattern



#### Nominal Bore

50mm (2")  
80mm (3")  
100mm (4")

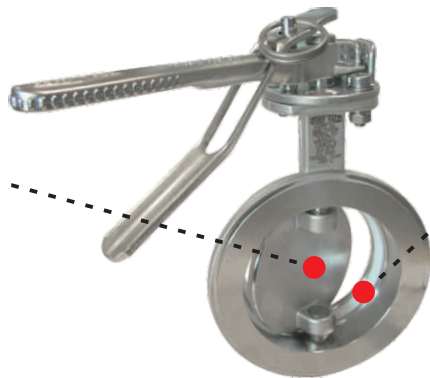

#### Main Seal

PTFE

**Special service conditions:**  
High-temperature compatible seals

#### Operation

Manually operated  
Lockable handle  
Left hand or right hand operation  
Pneumatically actuated





## Discharge Butterfly Valves Design Options

### Design Options - continued

#### Valve Materials

316 stainless steel

#### Special service applications:

Lined wetted parts, e.g. PFA

Wetted parts in high nickel alloys,  
e.g. 904L stainless steel, Alloy C276



#### Special Cargoes

##### Solidifying cargo:

Body with steam-heating connections

Hemispherical closure plate



### Related Parts

We recommend our range of compatible accessories:

- Flanges - inlet, adapter, outlet, blind
- Tertiary closures
- Fasteners
- Gaskets

Please contact us for more information about these parts.

### Discharge Butterfly Valves for Dedicated Service

We offer a range of discharge butterfly valves suitable for these service conditions and special cargoes:

- Road Tankers
- Hygienic service

Please contact us for more information about these valves.



# 3" Clamped Widdop Butterfly Valve

Part No: 368/7000B



## Specification

### Nominal size

80mm

### Body type

Clamped

### Properties

Left hand operated, handle with TIR and padlock slots

### Materials

Contact parts: 316 stainless steel

Main seal: PTFE

Alternatives are available, refer to the Design Options page

## Design Conditions

Weight:	3.5 Kg
Design Pressure (MAWP):	6 Bar
Test Pressure:	10.2 Bar
Design Temperature Min:	-40°C
Design Temperature Max:	200°C

**NOTE:** The Design Conditions and Section View dimensions are for the specified part number only.

### Design Code

BS EN14432

### Design Approvals

Lloyds Register of Shipping  
Rijksdienst  
SNCF  
RMRS

## Range

Description	Part No.
Standard specification	368/7000B
With hemi-spherical closure plate	368/9110B
Std. specification, right hand operated	368/4000A

## Related Parts

Description	Part No.
CNAF/PTFE inlet gasket	5005-049
CNAF/PTFE outlet gasket	5005-490
CNAF/PTFE 4 hole square inlet gasket	5005-198
CNAF/PTFE 4 hole square outlet gasket	5005-195
Bolting kit	368/1100
3" BSP outlet flange	368/8047
3" BSP blank cap with PTFE seal	10303PS
3" camlock outlet flange	368/8058
3" camlock blank cap	90/DC300
3" NPT outlet flange	368/8049
3" NPT blank cap with PTFE washer	425/3250

## Section View

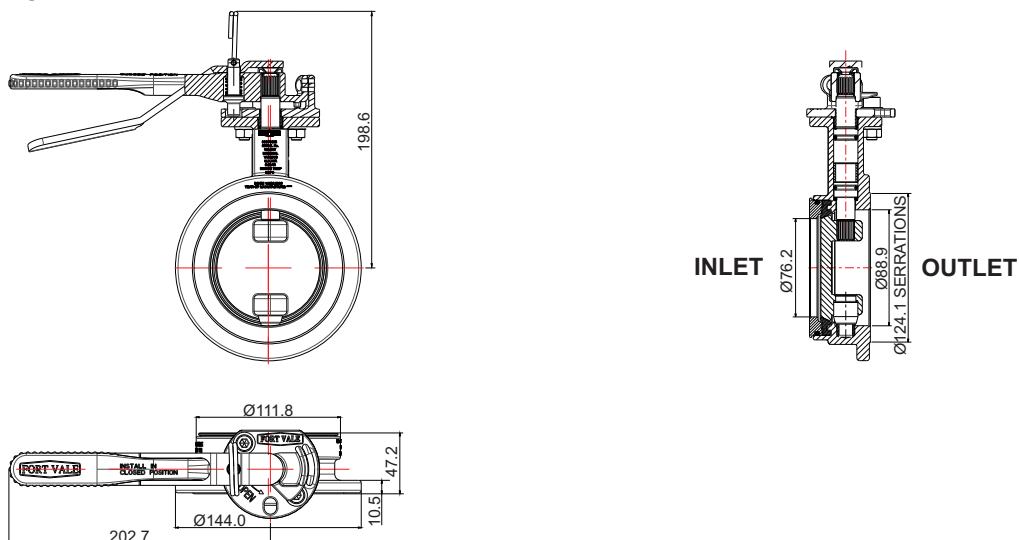



# 3" Clamped Widdop Butterfly Valve

Part No: 368/7000B

## Parts Drawing

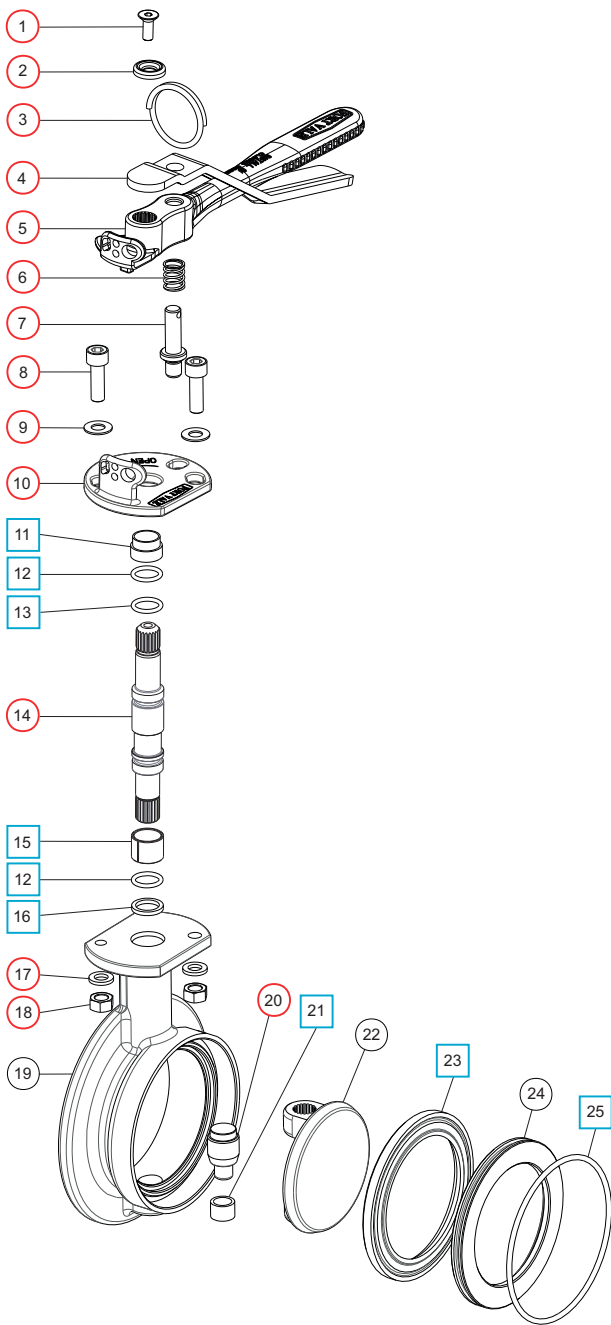

## Parts List

Item	Description	Part No.	
1	M6 set screw	5111-030	○
2	Washer	20370	○
3	Split ring	368/0011	○
4	Operating lever	368/9837	○
5	Handle	368/0050	○
6	Handle location spring	368/0012	○
7	Handle location pin	368/0010	○
8	M8 cap screw (2)	5111-148	○
9	M8 plain washer (2)	5113-005	○
10	Stuffing clamp	368/0040	○
11	PTFE stuffing clamp bush	368/0301	□ ○
12	PTFE O ring (2)	20363	□ ○
13	Viton O ring	20361	□ ○
14	Spindle <b>*Note</b>	368/0200	○
15	Split bearing	252/0517	□ ○
16	PTFE spindle seat	368/0009	□ ○
17	M8 spring washer (2)	5113-003	○
18	M8 full nut (2)	5112-001	○
19	Body	368/0150	
20	Bottom spindle	368/0036	○
21	PTFE bottom bush	368/0035	□ ○
22	Closure plate	368/0400	
23	PTFE main seal	368/0002	□ ○
24	Seal clamp plate	368/0045	
25	Nitrile O ring	5005-342	□ ○

**NOTE:** We can supply the spindle with the seals installed. Part no. **368/0200S** includes item 11 thru 16.

## Seal Kit

Description	Part No.
All parts marked □ in the Parts List	368/00SK

## Repair Kit

Description	Part No.
All parts marked ○ in the Parts List, includes 368/0200S (see <b>NOTE</b> )	368/00RKA





# 3" Clamped Widdop Butterfly Valve - High Temperature

Part No: 368/71HTB



## Specification

### Nominal size

80mm

### Body type

Clamped

### Properties

Left hand operated, handle with TIR and padlock slots

### Materials

Contact parts: 316 stainless steel

Main seal: Flexityt

Alternatives are available, refer to the Design Options page

## Design Conditions

Weight:	3.7 Kg
Design Pressure (MAWP):	6.9 Bar
Test Pressure:	10.35 Bar
Design Temperature Min:	-40°C
Design Temperature Max:	260°C *Note

**NOTE:** The maximum design temperature may be decreased by the maximum working temperature of the inlet/outlet gaskets. Design Conditions and Section View dimensions are for the specified part number only.

### Design Code

BS EN14432

### Design Approvals

Lloyds Register of Shipping  
Rijksdienst  
SNCF  
RMRS

## Range

Description	Part No.
Standard specification	368/71HTB
With hemi-spherical closure plate	368/91HTB

## Related Parts

Description	Part No.
CNAF/PTFE inlet gasket	5005-049HT
CNAF/PTFE outlet gasket	5005-490HT
CNAF/PTFE 4 hole square inlet gasket	5005-198HT
CNAF/PTFE 4 hole square outlet gasket	5005-195HT
Bolting kit	368/1100
3" BSP outlet flange	368/8047
3" BSP blank cap with PTFE seal	10303PS
3" camlock outlet flange	368/8058
3" camlock blank cap	90/DC300
3" NPT outlet flange	368/8049
3" NPT blank cap with PTFE washer	425/3250

## Section View

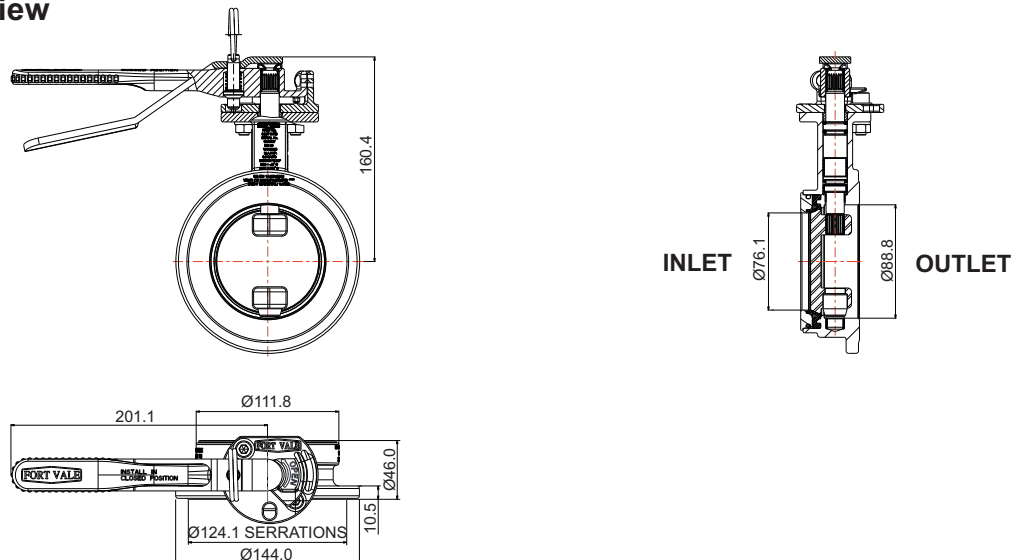



# 3" Clamped Widdop Butterfly Valve - High Temperature

Part No: 368/71HTB

## Parts Drawing

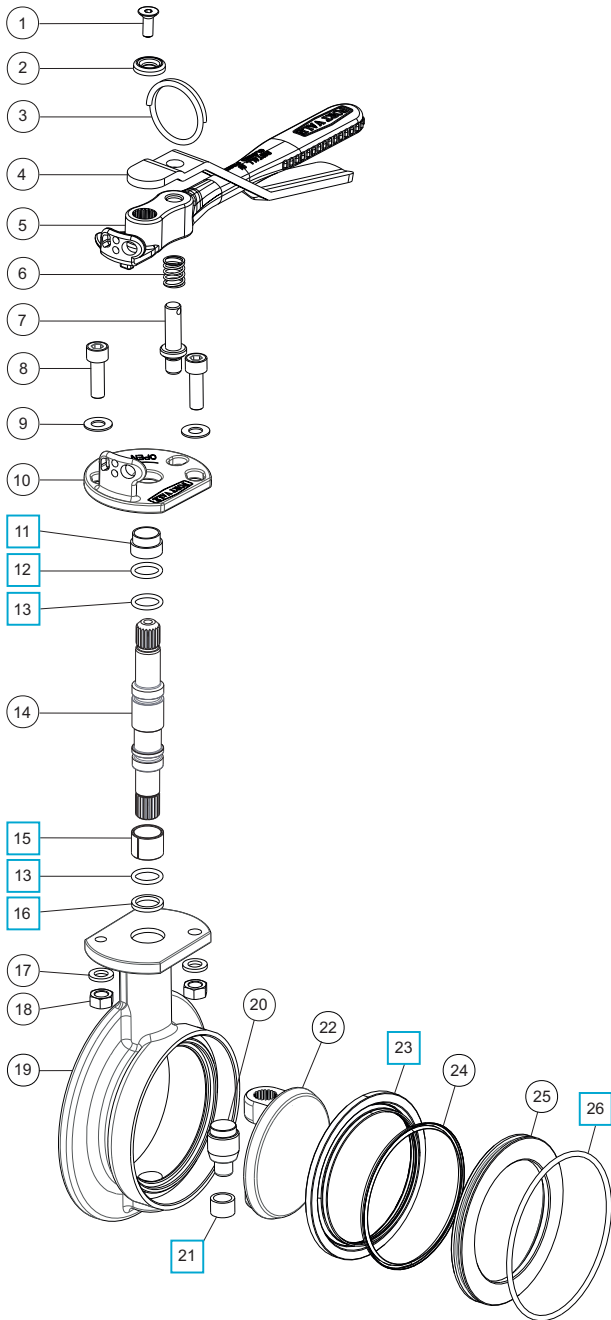

## Parts List

Item	Description	Part No.	
1	M6 set screw	5111-030	
2	Washer	20370	
3	Split ring	368/0011	
4	Operating lever	368/9837	
5	Handle	368/0050	
6	Handle location spring	368/0012	
7	Handle location pin	368/0010	
8	M8 cap screw (2)	5111-148	
9	M8 plain washer (2)	5113-005	
10	Stuffing clamp	368/0040	
11	PTFE stuffing clamp bush	368/0301	<input type="checkbox"/>
12	RTFE O ring	20363HT	<input type="checkbox"/>
13	Perfluoroelastomer O ring (2)	5005-586	<input type="checkbox"/>
14	Spindle	368/0205	
15	RTFE spindle bearing	368/0039	<input type="checkbox"/>
16	RTFE spindle seat	368/0009HT/1	<input type="checkbox"/>
17	M8 spring washer (2)	5113-003	
18	M8 full nut (2)	5112-001	
19	Body	368/0150	
20	Bottom spindle	368/0038	
21	RTFE bottom bush	368/0037	<input type="checkbox"/>
22	Closure plate	368/0400	
23	RTFE main seal	368/0002HT/5	<input type="checkbox"/>
24	Seal spring	368/0031	
25	Seal clamp plate	368/0033	
26	Silicone O ring	5005-342S	<input type="checkbox"/>

## Seal Kit

Description	Part No.
All parts marked <input type="checkbox"/> in the Parts List	368/71SKB



# Bottom Discharge Assembly

## Installation Options

### Example: 3" 3-Closure Bottom Discharge Assembly

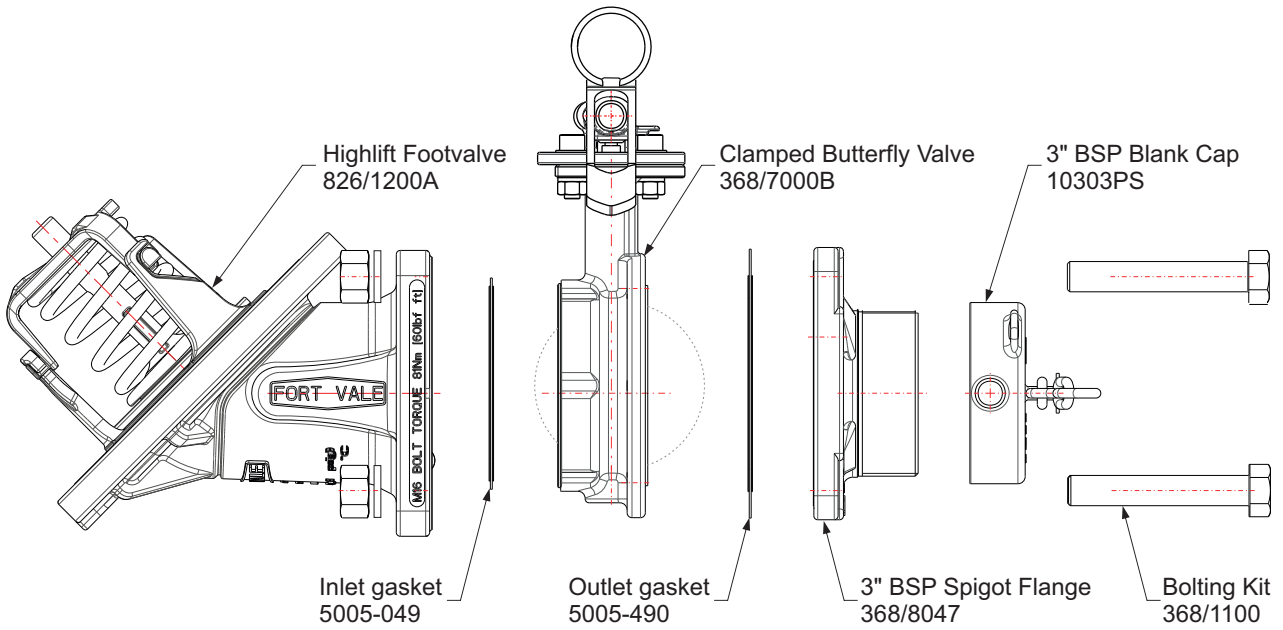





# Discharge Ball Valves

## Design Options

### Function

A discharge ball valve is used to load and discharge cargo. It is usually a secondary closure valve that is installed onto a footvalve (primary closure valve) at the drain point of a tank. A ball valve can also be used as a primary closure valve on the top of a tank.

### Design Options

The design options below are available on our standard range of discharge ball valves.

#### Nominal Bore

- 50mm (2")
- 80mm (3")
- 100mm (4")

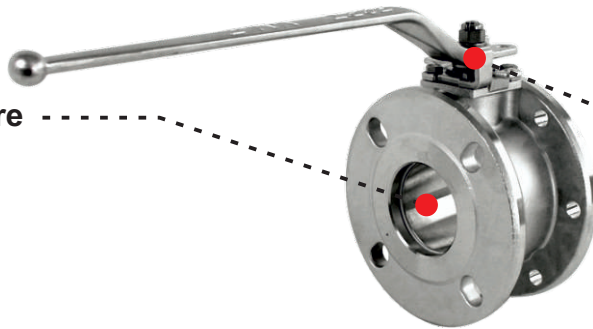

#### Operation

- Manually operated: A range of handles is available
- Left hand, right hand, ambidextrous
- Pneumatically actuated

#### Inlet Flange

- 4, 6 and 8 holes/slots drilling patterns
- Flats milled top and bottom

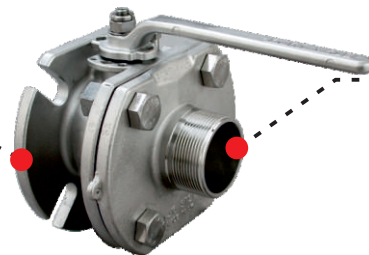

#### Outlet

- Threaded spigot flange
- Flush fit
- Bobbin flange with a range of drilling patterns
- Flats milled top and bottom
- Camlock

#### Valve Materials

- 316 stainless steel
- Special service conditions:**
- High nickel alloys
- Lined wetted parts, e.g. PFA



#### Finish

- Electropolished
- Special service conditions:**
- Corrosion-resistant paint on external surfaces to prevent damage from corrosive cargo vapour/splash

#### Special Cargoes

- For solidifying cargo:**
- Valve body with steam-heating chamber

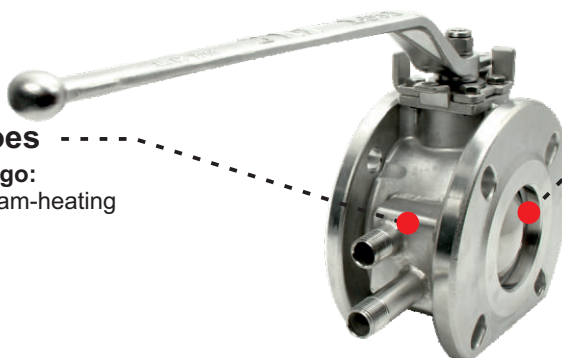

#### Main Seal

- PTFE
- Special service conditions:**
- High-temperature compatible seals



## Discharge Ball Valves

### Design Options

---

### Related Parts

We recommend our range of compatible accessories:

- Flanges - mating, adapter, blind, weld-in, syphon
- Tertiary closures
- Fasteners
- Gaskets

Please contact us for more information about these parts.

### Discharge Ball Valves for Dedicated Service

We offer a range of discharge ball valves suitable for these service conditions and special cargoes:

- T50 tank containers for liquefied gas
- Rail wagons
- Hydrogen peroxide
- Firesafe/lethal service

Please contact us for more information about these valves.



# DN40 Ball Valve with Inlet Seal Clamp

Part No: 370/2160X/XX



## Specification

### Nominal size

DN40

### Tank connection

Flanged: a selection is available - Refer to Table 2 on the next page

### Outlet/process connection

Flanged: a selection is available - Refer to Table 3 on the next page

### Options

Left or right hand operation

### Materials

Contact parts: 316 stainless steel

Main seal: PTFE

Alternatives are available, refer to the Design Options page

## Design Conditions

Weight:	4.75 Kg
Design Pressure (MAWP):	11 Bar
Test Pressure:	20.2 Bar
Design Temperature Min:	-40°C
Design Temperature Max:	205°C

**NOTE:** The Design Conditions and Section View dimensions are for the specified part number only.

### Design Codes

BS EN 14432

## Range

Description	Part No.
Left hand operated *Note	370/2160L/XX
Right hand operated *Note	370/2160R/XX

**NOTE:** The specification changes the Part No. Refer to the next page

## Related Parts

Please refer to Fort Vale for Related Parts.

## Section View

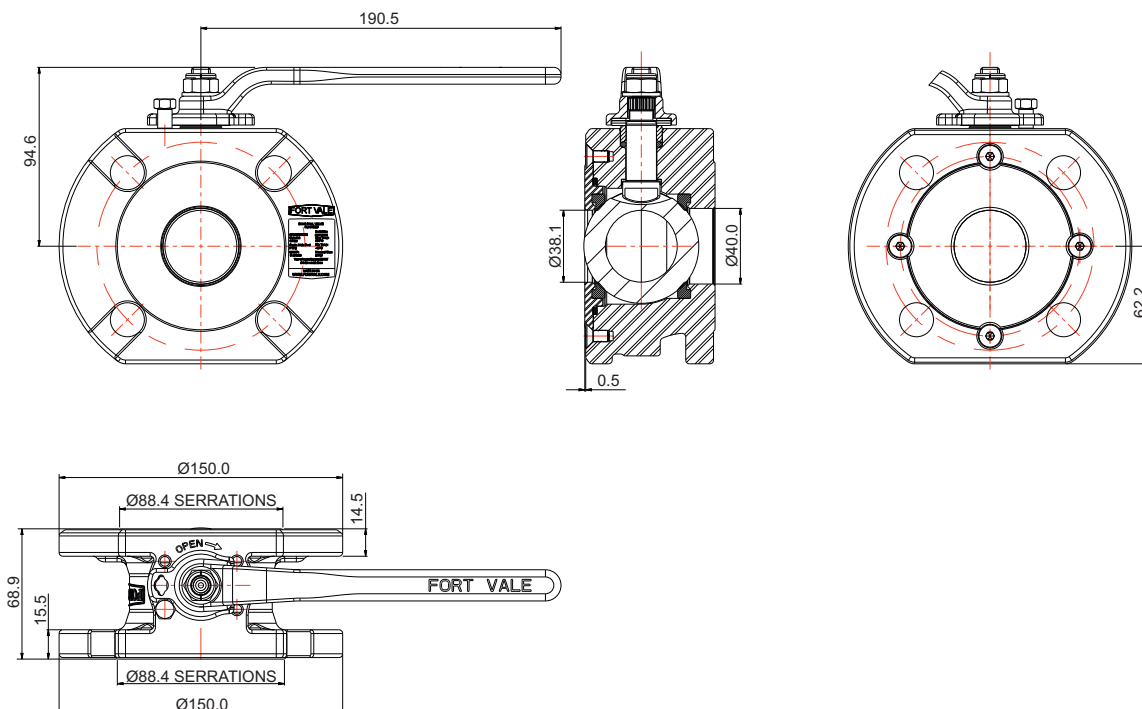



# DN40 Ball Valve with Inlet Seal Clamp

Part No: 370/2160X/XX

## Part Number Code: 370/2160X / X X

### Valve Operation

Refer to Table 1

### Inlet Flange Drilling

Refer to Table 2

### Outlet Flange Drilling

Refer to Table 3

**Table 1: Valve Operation**

Description	Part No.
Left hand operated	370/2160L/XX
Right hand operated	370/2160R/XX

**Table 2: Inlet Flange Drilling**

Inlet Holes	Hole Ø (mm)	Hole PCD (mm)	Code
4 holes	18	110.0	A
4 slots	18 wide	110.0 to 125.0	B
4 holes	18	110.0	C

Refer to Figure 1 on the next page for more information.

**Table 3: Outlet Flange Drilling**

Outlet Holes	Hole Ø (mm)	Hole PCD (mm)	Code
4 open slots	18 wide	110.0 to O/D	A
4 holes	M16	110.0	B
4 slots	18 wide	98.5 to 125.0	C
4 holes	M16	110.0	D
4 slots	18 wide	110.0 to 125.0	E
4 holes	18	110.0	F
4 slots	17 wide	98.5 to 110.0	G
4 holes and 4 slots	M16 18 wide	110.0 98.5 to 125.0	H

Refer to Figure 1 on the next page for more information.





# DN40 Ball Valve with Inlet Seal Clamp

Part No: 370/2160X/XX

**Figure 1**

Uncontrolled Copy of Drawing 370/2160X/XX - Inlet/Outlet Flange Information

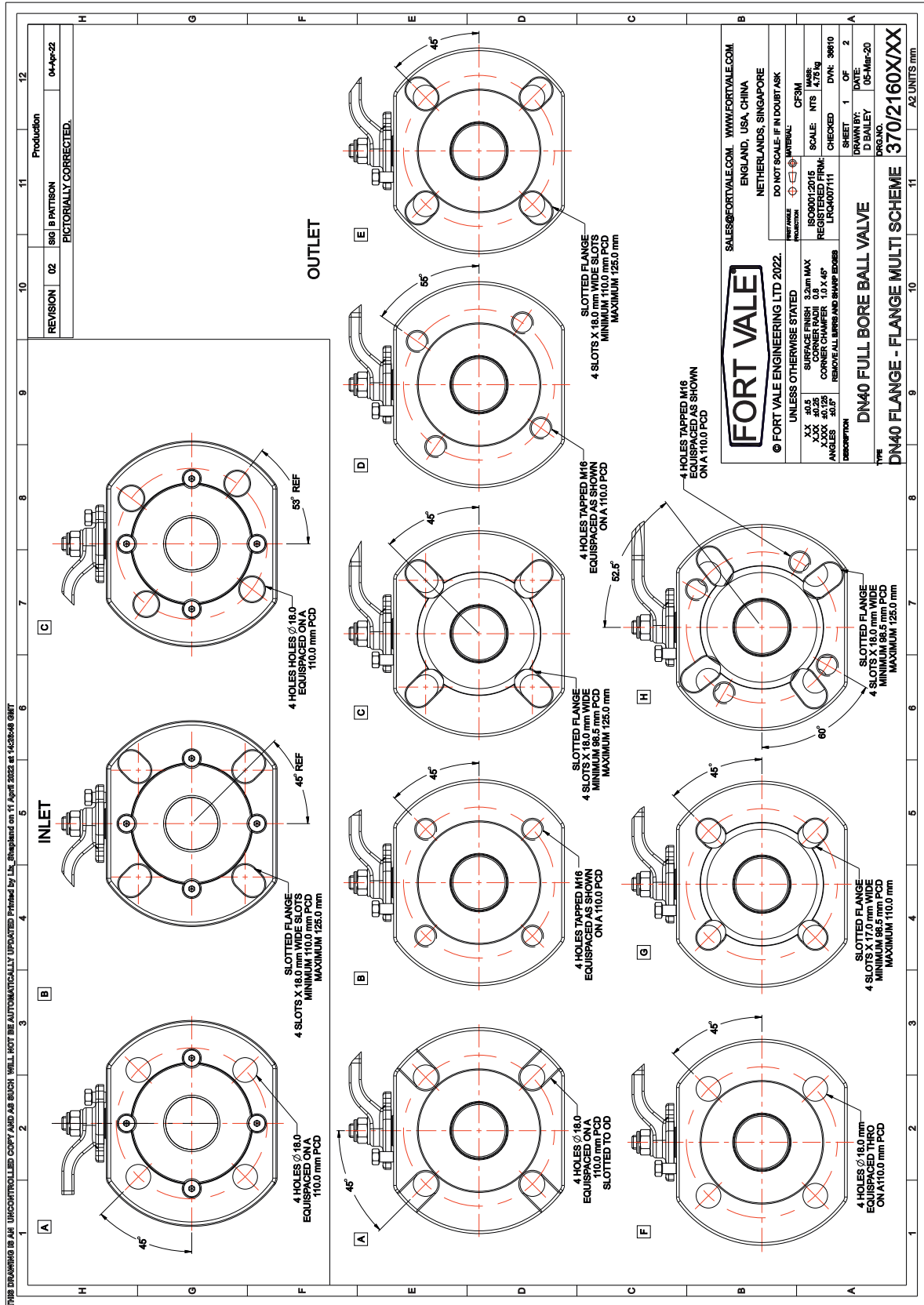



# DN40 Ball Valve with Inlet Seal Clamp

Part No: 370/2160X/XX

## Parts Drawing

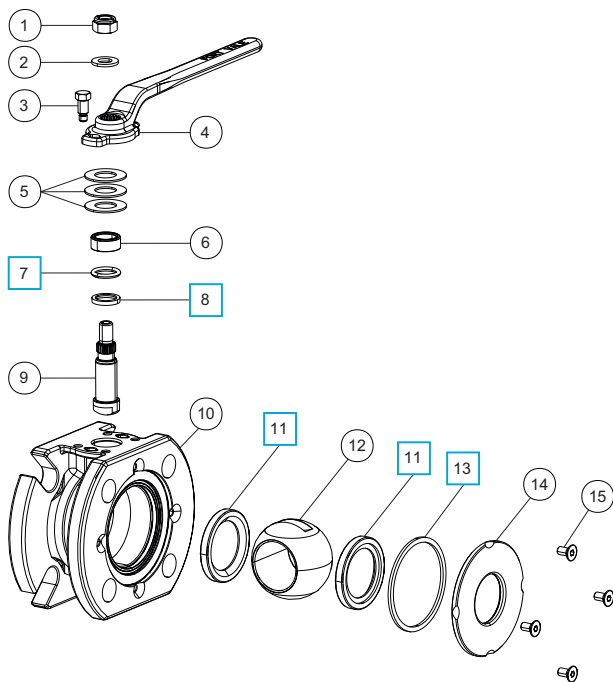

## Parts List

Item	Description	Part No.
1	M10 self-lock nut	5112-008
2	M10 washer	5113-009
3	Stop pin	370/0107
4	Handle	370/0125
5	Belleville washer (3)	5113-038
6	Stuffing collar	370/0103
7	PTFE O ring	5005-688 <input type="checkbox"/>
8	Bottom bearing	370/0104 <input type="checkbox"/>
9	Spindle	370/2112
10	Body *Note	370/2101XX
11	PTFE main seal (2)	370/2102 <input type="checkbox"/>
12	Ball	370/2104
13	Body seal	370/2109 <input type="checkbox"/>
14	Seal carrier clamp	370/2161
15	6mm countersunk bolt (4)	5111-018

**NOTE:** The specification changes the Part No.

## Seal Kit

Description	Part No.
All parts marked <input type="checkbox"/> in the Parts List	370/21SK



# DN50 Ball Valve with Inlet Seal Clamp

Part No: 370/0760X/XX



## Specification

### Nominal size

DN50

### Tank connection

Flanged: a selection is available - Refer to Table 2 on the next page

### Outlet/process connection

Flanged: a selection is available - Refer to Table 3 on the next page

### Options

Left or right hand operation

### Materials

Contact parts: 316 stainless steel

Main seal: PTFE

Alternatives are available, refer to the Design Options page

## Design Conditions

Weight:	5.74 Kg
Design Pressure (MAWP):	11 Bar
Test Pressure:	20.2 Bar
Design Temperature Min:	-40°C
Design Temperature Max:	205°C

**NOTE:** The Design Conditions and Section View dimensions are for the specified part number only.

### Design Codes

BS EN 14432

## Range

Description	Part No.
Left hand operated	370/0760L/XX
Right hand operated	370/0760R/XX

**NOTE:** The specification changes the Part No. Refer to the next page

## Related Parts

Please refer to Fort Vale for Related Parts.

## Section View

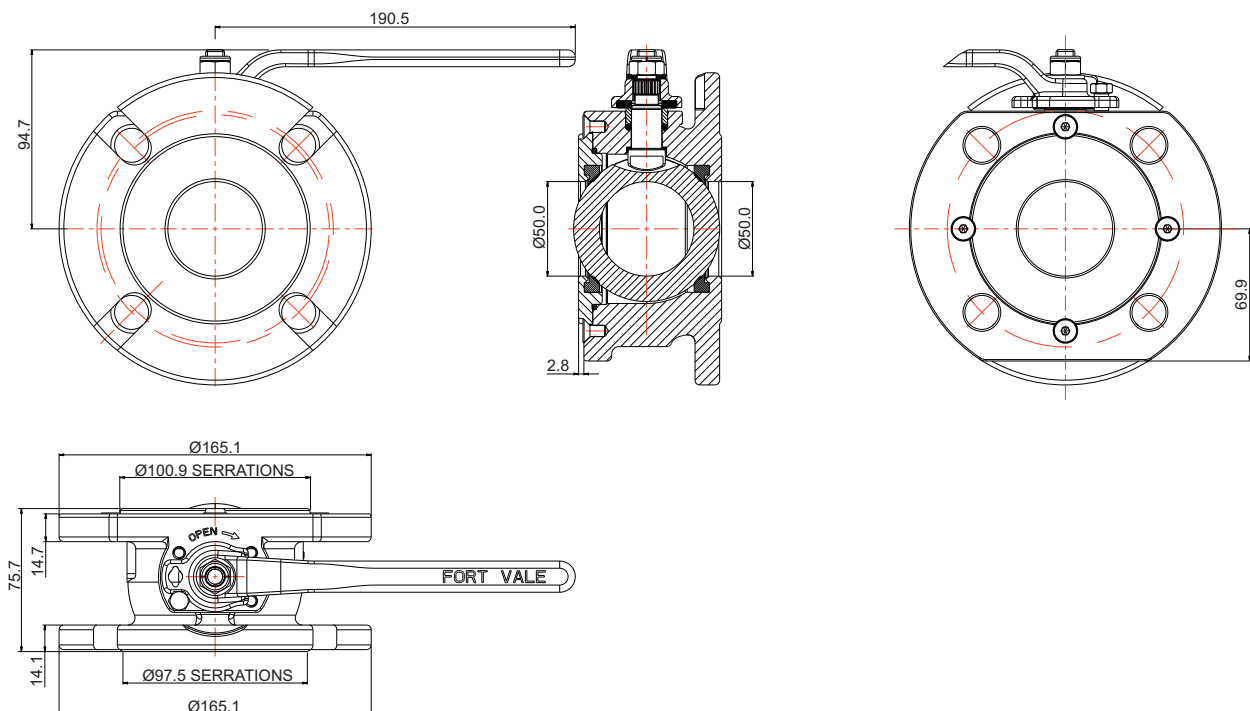



# DN50 Ball Valve with Inlet Seal Clamp

Part No: 370/0760X/XX

## Part Number Code: 370/0760X / X X

### Valve Operation

Refer to Table 1

### Inlet Flange Drilling

Refer to Table 2

### Outlet Flange Drilling

Refer to Table 3

**Table 1: Valve Operation**

Description	Part No.
Left hand operated	370/0760L/XX
Right hand operated	370/0760R/XX

**Table 2: Inlet Flange Drilling**

Inlet Holes	Hole Ø (mm)	Hole PCD (mm)	Code
4 holes	18	125.0	A
4 slots	17.8 wide	120.7 to 125.0	B

Refer to Figure 1 on the next page for more information.

**Table 3: Outlet Flange Drilling**

Outlet Holes	Hole Ø (mm)	Hole PCD (mm)	Code
4 open slots	17.8 wide	120.7 to O/D	A
4 open slots	17.8 wide	114.3 to O/D	B
4 holes	18	125.0	C
4 holes	M16	125.0	D
4 holes	M16	120.7	E
4 holes	M16	120.7	F
4 holes	M16	120.7	G
4 holes and 4 slots	M16	125.0	H
4 slots	17.5 wide	120.4 to 125.0	
4 slots	17.5 wide	120.4 to 125.0	I

Refer to Figure 1 on the next page for more information.



# DN50 Ball Valve with Inlet Seal Clamp

Part No: 370/0760X/XX

Figure 1

Uncontrolled Copy of Drawing 370/0760X/XX - Inlet/Outlet Flange Information

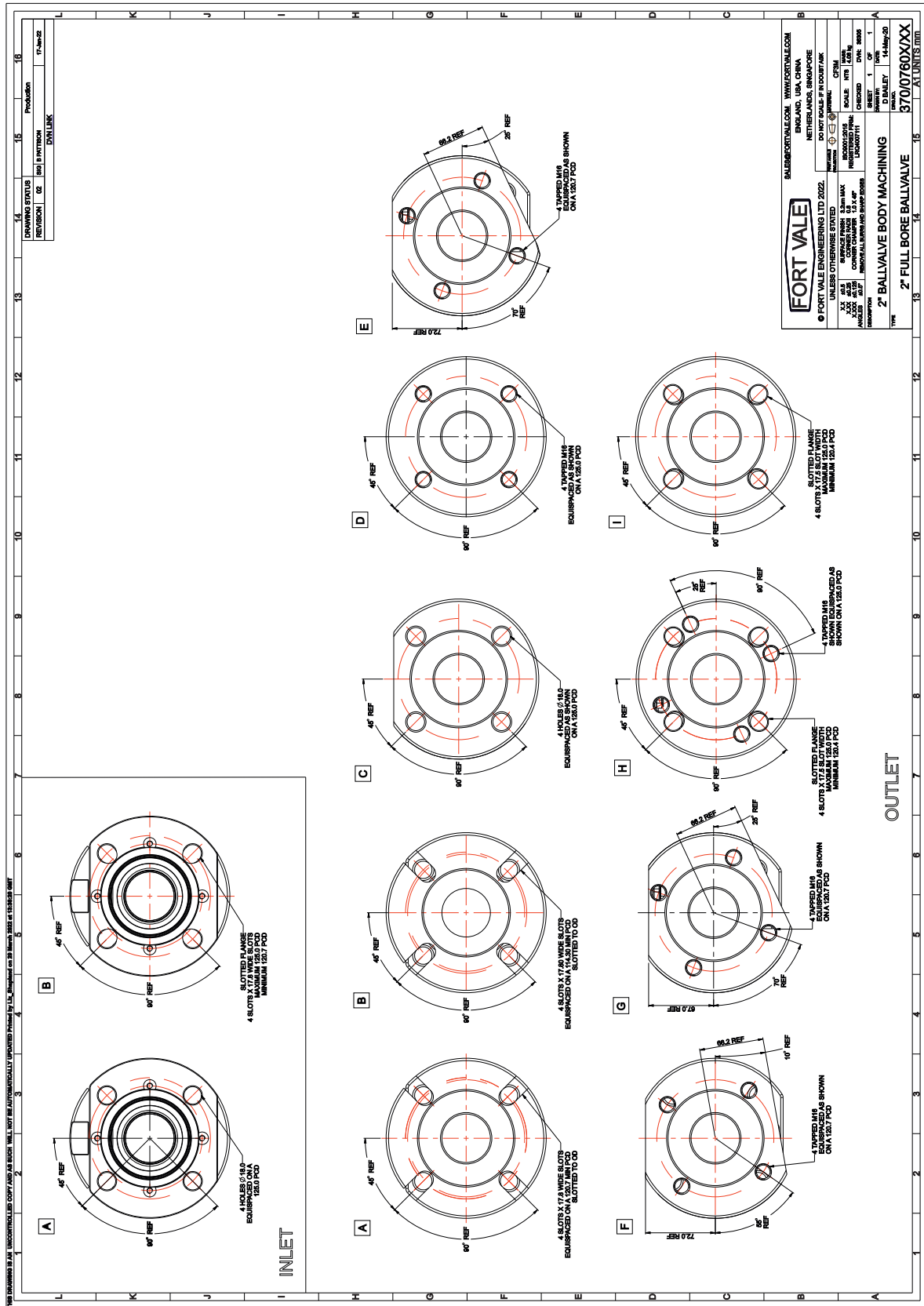



# DN50 Ball Valve with Inlet Seal Clamp

Part No: 370/0760X/XX

## Parts Drawing

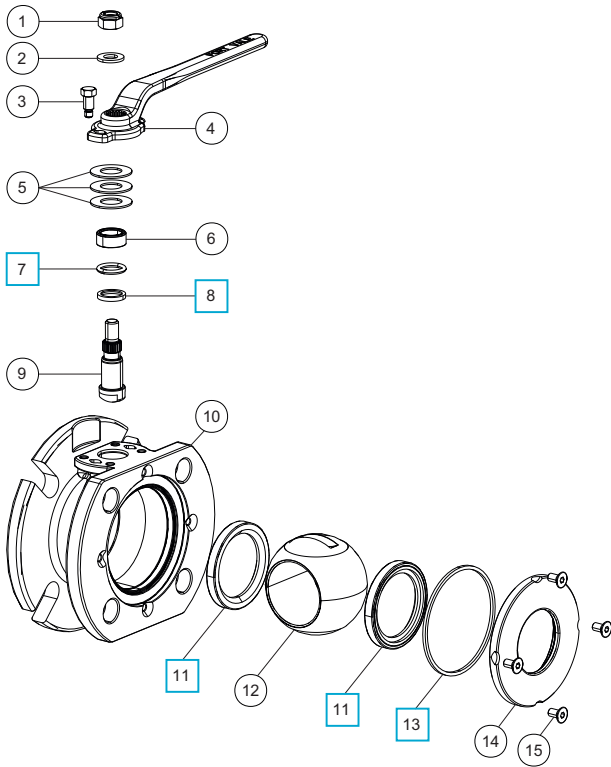

## Parts List

Item	Description	Part No.
1	M10 self-lock nut	5112-008
2	M10 washer	5113-009
3	Stop pin	370/0107
4	Handle	370/0125
5	Belleville washer (3)	5113-038
6	Stuffing collar	370/0103
7	PTFE O ring	5005-688 <input type="checkbox"/>
8	Bottom bearing	370/0104 <input type="checkbox"/>
9	Spindle	370/0120
10	Body *Note	370/N761XX
11	PTFE main seal (2)	370/0102 <input type="checkbox"/>
12	Ball	370/3301
13	Body seal	370/0106 <input type="checkbox"/>
14	Seal carrier clamp	370/0762
15	6mm countersunk bolt (4)	5111-018

**NOTE:** The specification changes the Part No.

## Seal Kit

Description	Part No.
All parts marked <input type="checkbox"/> in the Parts List	370/015SK



# DN80 Ball Valve with Inlet Seal Clamp

Part No: 360/6100X/XX



## Specification

### Nominal size

DN80

### Tank connection

Flanged: a selection is available - Refer to Table 2 on the next page

### Outlet/process connection

Flanged: a selection is available - Refer to Table 3 on the next page

### Options

Left or right hand operation

### Materials

Contact parts: 316 stainless steel

Main seal: PTFE

Part No. 360/6100X/BB shown

Alternatives are available, refer to the Design Options page

## Design Conditions

Weight:	13.6 Kg
Design Pressure (MAWP):	7 Bar
Test Pressure:	12.9 Bar
Design Temperature Min:	-40°C
Design Temperature Max:	200°C

**NOTE:** The Design Conditions and Section View dimensions are for the specified part number only.

### Design Code

BS EN 14432

## Range

Description	Part No.
Left hand operated *Note	360/6100L/XX
Right hand operated *Note	360/6100R/XX

**NOTE:** The specification changes the Part No. Refer to the next page

## Related Parts

Please refer to Fort Vale for Related Parts.

## Section View

Shown with no drilling

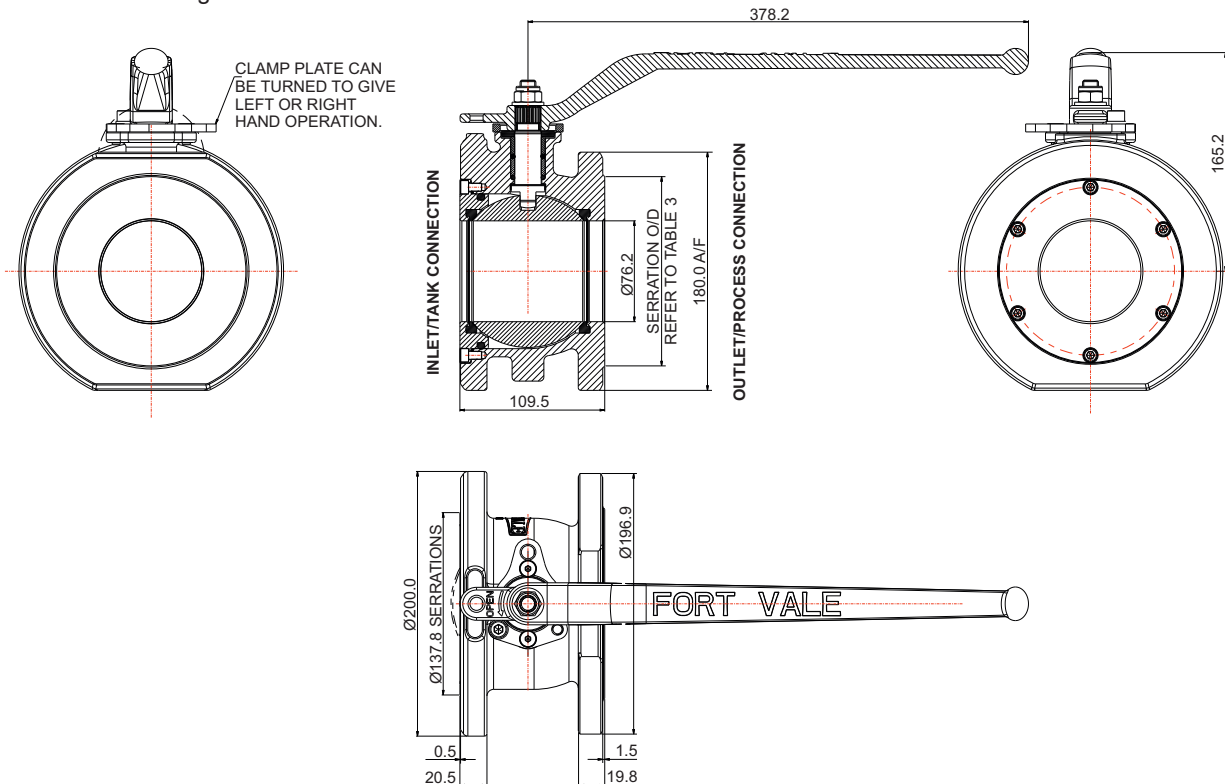



# DN80 Ball Valve with Inlet Seal Clamp

Part No: 360/6100X/XX

## Part Number Code: 360/6100X / X X

### Valve Operation

Refer to Table 1

### Inlet Flange Drilling

Refer to Table 2

### Outlet Flange Drilling

Refer to Table 3

**Table 1: Valve Operation**

Description	Part No.
Left hand operated	360/6100L/XX
Right hand operated	360/6100R/XX

**Table 2: Inlet Flange Drilling**

Inlet Holes	Hole Ø (mm)	Hole PCD (mm)	Code
0 holes	N/A	N/A	0
6 holes	14	168.3	A
8 holes	18	160.0	B
4 holes	17	160.0	C
8 slots	18 wide	159.0 to 168.0	D
4 holes and 6 holes	18 14	160.0 168.3	E

Refer to Figure 1 on the next page for more information.

**Table 3: Outlet Flange Drilling**

Outlet Holes	Hole Ø (mm)	Hole PCD (mm)	Serrations O/D (mm)	Code
0 holes	N/A	N/A	143.0	0
4 open slots	18 wide	160.0 to O/D	138.0	A
8 holes	18	160.0	138.0	B
8 slots	18 wide	152.4 to 160.0	130.0	C
4 holes and 4 holes	18 M16	160.0 160.0	143.0	D
4 slots	18 wide	146.0 to 160.0	127.0	E
4 holes and 4 holes	18 M16	160.0 160.0	143.0	F
8 holes and 4 holes	18 18	160.0 152.4	130.0	G
8 holes	M16	160.0	143.0	H
4 holes and 4 holes	18 18	160 152.4	127.0	I
4 slots and 4 holes	18 wide M16	146.0 to 160.0 160.0	127.0	J

Refer to Figure 1 on the next page for more information.





# DN80 Ball Valve with Inlet Seal Clamp

Part No: 360/6100X/XX

**Figure 1**

Uncontrolled Copy of Drawing 360/6100X/XX - Inlet/Outlet Flange Information

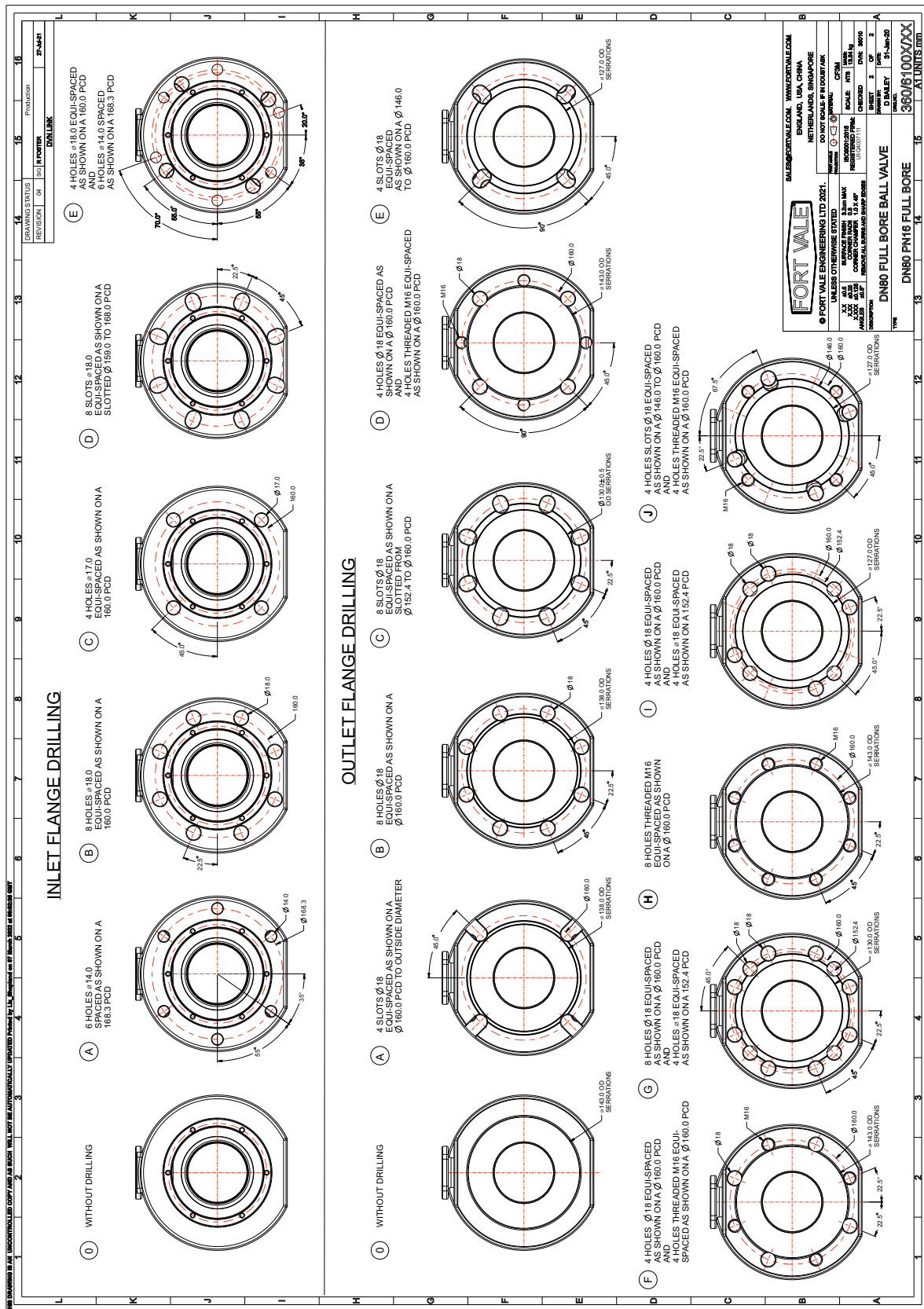



# DN80 Ball Valve with Inlet Seal Clamp

Part No: 360/6100X/XX

## Parts Drawing

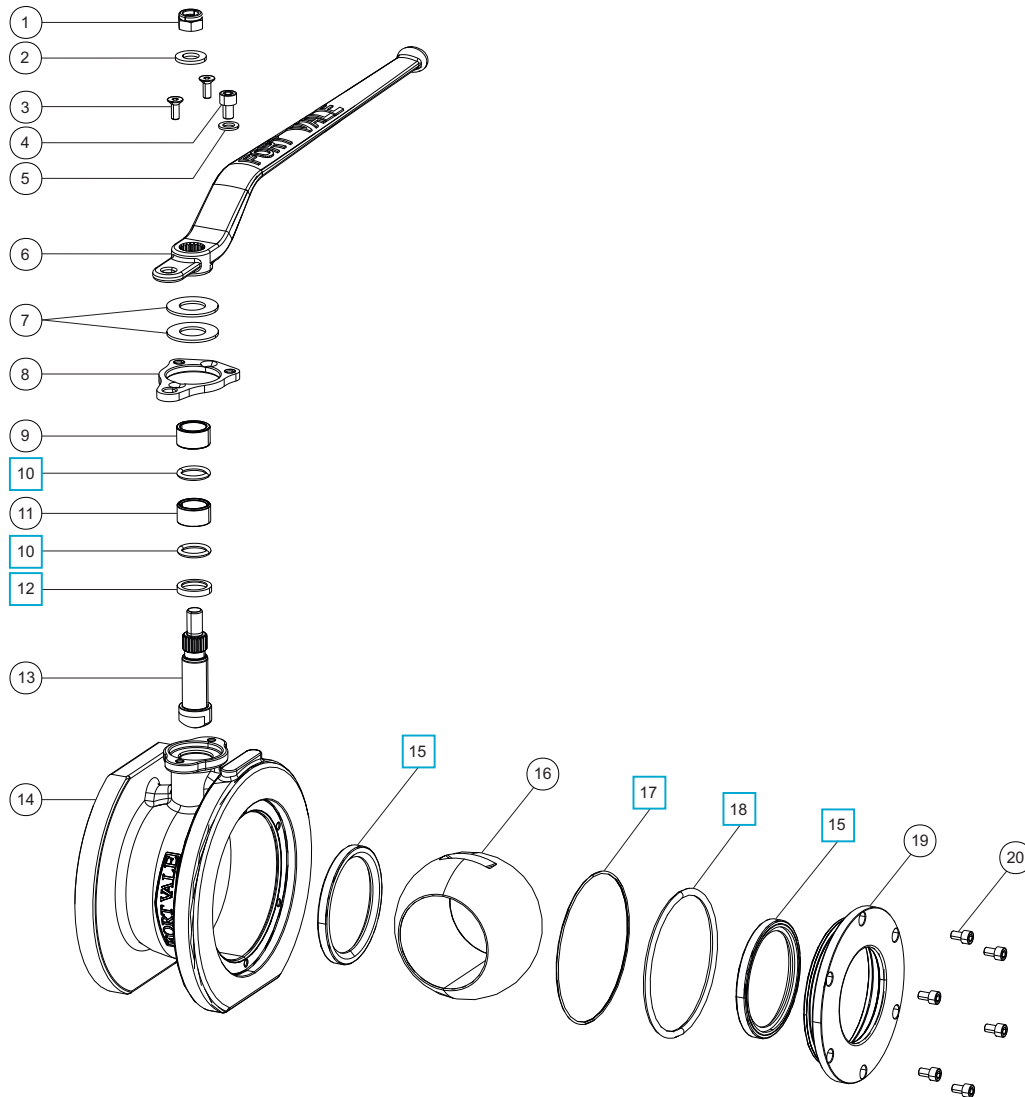

### Parts List

Item	Description	Part No.
1	M12 self-lock nut	5112-007
2	M12 washer	5123-003
3	M6 countersunk bolt (2)	5111-030
4	M8 cap screw	5111-215
5	M8 spring washer	5113-003
6	Handle	360/3416
7	Belleville washer (2)	5113-041
8	Stop plate	360/6111
9	Top stuffing collar	360/3412
10	PTFE O ring (2)	5005-113 <input type="checkbox"/>
11	Bottom stuffing collar	360/3413
12	Bottom bearing	360/3421 <input type="checkbox"/>
13	Spindle	360/3422
14	Body *Note	360/6110/XX
15	PTFE main seal (2)	360/3402 <input type="checkbox"/>
16	Ball	360/3401

### Parts List

Item	Description	Part No.
17	PTFE O ring	ORB544P0 <input type="checkbox"/>
18	Fortyt O ring	ORB347F0 <input type="checkbox"/>
19	Seal carrier clamp	360/6105
20	M6 cap screw (6)	5111-061

**NOTE:** The specification changes the Part No.

### Seal Kit

Description	Part No.
All parts marked <input type="checkbox"/> in the Parts List	360/61SK



# Top Discharge Provision

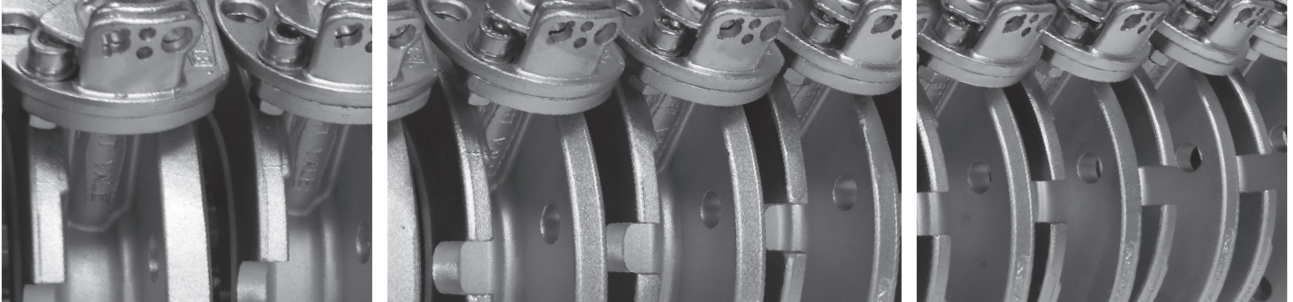





# 3" Flanged Widdop Butterfly Valve

Part No: 368/3160A

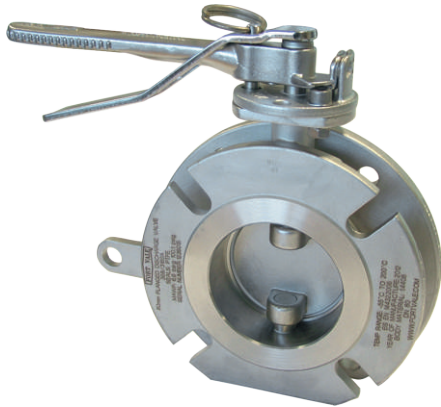

## Specification

### Nominal size

80mm

### Tank connection

Flanged: 6 x 14mm holes on a 168mm PCD

### Outlet/Process connection

Flanged: 4 x open slots on a 146mm minimum PCD

### Properties

Left hand operated, handle with TIR and padlock slots

### Materials

Contact parts: 316 stainless steel

Main seal: PTFE

Alternatives are available, refer to the Design Options page

## Design Conditions

Weight:	7.0 Kg
Design Pressure (MAWP):	6.9 Bar
Test Pressure:	12.6 Bar
Design Temperature Min:	-55°C
Design Temperature Max:	200°C

**NOTE:** The Design Conditions and Section View dimensions are for the specified part number only.

### Design Code

BS EN14432

### Design Approvals

Lloyds Register of Shipping  
Rijksdienst  
SNCF  
RMRS

## Range

Description	Part No.
Standard specification	368/3160A
Inlet flange dual drilled: 4 hole/4 hole	368/3180A
Inlet flange dual drilled: 6 hole/4 hole	368/3280A

## Related Parts

Description	Part No.
Tank weld-in flange	368/0800
CNAF/PTFE syphon tube inlet gasket	5005-222
Syphon tube	368/0810
Stud kit	312/1000
CNAF/PTFE inlet gasket	5005-169
Solid PTFE outlet gasket	5005-417
Dished blind flange	312/0022CM
Pivot pin for blind flange	368/7506

## Section View

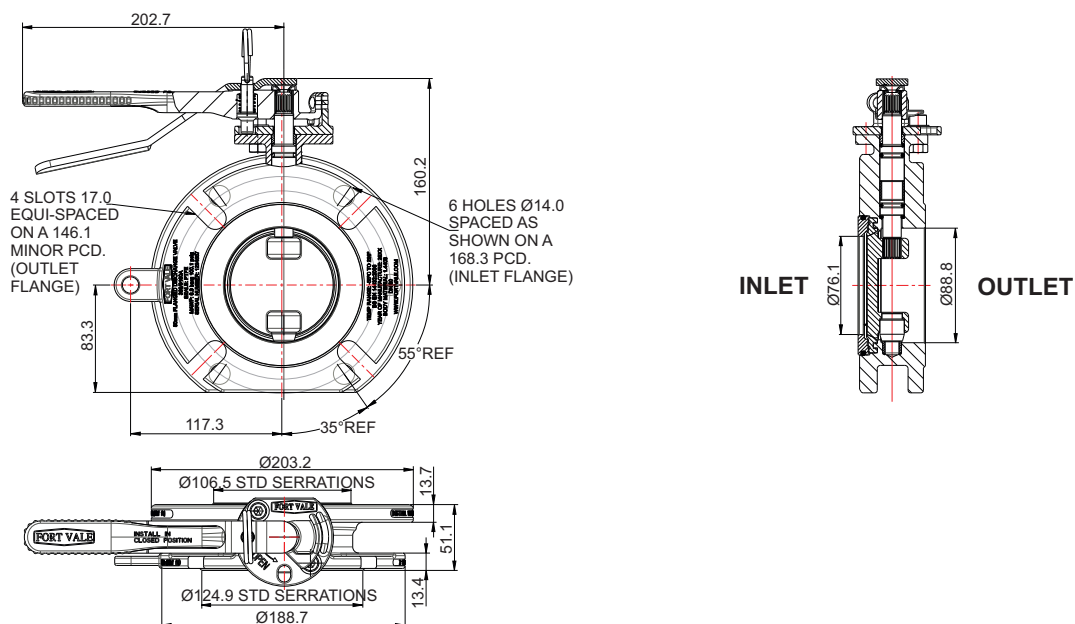



# 3" Flanged Widdop Butterfly Valve

Part No: 368/3160A

## Parts Drawing

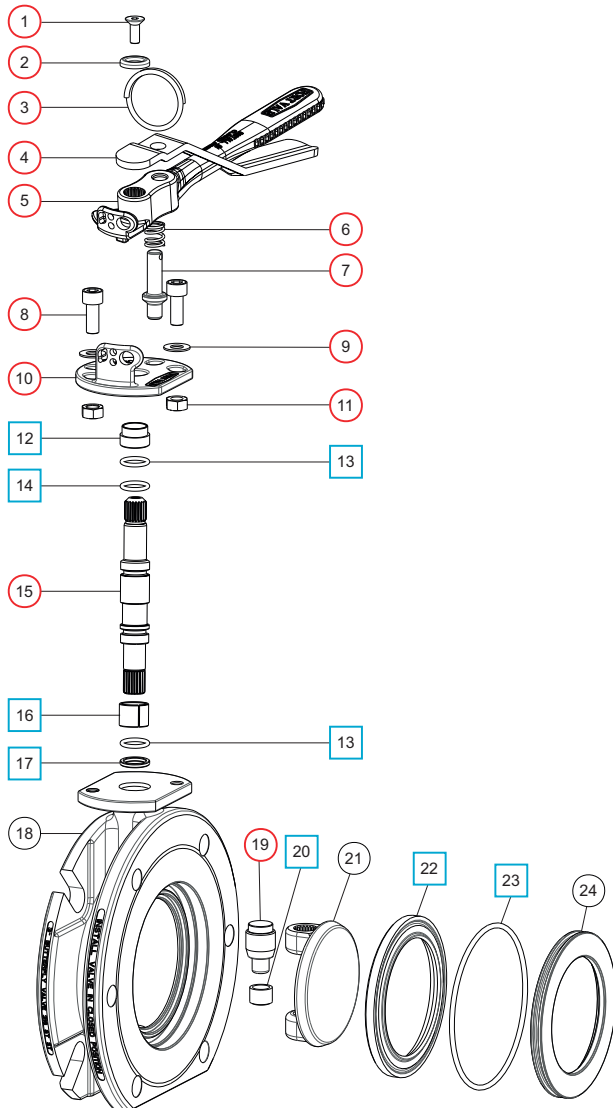

## Parts List

Item	Description	Part No.	
1	M6 set screw	5111-030	○
2	Washer	20370	○
3	Split ring	368/0011	○
4	Operating lever	368/9837	○
5	Handle	368/0050	○
6	Handle location spring	368/0012	○
7	Handle location pin	368/0010	○
8	M8 cap screw (2)	5111-255	○
9	M8 plain washer (2)	5113-005	○
10	Stuffing clamp	368/0040	○
11	M8 full nut (2)	5112-001	○
12	PTFE stuffing clamp bush	368/0301	□ ○
13	PTFE O ring (2)	20363	□ ○
14	Viton O ring	20361	□ ○
15	Spindle	368/0200	○
16	Split bearing	252/0517	□ ○
17	PTFE spindle seat	368/0009	□ ○
18	Body	368/9141	
19	Bottom spindle	368/0036	○
20	PTFE bottom bush	368/0035	□ ○
21	Closure plate	368/0400	
22	PTFE main seal	368/0002	□ ○
23	Nitrile O ring	5005-342	□ ○
24	Seal clamp plate	368/9148	

## Seal Kit

Description	Part No.
All parts marked □ in the Parts List	368/00SK

## Repair Kit

Description	Part No.
All parts marked ○ in the Parts List	368/316RKA



# 3" Flanged Widdop Butterfly Valve - Dual Drilled Inlet

Part No: 368/3280A



## Specification

### Nominal size

80mm

### Tank connection

Dual-drilled flange: 6 x 14mm holes on a 168.3mm PCD & 4 x 18mm holes on a 160mm PCD

### Outlet/Process connection

Flanged: 4 x open slots on a 146mm minimum PCD

### Properties

Left hand operated, handle with TIR and padlock slots

### Materials

Contact parts: 316 stainless steel

Main seal: PTFE

Alternatives are available, refer to the Design Options page

## Design Conditions

Weight:	6.9 Kg
Design Pressure (MAWP):	6.9 Bar
Test Pressure:	10.35 Bar
Design Temperature Min:	-40°C
Design Temperature Max:	200°C

**NOTE:** The Design Conditions and Section View dimensions are for the specified part number only.

### Design Code

BS EN14432

## Range

Description	Part No.
Inlet flange dual drilled: 6 hole/4 hole	368/3280A
Inlet flange dual drilled: 4 hole/4 hole	368/3180A
Inlet flange with flat, drilled 6 holes	368/3160A

## Related Parts

Description	Part No.
CNAF/PTFE dual drilled inlet gasket	5005-770
CNAF/PTFE 6 hole inlet gasket	5005-222
CNAF/PTFE 4 hole inlet gasket	5005-034
Solid PTFE outlet gasket	5005-417
Dished blind flange	312/0022CM
Pivot pin for blind flange	368/7506

## Section View

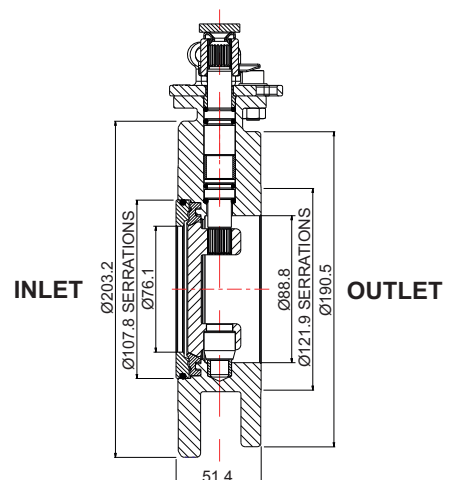
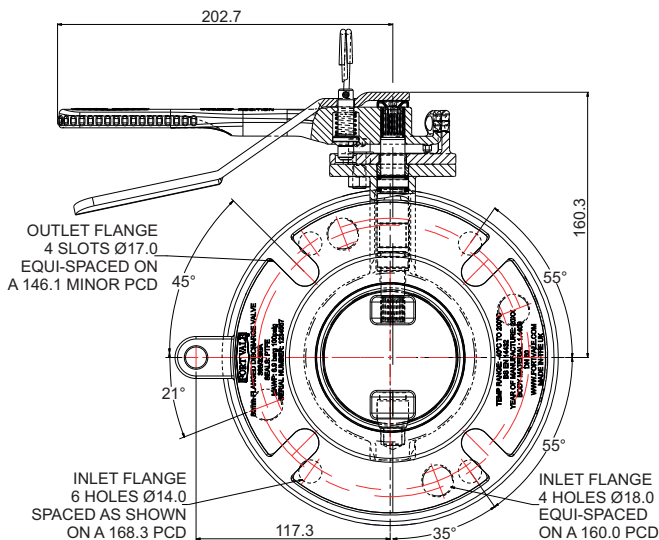



# 3" Flanged Widdop Butterfly Valve - Dual Drilled Inlet

Part No: 368/3280A

## Parts Drawing

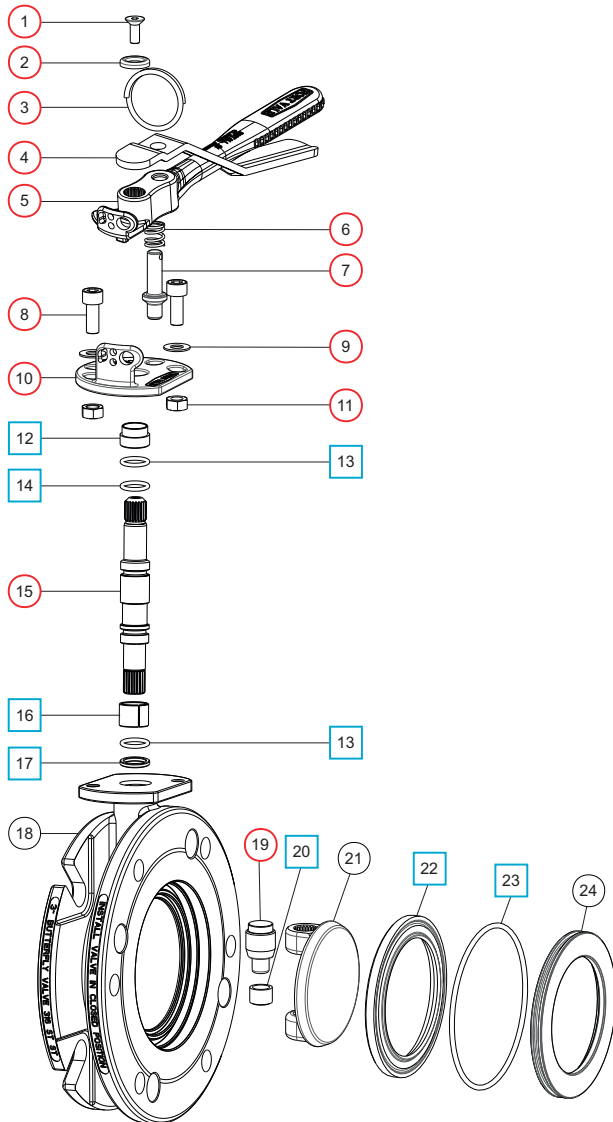

## Parts List

Item	Description	Part No.	
1	M6 set screw	5111-030	○
2	Washer	20370	○
3	Split ring	368/0011	○
4	Operating lever	368/9837	○
5	Handle	368/0050	○
6	Handle location spring	368/0012	○
7	Handle location pin	368/0010	○
8	M8 cap screw (2)	5111-255	○
9	M8 plain washer (2)	5113-005	○
10	Stuffing clamp	368/0040	○
11	M8 full nut (2)	5112-001	○
12	PTFE stuffing clamp bush	368/0301	□ ○
13	PTFE O ring (2)	20363	□ ○
14	Viton O ring	20361	□ ○
15	Spindle	368/0200	○
16	Split bearing	252/0517	□ ○
17	PTFE spindle seat	368/0009	□ ○
18	Body	368/9192	
19	Bottom spindle	368/0036	○
20	PTFE bottom bush	368/0035	□ ○
21	Closure plate	368/0400	
22	PTFE main seal	368/0002	□ ○
23	Nitrile O ring	5005-342	□ ○
24	Seal clamp plate	368/9148	

## Seal Kit

Description	Part No.
All parts marked □ in the Parts List	368/00SK

## Repair Kit

Description	Part No.
All parts marked ○ in the Parts List	368/316RKA





## Butterfly Valve Top Discharge Assembly Installation Options

### Example: 3" Flanged Butterfly Valve Top Discharge Assembly

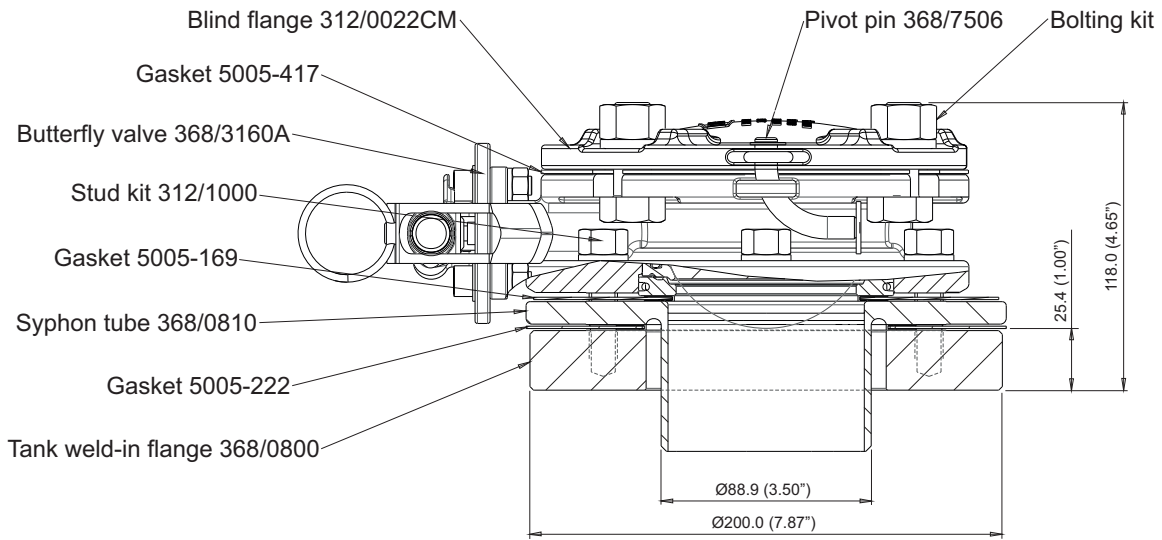



# Accessories

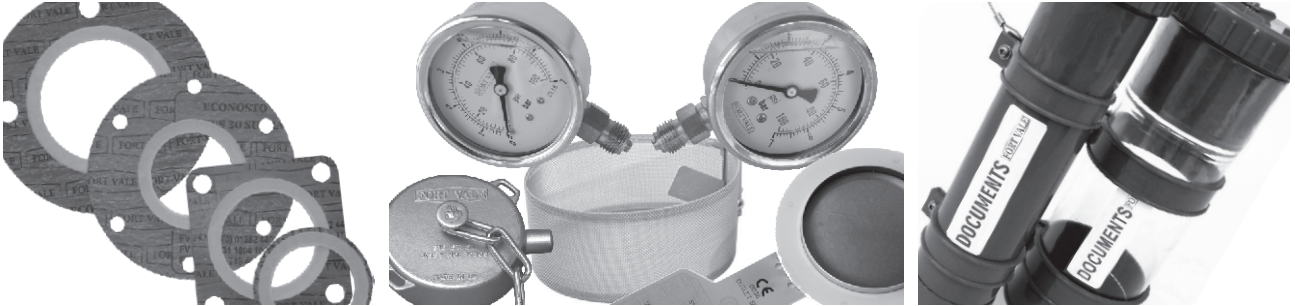





# 3/4" BSPT Steam Tell-Tale Valve

Part No: 56/0XXX0



## Specification

**Nominal size**

DN20

**Tank connection**

3/4" BSPT (taper)

**Set pressure**

From 3 PSI to 150 PSI (0.21 Bar to 10.34 Bar)

**Materials**

Contact parts: 316 stainless steel

Pressure O ring: Viton

Alternatives are available, refer to Range

## Design Conditions

Weight: 0.1 Kg  
 Design Pressure (MAWP): 10.3 Bar  
 Design Temperature Max: 200°C

**NOTE:** The Design Conditions and Section View dimensions are for the specified part number only.

## Range

Description	Part No.
Standard specification	56/0XXX0
With TIR tab on valve body	56/0XXX0T
3/4" NPTM connection	52/0XXX0

**NOTE:** The pressure setting changes the Part No.

## Section View

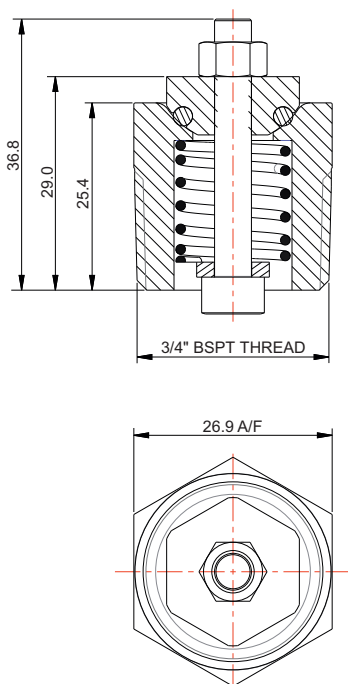



# 3/4" BSPT Steam Tell-Tale Valve

Part No: 56/0XXX0

## Parts Drawing

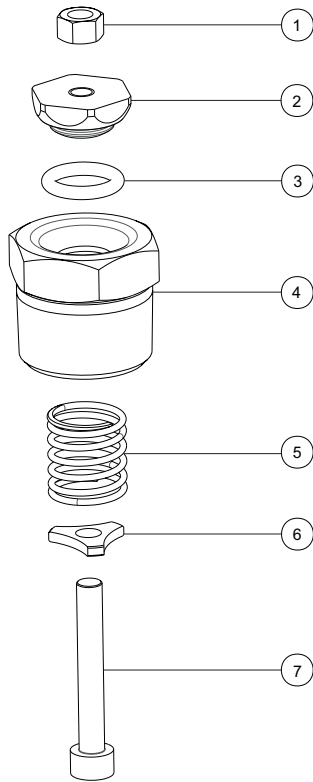

## Parts List

Item	Description	Part No.
1	M5 nut	5112-010
2	Poppet head	54/00003
3	Viton O ring	5005-650
4	Body	54/00001
5	Spring *Note	5104-XXXXA
6	Spring locator	54/00002
7	M5 cap screw	5111-128

**NOTE:** The pressure setting changes the Part No.



# 3/4" BSPT Steam Relief Valve

Part No: 58/0XXX00



## Specification

**Nominal size**

DN20

**Tank connection**

3/4" BSPT (taper)

**Set pressure**

From 5 PSI to 225 PSI (0.34 Bar to 15.52 Bar)

**Materials**

Contact parts: 316 stainless steel

Pressure O ring: Viton GFLT

Alternatives are available, refer to Range

## Design Conditions

Weight:	0.6 Kg
Design Pressure (MAWP):	16.5 Bar
Design Temperature Min:	-40°C
Design Temperature Max:	200°C

**NOTE:** The minimum re-seal temperature is -25°C.  
The Design Conditions and Section View dimensions are for the specified part number only.

## Range

Description	Part No.
Standard specification	58/0XXX00

**NOTE:** The pressure setting changes the Part No.

## Section View

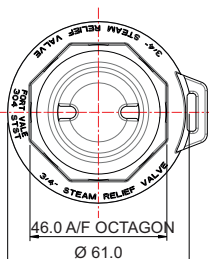
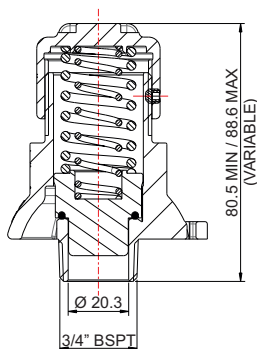



## 3/4" BSPT Steam Relief Valve

Part No: 58/0XXX00

### Parts Drawing

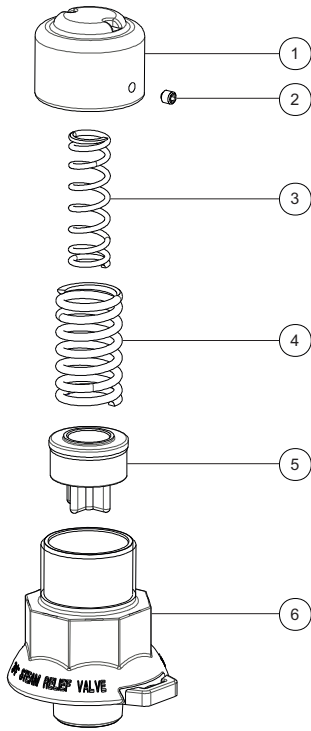

### Parts List

Item	Description	Part No.
1	Cap	58/03650
2	Set screw	5121-001
3	Inner spring *Note	5104-90XX
4	Outer spring *Note	5104-9XXX
5	Poppet assembly with Viton GFLT seal *Note	58/0362X
6	Body	58/03640

**NOTE:** The pressure setting changes the Part No.





## Threaded Blank Caps Accessories & Spare Parts



### Specification

Caps are supplied with a washer and a security wire or heavy duty chain as standard.

#### Nominal sizes

From 1/2" to 4"

#### Thread options

BSP, NPT, NPSL

#### Material options

Cap: stainless steel, aluminium

Washer: PTFE, leather

**If the type you need is not shown, please contact us.**

### Stainless Steel Caps - BSP Thread

Supplied as standard with a PTFE washer and a stainless steel chain or wire to prevent loss/theft.

Size	Wire or Chain	Part No.
1/2" BSP	Wire	10316PS
3/4" BSP	Chain	10306PS
1" BSP	Chain	10305PS
1 1/2" BSP	Chain	10300PS
2" BSP	Chain	10301PS
2 1/2" BSP	Wire	10302PS
3" BSP	Chain	10303PS
4" BSP	Wire	10304PSC

### Spare Parts - Washers

Description	Part No. Leather	Part No. PTFE
1/2" washer	-	10335P
3/4" washer	10331L	10331P
1" washer	10319L	10319P
1 1/2" washer	10326L	10326P
2" washer	10327L	10327P
2 1/2" washer	10328L	10328P
3" washer	10329L	10329P

### NPT & NPSL Caps

Supplied as standard with a washer and a chain to prevent loss/theft.

Size	Cap	Washer	Chain	Part No.
1 1/2" NPT	st/st	PTFE	st/st	10300NPTP
2" NPT	st/st	PTFE	st/st	10301NPTP
3" NPSL	st/st	PTFE	st/st	425/3240
3" NPT	aluminium	leather	brass	10711NPT

### Aluminium Caps - BSP Thread

Supplied as standard with a leather washer and a brass chain to prevent loss/theft.

Size	Part No.
3/4" BSP	10706AL
1" BSP	10707AL
1 1/2" BSP	10708AL
2" BSP	10709AL
2 1/2" BSP	10710AL
3" BSP	10711AL



## Burst Discs

### Accessories & Spare Parts

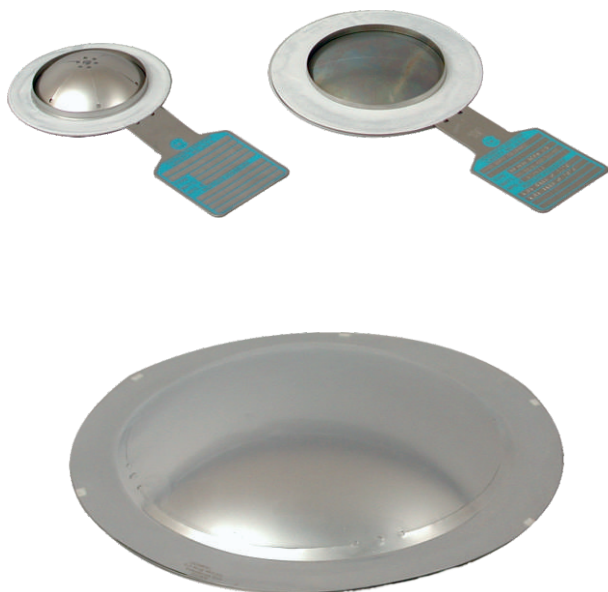

### Specification

Our range of non-fragmenting burst discs is compatible with Fort Vale relief valves and accessories. If you have other manufacturer's equipment, please contact us.

**WARNING:** A burst disc decreases the air flow capacity of a relief valve. Calculate to make sure that the decreased flow will give sufficient protection to your tank/system. Refer to Fort Vale for more information.

#### Nominal sizes

65mm XL, 80mm XL, 89mm, 250mm

Other sizes are available, please contact us.

**NOTE:** 65mm XL/80mm XL discs replace the original 65mm/80mm discs. We do not recommend 65mm/80mm discs with Fort Vale relief valves.

#### Disc options

Forward Acting: a cross-scored solid metal disc

Forward Composite: a multi-layered disc for burst settings of less than 3.67 Bar

Reverse Acting: compatible with gas service

#### Materials

65XL/80XL/89mm: PTFE/316 stainless steel/Nickel

250mm: PTFE/316 stainless steel

Other materials are available, refer to next page.

### 65mm XL Burst Discs

Compatible with general purpose tank containers and road tankers.

Burst Pressure Bar	Burst Temperature °C	Part No.
2.28	20	862/X0228020B
2.41	20	862/X0241020B
2.69	20	862/X0269020B
3.10	20	862/X0310020B
3.67	20	862/X0367020A
4.10	20	862/X0410020A
4.40	20	862/X0440020A
4.84	20	862/X0484020A

**NOTE:** The specification changes the part no.

### 80mm XL Burst Discs

Compatible with general purpose tank containers and road tankers.

Burst Pressure Bar	Burst Temperature °C	Part No.
3.67	20	864/X0367020A
4.10	20	864/X0410020A
4.84	20	864/X0484020A

**NOTE:** The specification changes the part no.

### 89mm Reverse Acting Burst Discs

Compatible with compressed liquefied gas tank containers.

Burst Pressure Bar	Burst Temperature °C	Part No.
12.10	55	864/X1210055GX
15.00	55	864/X1500055GX
22.00	55	864/X2200055GX
27.50	55	864/X2750055GX
34.50	55	864/X3450055GX

**NOTE:** The specification changes the part no.

### 250mm Standard Burst Discs

Compatible with hydrogen peroxide service.

Burst Pressure Bar	Burst Temperature °C	Part No.
4.50	20	865/A0450020AD
4.50	60	865/A0450060AD
6.00	20	865/A0600020AD



**Part Number Code: 65mm XL, 80mm XL, 89mm Only**  
**Accessories & Spare Parts**

Example: **8 6 X / X 0484 020 X X**

**Disc Size**

- 862/ 65mm XL
- 864/ 80mm XL or 89mm Reverse Acting

**Disc Manufacturer**

- A CDC (Continental Disc Corporation)
- B BS&B Safety Systems
- C Schlesinger

**Burst Pressure in kPa**

- 0484 484 kPa (4.84 Bar)

**Burst Temperature in °C**

- 020 20°C

**Disc Type**

- A Forward Acting (ICON)
- B Forward Composite (PC-SERT)
- G Reverse Acting: Gas service

**Special Material/Service: Disc Type A & B Only**

**Note:** No number = Standard Material/Service

- 1 PFA Lined
- 2 PTFE Lined
- 3 Tantalum
- 4 Alloy 600
- 5 Oxygen Cleaned
- 6 High Temperature 250°
- 7 Titanium
- 8 Standard 30° Angle
- 9 Monel ®
- A Inconel ® / 316TI
- B Nickel
- C Hastelloy ® C276
- D Standard + Handling Support
- E Monel ® Fluoro Coated

**Special Material/Service: Disc Type G Only**

**Note:** No number = Standard Material/Service

- 1 Hastelloy ® / PTFE
- 2 Monel ®
- 3 Tantalum
- 4 Alloy 400
- 5 Alloy 600
- 6 Monel ® 400 / Sigma ® 500



## Document Holders

### Accessories & Spare Parts



### Specification

**Nominal sizes**

75mm and 110mm

**Body material options**

Opaque plastic

Transparent plastic

**Fixing bracket options**

Plastic

Stainless steel

**Cap**

All document holders are supplied with a plastic cap as standard which is attached by a stainless steel wire to prevent loss/theft.

### Document Holders

Size	Body	Brackets	Part No.
75mm	Opaque	Plastic	360/1101
75mm	Transparent	Plastic	360/1101T
75mm	Opaque	St/steel	360/1101ABSS
75mm	Transparent	St/steel	360/1101TBSS
110mm	Transparent	Plastic	460/1101T
110mm	Transparent	St/steel	460/1101TBSS

### Spare Parts - Plastic Caps

All caps are supplied with a stainless steel cable.

Size	Part No.
75mm	360/1010
110mm	460/1010

### Spare Parts - Fixing Brackets

Size	Material	Part No.
75mm	Plastic	360/1007
75mm	Stainless steel	360/1007SS
110mm	Plastic	460/1007
110mm	Stainless steel	460/1007SS



# Fusible Link Assembly

Part No: 324/5760



## Specification

A fusible link assembly automatically closes a footvalve if there is a fire. The device is installed onto the tank frame and attaches to the footvalve remote closure cable. The fusible element will melt at 100°C. This makes the spring-loaded chain operate the remote closure cable to close the footvalve.

### Compatibility

All tank designs and most types of footvalve

### Material

304/316 stainless steel

## Design Conditions

Weight: 0.5 Kg

### Fusible Element:

Operating Temperature: 100°C

Maximum Load: 18.14 Kg

**NOTE:** The Design Conditions and Section View dimensions are for the specified part number only.

### Approvals

Complies with US DOT CFR49 - Ch. 178275 [d]

## Related Parts

Description	Part No.
2.5mm 7x7 strand st/st wire, 6.5m length	6110-022
Remote closure tension spring	5104-203
Footvalve handle remote operating lever	324/7610

## Parts Drawing

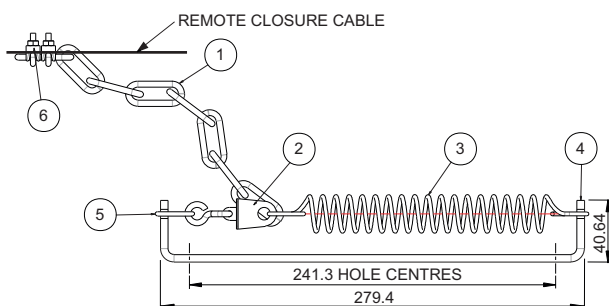

## Parts List

Item	Description	Part No.
1	Stainless steel chain	6128-016
2	100°C fusible element	324/5616
3	Tension spring	252/3272
4	Remote closure bracket	324/5765
5	Solid ring	613/6150
6	Wire clamp (2)	324/5341

## Important Precautions

- A fusible element is designed for a straight pull load. It is not compatible with a radial or twisting load.
- Keep the fusible link assembly in a cool, dry area.
- Do not use the fusible element where the load or temperature will be more than 18.14 Kg and 100°C.
- Do not apply paint or a coating material to the fusible element as this can prevent correct operation.
- Do not apply cleaning chemicals to the fusible element. Cover the element with a clean, wet cloth during cleaning.
- If the fusible link is installed in an atmosphere that can cause stress/strain/corrosion of surfaces, replace the fusible link at least annually if the fusible link shows signs of stress/strain/corrosion.
- Attach the remote closure wire to the chain using cable clamps. There must be the minimum possible amount of slack on the chain when the valve is in the open position.



## Flame Arresters & Debris Protection for Relief Valves

### Accessories & Spare Parts

### Flame Arresters



### Specification

A relief valve flame arrester attaches around the ports of the relief valve body. It prevents an external flame from being transmitted into the tank on relief valves with a vacuum setting of  $\leq 0.21$  Bar (6"Hg).

For relief valves with a vacuum setting of  $> 0.21$  Bar (6"Hg), a flame arrester is frequently used to prevent debris from going into the tank through the relief valve.

#### Nominal sizes

Compatible with 1", 1½" 2½", 65mm and 80mm relief valves

#### Material

Stainless steel

**WARNING:** If you install a flame arrester, it will decrease the air flow capacity of the relief valve. Thus, you must calculate to make sure that the decreased air flow capacity of the relief valve and flame arrester will give sufficient protection to your vessel/system. Refer to Fort Vale for more information.

### Flame Arresters

Each flame arrester is compatible for the specified relief valve type only. Flame arresters are not interchangeable between relief valve types.

**IMPORTANT:** Refer to the air flow decrease data for your valve type. (See **WARNING**)

Compatible Relief Valve	Air Flow Decrease	Part No.
1" Minnow	17% to 20%	179/0300
1½" Twinact	See Note	200/5000
2½" Twinact	See Note	130/5000
2½" & 65mm Super Maxi	1%	176/2900
80mm Hyper Maxi	5.4%	176/2920

**NOTE:** For the air flow decrease data for Twinact relief valves, please contact Fort Vale.

### Debris Protection - Gauzed Cowl

Part No: 176/6000



### Specification

A gauzed cowl attaches to the 65mm Super Maxi relief valve cap. It is used to prevent debris from going into the tank through the relief valve.

#### Nominal sizes

Compatible with a 65mm/2½" Super Maxi relief valve only

#### Material

Stainless steel

**CAUTION:** If you install a gauzed cowl onto a Super Maxi relief valve, it can decrease the relief valve air flow capacity. Refer to Fort Vale for more information.



## Pressure Gauges

### Accessories & Spare Parts

#### Standard Pressure Gauge



#### Tell-Tale Pressure Gauge



#### Specification

We supply standard pressure gauges and tell-tale pressure gauges. Tell-tale pressure gauges have a secondary pointer to indicate if there has been an increase in pressure, even if the pressure subsequently decreases.

All pressure gauges have a 1/4" BSP bottom connection and are glycerine filled.

#### Pressure range options

0-6 Bar, 0-10 Bar, 0-16 Bar, 0-40 Bar

#### Material options - internal parts

Brass, stainless steel

#### Standard Pressure Gauge

Pressure Range Bar	Pressure Range PSI	Internal Parts	Part No.
0-6	0-90	Brass	921/06BBSP
0-6	0-90	St/steel	920/06BBSP
0-10	0-150	Brass	921/10BBSP
0-10	0-150	St/steel	920/10BBSP
0-40	0-580	St/steel	920/40BBSP

#### Tell-Tale Pressure Gauge

Pressure Range Bar	Pressure Range PSI	Internal Parts	Part No.
0-6	0-90	Brass	921/06TTBBSP
0-6	0-90	St/steel	920/06TTBBSP
0-10	0-150	Brass	921/10TTBBSP
0-10	0-150	St/steel	920/10TTBBSP
0-16	0-230	St/steel	920/16TTBBSP
0-40	0-580	St/steel	920/40TTBBSP



## Temperature Gauges

### Accessories & Spare Parts

#### Analogue Temperature Gauge - Capillary



#### Specification: Analogue

##### Temperature range options

-20°C to 160°C

-20°C to 200°C

**NOTE:** The temperature range refers to the capillary or probe only

##### Temperature sensor options

2500mm capillary

250mm stainless steel tube with brass thermowell probe

##### Gauge fill options

Silicone oil filled

Not filled

#### Analogue Temperature Gauge - Probe



#### Analogue Temperature Gauges

Temperature Range		Capillary or Probe	Oil Filled	Part No.
°C	°F			
-20 to 200	-4 to 392	Capillary	Yes	922/TEMP200
-20 to 160	-4 to 320	Capillary	Yes	922/TEMP160
-20 to 200	-4 to 392	Probe	No	922/TEMPT200
-20 to 160	-4 to 320	Probe	No	922/TEMPT160

**NOTE:** The temperature range refers to the capillary/probe only.

#### Digital Temperature Gauge - Capillary

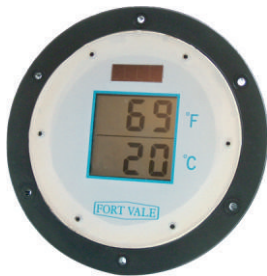

#### Specification: Digital

##### Temperature range options

-200°C to 250°C

**NOTE:** The temperature range refers to the capillary or probe only

##### Temperature sensor options

1000mm capillary

#### Digital Temperature Gauge

Temperature Range		Capillary or Probe	Part No.
°C	°F		
-200 to 250	-328 to 482	Capillary	922/TEMPDIGI250

**NOTE:** The temperature range refers to the capillary/probe only.





## After Sales Service

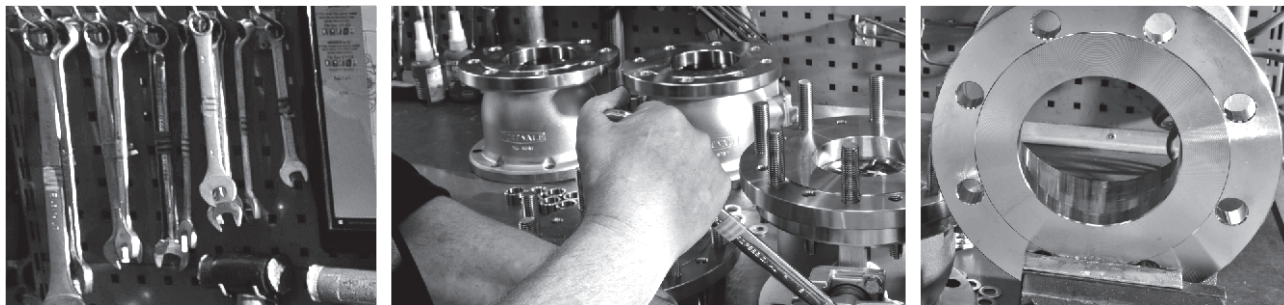

We offer a refurbishment and repair services for all our valves. We can also provide you with technical support if you want to do your own maintenance. Please contact us for more information about maintenance instruction manuals and special tools and equipment.

We keep a wide range of spare parts and ancillary items in stock at our Fort Vale worldwide locations. We also have authorised distributors around the world who can supply you with replacement and consumable parts, and help you with after sales service.





## Valve Repair and Maintenance Accessories & Spare Parts



We supply a range of special tools and repair kits to do scheduled maintenance and repair procedures to our valves.

We recommend that you use the correct special tools to help you do maintenance and repairs quickly and easily without causing damage to the valve or the new spare parts.

A selection of step-by-step maintenance instruction manuals is also available, please contact us.

**CAUTION:** Valve maintenance and repair can be dangerous. To do maintenance, you must have experience and qualifications related to valve installation on pressure vessels and systems.

### Relief Valve Pressure/Vacuum Test Rig Part No: 400/8000



#### Specification

You can use the relief valve test rig to test the pressure and vacuum setting of Hyper Maxi, Super Maxi, Twinact, Uniact, Minnow and Steam relief valves.

#### Valve connection

2½" BSP: We supply adaptors to change to other BSP and flanged connections

#### Test rig supply connection

¼" BSP female socket

#### Test range

From -0.7 Bar to 6.9 Bar (-10 PSI to 100 PSI)

#### Related documents

Operating Instructions: OPIN26. Please contact us

### Footvalve & Relief Valve Seat Repair Kit Part No: 3" Kit - 400/2600 Part No: 4" Kit - 400/2900



#### Specification

You can use the seat repair kit to re-surface the seating face of a valve if there is damage caused by corrosion.

#### Compatible

**3" Kit:** compatible with 2½" Super Maxi relief valve and 3" Cleanflow and Highlift footvalves

**4" Kit:** compatible with 4" Cleanflow & Highlift footvalves

#### Connection

Compatible with power tools with a ½" chuck

#### Kit contents

Selection of grinding and polishing discs

Selection of face-forming tools

Instruction manual

#### Related documents

Operating Instructions: 3" Kit OPIN70, 4" Kit OPIN77. Please contact us.

#### Spare Parts: Grinding Discs

Description	Part No. 3"	Part No. 4"
Box of 100 x 60 grit	400/2610	400/2615
Box of 100 x 80 grit	400/2620	400/2625
Box of 100 x 180 grit	400/2630	400/2635
Box of 100 x 500 grit	400/2640	400/2645



## Valve Repair and Maintenance Accessories & Spare Parts



### Relief Valve Tool Kits

Description	Part No.
Test rig adaptor flange: Adapts 2½" BSP to 3" ASA150, DIN65 PN10 & DIN80 PN6	425/1000
C spanner: To install/remove Twinact relief valves	400/3000
C spanner: To install/remove Super Maxi relief valves	400/3001
Tightening tool for MKIII Super Maxi relief valves	400/8380
Tool kit: 1½" & 2½" Twinact valves	400/1000
Tool kit: 65mm & 80mm Super Maxi & Hyper Maxi relief valves	400/8300



### Footvalve Tool Kits

Description	Part No.
Tool kit: 3" Cleanflow footvalve	400/2150
Tool kit: 3" Highlift footvalve	400/2450



### Ball Valve Tool Kits

Description	Part No.
Spindle O ring stuffing tool: 1½" MKIII airline ball valve - 530/type	FIX/A/0075/2
Tool kit: 1½" MKII airline ball valve - 353/type	400/2500
Tool kit: 3" ball valve spindle O ring tools - 360/5XXX type valves	400/2200STK
Tool kit: 3" ball valve - 360/0000 type valves, pre-2003	400/2200

### Butterfly Valve Tool Kits

Description	Part No.
Tool kit: 2" butterfly valve	400/2300
Tool kit: 3" butterfly valve	400/2700



# Bolt Torque Guide & Step Loading Procedure

## Installation & Operating Instructions

### Flange Bolting

**CAUTION:** Weld-distortion and too much tightening force will cause damage to a flange.

It is important not to cause damage to weld-in flanges and mating flanges. If a flange is damaged it will not give a satisfactory seal when a gasket and secondary mating flange is installed.

Bolt-stress can decrease after initial tightening. The cause can be deformation of the gasket material, particularly with soft materials such as a CNAF/PTFE envelope gasket.

Best procedure recommends that, after initial bolting, the flange joint is tightened again after a period of time. Most gasket manufacturers advise a period of 24 hours. ASME PCC-1-2000 GUIDELINES FOR PRESSURE BOUNDARY BOLTED FLANGE JOINT ASSEMBLY advises a minimum period of 4 hours.

Bolt torque calculations are based on a flat flange to within 0.15mm.

Recommended bolt torque values will be reduced if a lubrication is used.

### Bolt Torque

#### Bolt Torque Values

Fort Vale bolt torque values are given as a reference guide only and are based on:

- the use of a CNAF/PTFE gasket.
- unlubricated fasteners.
- a flange flat to within 0.15mm.

**CAUTION:** If you use a different gasket material, a lubricant or a flange with distortion, you must re-calculate the torque value.

#### Bolt Torque Procedure

To install flanged parts correctly:

- Examine the mating flange of the part.
- If the flange is marked with a torque value, obey that torque value.
- If there is no torque value marked on the mating flange, obey the bolt torque values given in Table BT1.
- Tighten the bolts evenly in sequence. Refer to Figure BT1.
- Obey the Step Loading Procedure (ASME PCC-1-2000). Refer to the next page.

Table BT1

Thread	Torque Value
M10	30 Nm (22 lbf.ft)
M12	65 Nm (48 lbf.ft)
M16	81 Nm (60 lbf.ft)

Figure BT1

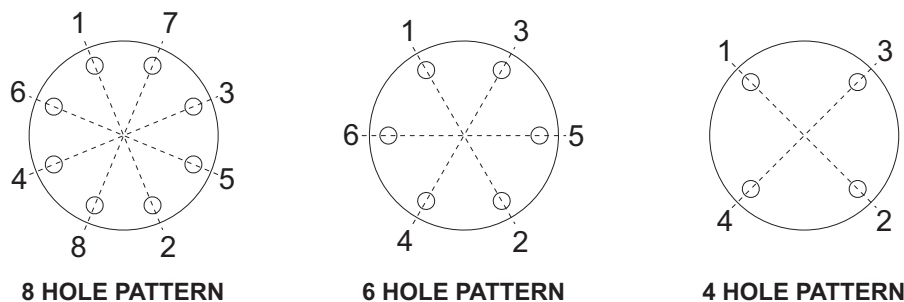



## **Bolt Torque Guide & Step Loading Procedure**

### **Installation & Operating Instructions**

---

### **Step Loading Procedure**

To install flanged parts correctly, obey the Step Loading Procedure extract from ASME PCC-1-2000:

#### **Install**

Hand tighten, then “snug up” to 15 Nm (10 lbf.ft) to 30 Nm (20 lbf.ft) (not to exceed 20% of Target Torque). Check flange gap around circumference for uniformity. If the gap around the circumference is not reasonably uniform, make the appropriate adjustments by selective tightening before proceeding.

#### **Round 1**

Tighten to 20% to 30% of Target Torque. Check flange gap around circumference for uniformity. If the gap around the circumference is not reasonably uniform, make the appropriate adjustments by selective tightening before proceeding.

#### **Round 2**

Tighten to 50% to 70% of Target Torque. Check flange gap around circumference for uniformity. If the gap around the circumference is not reasonably uniform, make the appropriate adjustments by selective tightening before proceeding.

#### **Round 3**

Tighten to 100% of Target Torque. Check flange gap around circumference for uniformity. If the gap around the circumference is not reasonably uniform, make the appropriate adjustments by selective tightening before proceeding.

#### **Round 4**

Continue tightening the bolts, but on a rotational clockwise pattern until no further nut rotation occurs at the Round 3 Target Torque value. For indicator bolting, tighten bolts until the indicator rod retraction readings for all bolts are within the specified range.

#### **Round 5**

Time permitting, wait a minimum of 4 hr and repeat Round 4; this will restore the short-term creep relaxation/embedment losses. If the flange is subjected to a subsequent test pressure higher than its rating, it may be desirable to repeat this round after the test is completed.



## Client Responsibilities - Valves & Accessories

### Installation, Operation & Maintenance Instructions

## Compatibility

Make sure that the function and technical specification of the valve/accessory is compatible with the vessel service conditions and the cargo. This includes, but is not limited to:

- dimensions.
- pressure/vacuum setting.
- air/vapour/liquid flow capacity.
- maximum allowable working pressure.
- test pressure.
- minimum/maximum design temperatures.
- materials of construction.

## Maintenance and Inspection

Fort Vale valves and accessories have a long life if you use them correctly in compatible service conditions. It is not necessary to lubricate the parts, but we recommend that you do the inspections that follow:

### Inspections at regular intervals:

1. Examine the valve to make sure there is no damage, wear or corrosion.
2. Examine the valve and adjacent area to make sure there is no leakage of cargo.
3. Examine the fasteners to make sure they are not loose.
4. Make sure the valve operates correctly.

**CAUTION:** If you operate the valve with very corrosive cargo, or near its temperature and/or pressure limit (very high or very low temperature and/or pressure), do the inspections more frequently.

Also, schedule regular maintenance based on how frequently the valve is used, the type of cargo and the service conditions.

### Inspections after 2½ years of service or a minor incident:

1. Examine the valve to make sure there is no damage, wear or corrosion.
2. Make sure the valve operates correctly.
3. Do a pressure test on the valve.

### Inspections after 5 years of service or a major incident:

1. Disassemble and clean the valve.
2. Replace all the valve seals and do a pressure test.

## Replacement Parts

Do not adapt or change the valve. If you install a replacement part, it must be a genuine Fort Vale part.

**WARNING:** If you install a part that is not genuine, there is a risk of:

- injury to personnel.
- permanent damage to the valve.
- permanent damage to the vessel.
- valve malfunction.

## External Fire

If you install the valve in an area where there is a risk of external fire, you must install compatible accessories to prevent damage to the valve.

## Compatibility of Accessories

Accessory components must cause no interference with the valve's function. Accessories must be made from compatible materials that will cause no damage to the valve materials. Do not install an accessory that will cause an increased load on the valve, such as mechanical, static, dynamic or thermal load.

## Mis-use

Obey the instructions and recommended procedures in the installation and operating instructions. Obey the pressure and temperature markings on the valve and on the drawing. Use the valve/accessory for its correct function only. Fort Vale accept no liability or responsibility for incorrect use of the valve/accessory.







Our subsidiaries are located in:

**US Office**

126 N. Virginia  
La Porte  
TX 77571  
USA

Tel: +1 281 471 8100

Fax: +1 281 471 8116

Email: [ussales@fortvale.com](mailto:ussales@fortvale.com)

**Head Office**

Calder Vale Park  
Simonstone Lane  
Simonstone, Burnley  
Lancashire, BB12 7ND, UK

Tel: +44 (0) 1282 687120

Fax: +44 (0) 1282 687110

Email: [sales@fortvale.com](mailto:sales@fortvale.com)

**China Office**

Fort Vale Engineering Shanghai Ltd  
Building 11 88 Yuanshan Road  
Xinzhuang Industry Park  
Shanghai 201108 China

Tel: +86 21 6442 1367

Fax: +86 21 6442 1376

Email: [cnsales@fortvale.com](mailto:cnsales@fortvale.com)

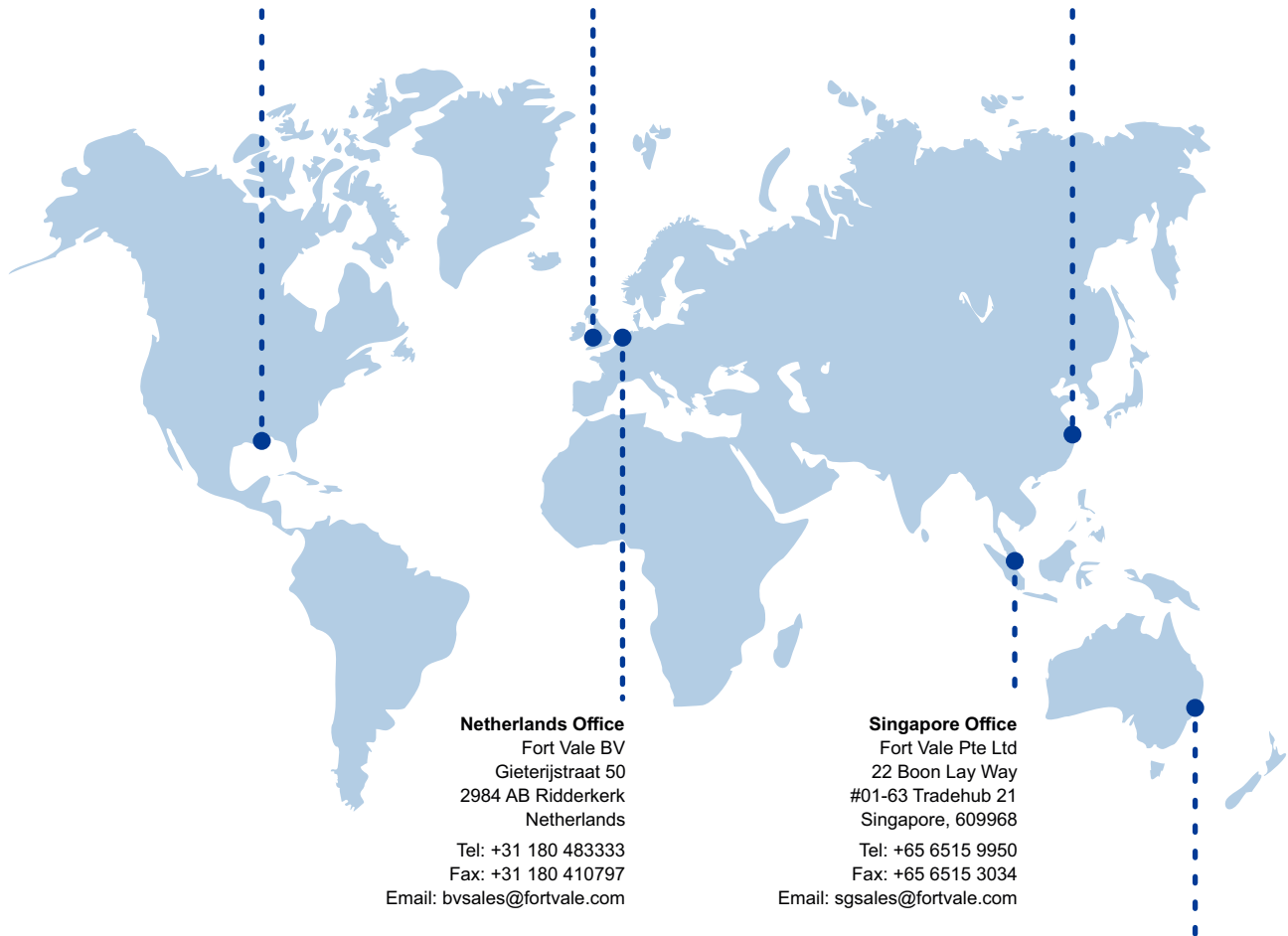

**Netherlands Office**

Fort Vale BV  
Gieterijstraat 50  
2984 AB Ridderkerk  
Netherlands

Tel: +31 180 483333

Fax: +31 180 410797

Email: [bvsales@fortvale.com](mailto:bvsales@fortvale.com)

**Singapore Office**

Fort Vale Pte Ltd  
22 Boon Lay Way  
#01-63 Tradehub 21  
Singapore, 609968

Tel: +65 6515 9950

Fax: +65 6515 3034

Email: [sgsales@fortvale.com](mailto:sgsales@fortvale.com)

**Australia Office**

Fort Vale Australia Pty Ltd  
Bellwood Business Park  
Unit 14, 49 Bellwood Street  
Darra, Queensland, 4076

Tel: +61 7 3189 5059

Email: [ausales@fortvale.com](mailto:ausales@fortvale.com)

We also have Authorised Distributors around the world to provide you with product sales and after-market services. To find your nearest distributor, please visit our website - [www.fortvale.com](http://www.fortvale.com)

