



Specification

The ACME outlet assembly is a tertiary closure system for liquefied gas discharge assemblies. It includes a spigot flange and a plug/cap assembly with a PTFE seal and retaining wire.

Nominal sizes

DN25, 1 3/4" ACME thread: compatible with vapour phase
 DN50, 3 1/4" ACME thread: compatible with liquid phase

Connection

4 x 18mm holes on a 125mm PCD

Properties

1/4" NPT connection for a sample/bleed valve or a pressure gauge. Safety bleed hole in the spigot.

Materials

Metal parts: 316 stainless steel
 Seal: PTFE

Design Conditions

Design Pressure (MAWP):	34.5 Bar
Test Pressure:	70.0 Bar
Design Temperature Min:	-50°C
Design Temperature Max:	80°C

Range

Description	Part No.
DN25 1 3/4" ACME thread	252/2187
DN50 3 1/4" ACME thread	252/2177

Spare Parts

Item	Description	Part No. 1 3/4" ACME	Part No. 3 1/4" ACME
1.	Outlet flange	252/2084	252/2069
2.	ACME cap	252/2085	252/2075
3.	ACME plug	252/2086	252/2076
4.	Retaining ring clip	5120-028	5120-027
5.	PTFE seal	5005-878	5005-877
6.	Retaining wire	425/0009	425/0004

Section View - 1 3/4", Part No. 252/2187

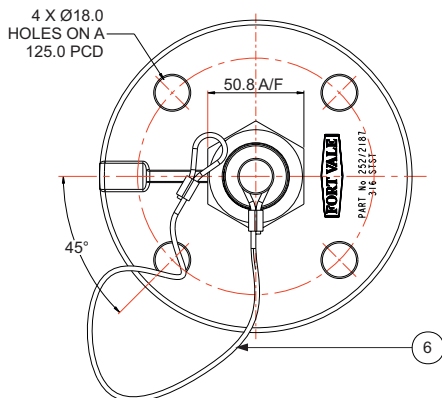
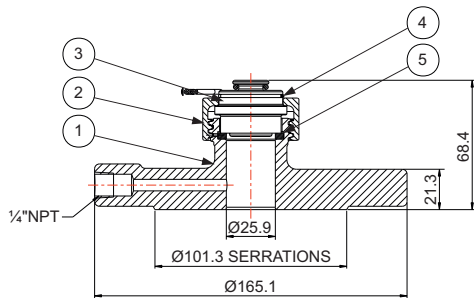

Section View - 3 1/4", Part No. 252/2177

