

Specification

Nominal size/body angle
80mm / 45°

Inlet connection

Flanged: 8 x 14mm holes equi-spaced on a 178mm PCD

Outlet connection

Flanged: 4 x 17mm holes on a 160mm PCD

Materials

Contact parts: 316 stainless steel with PFA moulded lining

Main seal: Fortyt

Design Conditions

Weight:	11.8 Kg
Design Pressure (MAWP):	4 Bar
Test Pressure:	6 Bar
Design Temperature Min:	-40°C
Design Temperature Max:	200°C

NOTE: The Design Conditions and Section View dimensions are for the specified part number only.

Design Codes

BS EN 14433

Related Parts

Description	Part No.
Weld-in flange for lining	324/9000L
Stud kit	312/1177

GASKETS: Do not install an inlet gasket.

If you install a Fort Vale PFA lined ball valve or PFA lined butterfly valve to the outlet, do not install an intermediate gasket.

Section View

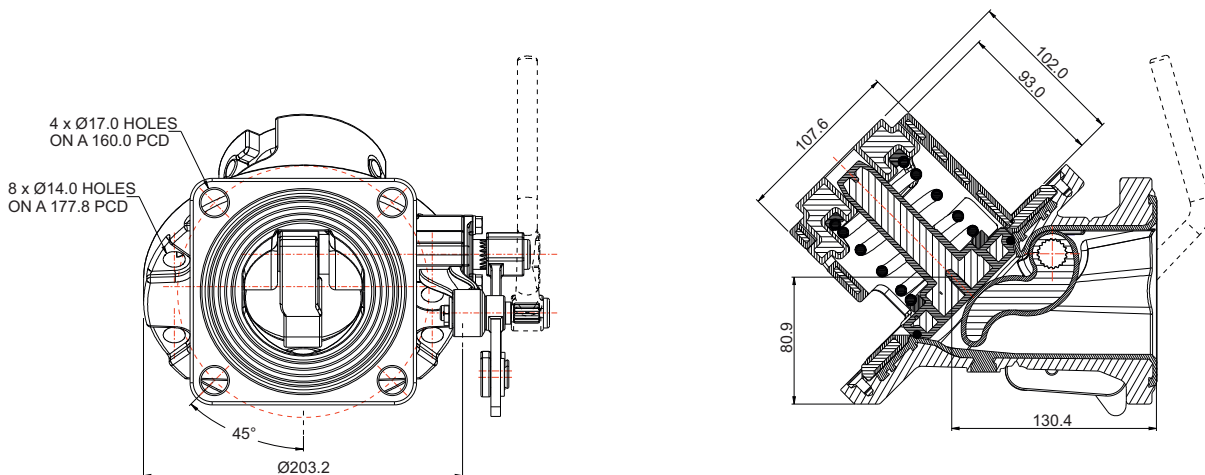

Parts Drawing

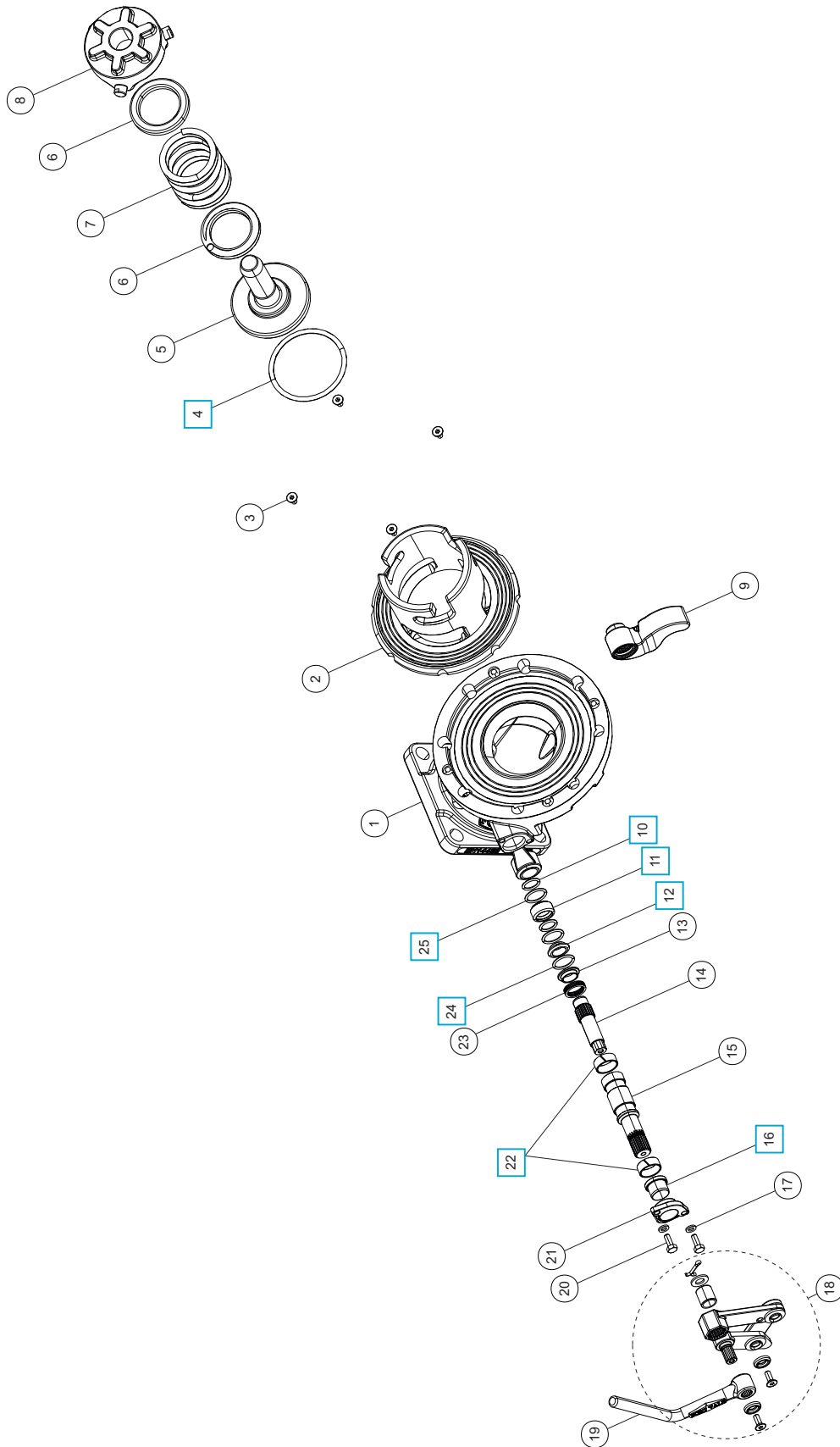

Parts List

Item	Description	Part No.
1	PFA lined body	870/P1370LM
2	PFA lined cage	870/P1371LM
3	6mm countersunk bolt (4)	5111-018
4	Fortyt O ring	ORB337F1 <input type="checkbox"/>
5	PFA lined poppet	870/P125LM
6	PTFE spring support plate (2)	870/1146
7	PFA lined spring	5104-865P
8	PFA lined spring retainer cap	870/P1374LM
9	PFA lined lifting fork	870/P124L
10	Viton O ring (2)	5005-134V <input type="checkbox"/>
11	RTFE spindle bush	870/P127/1 <input type="checkbox"/>
12	RTFE spindle bush	870/P127/2 <input type="checkbox"/>
13	Spring housing bush	845/P127/4
14	Spindle section 2	870/P128
15	Spindle section 1	870/P129
16	PTFE spindle stuffing seal	845/0061 <input type="checkbox"/>
17	M6 spring washer (2)	5113-008
18	Handle linkage assembly	324/8910
19	Handle *Note	324/8670
20	M6 hex bolt (2)	5111-022
21	Stuffing clamp flange	870/P1376C
22	Split bearing (2)	874/0023 <input type="checkbox"/>
23	Spirawave spring	5104-027
24	Viton O ring	5005-336 <input type="checkbox"/>
25	Perfluoroelastomer O ring (2)	5005-384 <input type="checkbox"/>

NOTE: The handle is sold separately. We recommend the handle shown, but other types are available.

Seal Kit

Description	Part No.
All parts marked <input type="checkbox"/> in the Parts List	870/P12SK