



## Specification

### Nominal size

50mm

### Body type

Clamped

### Properties

In-line spindle and closure plate

Left hand operated, handle with TIR and padlock slots

### Materials

Contact parts: PFA lined

Alternatives are available, refer to the Design Options page

## Design Conditions

Weight:	2.2 Kg
Design Pressure (MAWP):	4 Bar
Test Pressure:	6.4 Bar
Design Temperature Min:	-40°C
Design Temperature Max:	150°C

**NOTE:** The Design Conditions and Section View dimensions are for the specified part number only.

### Design Code

BS EN 14432

## Range

Description	Part No.
2" clamped PFA lined butterfly valve	258/P700
3" clamped PFA lined butterfly valve	358/P700

## Section View

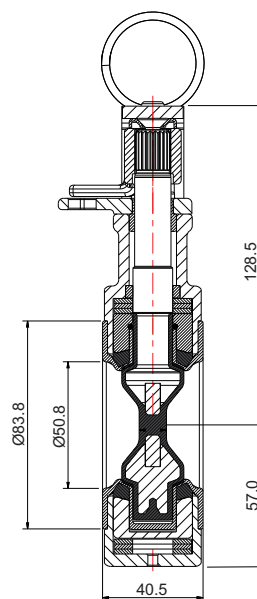
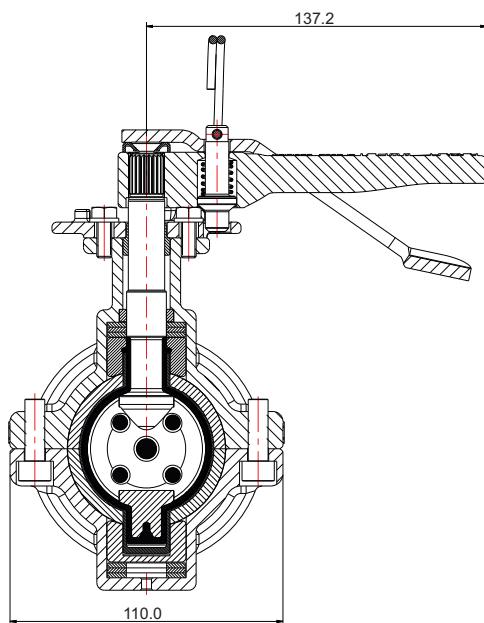

## Parts Drawing

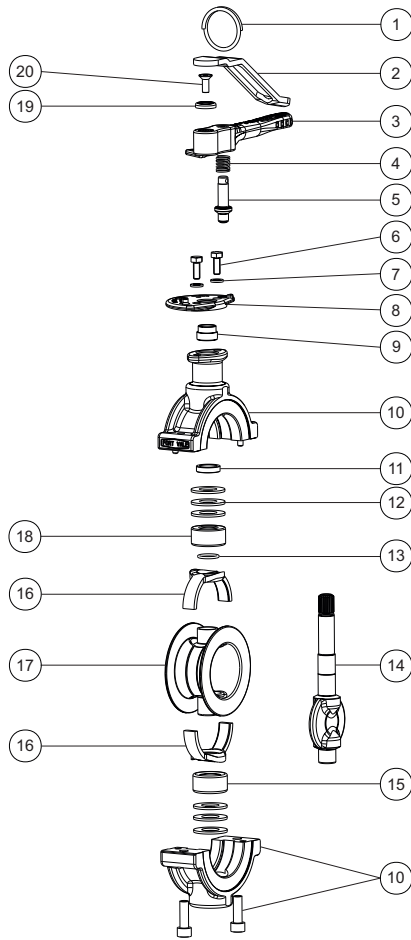

## Parts List

Item	Description	Part No.
1	Split ring	368/0011
2	Handle lever	368/9838
3	Handle	368/0051
4	Handle spring	368/0012
5	Handle location pin	368/0010
6	M6 hex bolt (2)	5111-022
7	M6 spring washer (2)	5113-008
8	Stuffing clamp	535/0204
9	Stuffing clamp bush	368/0301
10	Body assembly	258/P253
11	Top guide bush	358/P236
12	Belleville washer (6)	5113-052
13	Perfluoroelastomer O ring	5005-216PER
14	PFA lined spindle/closure plate	258/P235
15	Bottom thrust bearing	358/P233/1
16	Backing rubber (2)	258/P257
17	PFA body seal	258/P250
18	Stem seal housing	358/P233
19	Retaining washer	20370
20	M6 countersunk bolt	5111-030