



Catalogue

Standard Range of General Relief Valves



CONTENTS

General Relief Valves

Catalogue

3/4" Steam Relief Valves

3/4" BSPT Steam Relief Valve	3
3/4" BSPT Steam Tell-Tale Valve	5

1" & 2" Minnow / IBC Relief Valves

Design Options: Minnow Relief Valves	7
1" BSPM: Pressure Only	9
1" BSPM: Pressure/Vacuum	11
1" BSPF Ventlock: Pressure/Vacuum	13
2" BSP Low Profile: Pressure/Vacuum	15
2" BSP: Pressure/Vacuum	17

1 1/2" & 2" Uniact Relief Valves

Design Options: Uniact Relief Valves	19
1 1/2" BSP: Pressure Only	21
1 1/2" BSP: Vacuum Only	23
2" BSP: Vacuum Only	25

Continued over



CONTENTS

General Relief Valves

Catalogue

1½” & 2½” Twinact Relief Valves

Design Options: Twinact Relief Valves	27
1½" BSP: Pressure Only	29
1½" BSP: Pressure/Vacuum	31
50mm DIN11851: Pressure/Vacuum	33
2½" BSP: Pressure Only	35
2½" BSP: Pressure/Vacuum	37
80mm DIN11851: Pressure/Vacuum	39

Accessories

Flame Arresters & Debris Protection	41
Pressure Gauges	42
Weld-in Sockets	43
Valve Repair & Maintenance	44

Appendix

Client Responsibilities	48
Fort Vale Worldwide	49



3/4" BSPT Steam Relief Valve

Part No: 58/0XXX00



Specification

Nominal size

DN20

Tank connection

3/4" BSPT (taper)

Set pressure

From 5 PSI to 225 PSI (0.34 Bar to 15.52 Bar)

Materials

Contact parts: 316 stainless steel

Pressure O ring: Viton GFLT

Alternatives are available, refer to Range

Design Conditions

Weight:	0.6 Kg
Design Pressure (MAWP):	16.5 Bar
Design Temperature Min:	-40°C
Design Temperature Max:	200°C

NOTE: The minimum re-seal temperature is -25°C.
The Design Conditions and Section View dimensions are for the specified part number only.

Range

Description	Part No.
Standard specification	58/0XXX00

NOTE: The pressure setting changes the Part No.

Section View

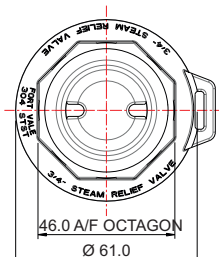
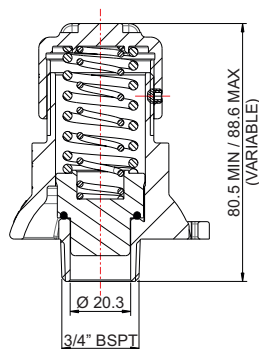



3/4" BSPT Steam Relief Valve

Part No: 58/0XXX00

Parts Drawing

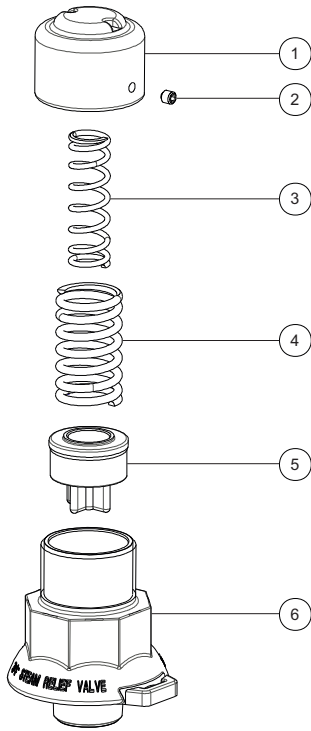

Parts List

Item	Description	Part No.
1	Cap	58/03650
2	Set screw	5121-001
3	Inner spring *Note	5104-90XX
4	Outer spring *Note	5104-9XXX
5	Poppet assembly with Viton GFLT seal *Note	58/0362X
6	Body	58/03640

NOTE: The pressure setting changes the Part No.



3/4" BSPT Steam Tell-Tale Valve

Part No: 56/0XXX0



Specification

Nominal size

DN20

Tank connection

3/4" BSPT (taper)

Set pressure

From 3 PSI to 150 PSI (0.21 Bar to 10.34 Bar)

Materials

Contact parts: 316 stainless steel

Pressure O ring: Viton

Alternatives are available, refer to Range

Design Conditions

Weight: 0.1 Kg
 Design Pressure (MAWP): 10.3 Bar
 Design Temperature Max: 200°C

NOTE: The Design Conditions and Section View dimensions are for the specified part number only.

Range

Description	Part No.
Standard specification	56/0XXX0
With TIR tab on valve body	56/0XXX0T
3/4" NPTM connection	52/0XXX0

NOTE: The pressure setting changes the Part No.

Section View

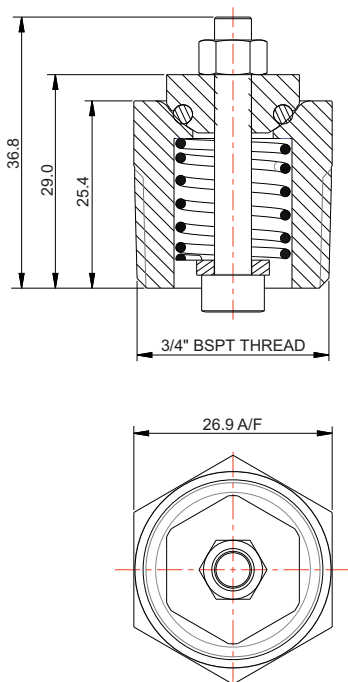



3/4" BSPT Steam Tell-Tale Valve

Part No: 56/0XXX0

Parts Drawing

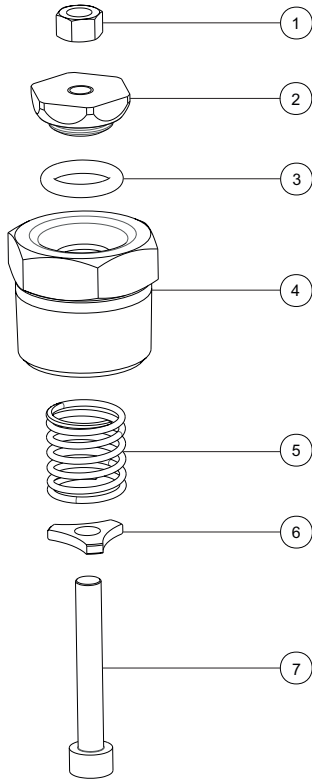

Parts List

Item	Description	Part No.
1	M5 nut	5112-010
2	Poppet head	54/00003
3	Viton O ring	5005-650
4	Body	54/00001
5	Spring *Note	5104-XXXXA
6	Spring locator	54/00002
7	M5 cap screw	5111-128

NOTE: The pressure setting changes the Part No.



Minnow Relief Valves

Design Options

Function

A relief valve is installed in the vapour space of a tank. It vents to protect the tank from accidental over-pressure or unwanted vacuum conditions. Minnow relief valves are pre-set to give protection against pressure only or against pressure and vacuum.

We offer a range of relief valves for different service conditions and flow requirements. Contact us for more information.

Design Options

The design options below are available on our standard range of Minnow relief valves.

Tank Connection

Threaded: 1" BSP male,
1" BSP female, 1" NPT male



Tank Seal

PTFE

Nominal Bore

25mm (1")

Pressure Setting

Standard valve:
From 1 PSIG to 45 PSIG
(0.07 Bar to 3.10 Bar)

Ventlock valve:
From 1 PSIG to 9 PSIG only
(0.07 Bar to 0.62 Bar only)

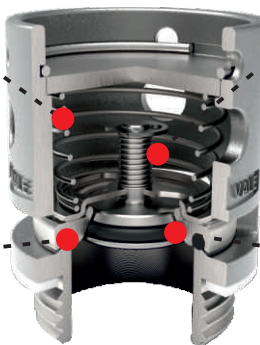

Vacuum Setting

From 0.5"Hg to 7"Hg
(0.02 Bar to 0.24 Bar)

Pressure Seal

Viton

Special service conditions:
A range of elastomer seals is
available

Vacuum Seal

Viton

Special service conditions:
A range of elastomer seals is
available

Special Options

Manual vacuum vent button
Ventlock bracket
Body with TIR bracket



Valve Materials

316 stainless steel

Special service conditions:
Wetted parts in high nickel alloys



Minnow Relief Valves

Design Options

Related Parts

We recommend our range of compatible accessories:

- Flame arrester
- Weld-in sockets and nipples

Please contact us for more information about these parts.

Relief Valves for Dedicated Service

We offer a range of relief valves for these service conditions and special cargoes:

- T50 tank containers for liquefied gas
- Rail tank wagons
- U.S. tank trucks
- IBCs and small capacity tanks
- Steam-heating systems for tanks
- Hygienic service
- Food grade for liquid flow

Please contact us for more information about these valves.



1" BSP Minnow Relief Valve - Pressure Only

Part No: 65/0XX00



Specification

Nominal size

DN25

Tank connection

1" BSPM

Set pressure

From 1 PSI to 45 PSI (0.07 Bar to 3.10 Bar)

Materials

Contact parts: 316 stainless steel

Pressure O ring: Viton

Tank seal: PTFE

Alternatives are available, refer to the Design Options page

Design Conditions

Weight: 0.18 Kg

Seal Temperature Range:

Material	Min.Temp.°C	Max.Temp.°C
EPDM	-50	150
Perfluoroelastomer	-15	240
Viton	-20	200

NOTE: The Design Conditions and Section View dimensions are for the specified part number only.

Range

Description	Part No.
1" BSPM standard valve	65/XXXXXX
1" BSPM with vent button	65B/XXXXXX
1" BSPM with vent button & TIR	65BT/XXXXXX
1" BSPM with vent button & ventlock	68/XXXXXX
1" BSPF standard valve	66/XXXXXX
1" BSPF with vent button & ventlock	69/XXXXXX
1" NPT standard valve	65/XXXXXNPT

NOTE: The valve specification changes the part number

Related Parts

Description	Part No.
1" BSP weld-in socket	600/1025
1" BSP weld-in nipple	600/1026
1" flame arrester	179/0300

Section View

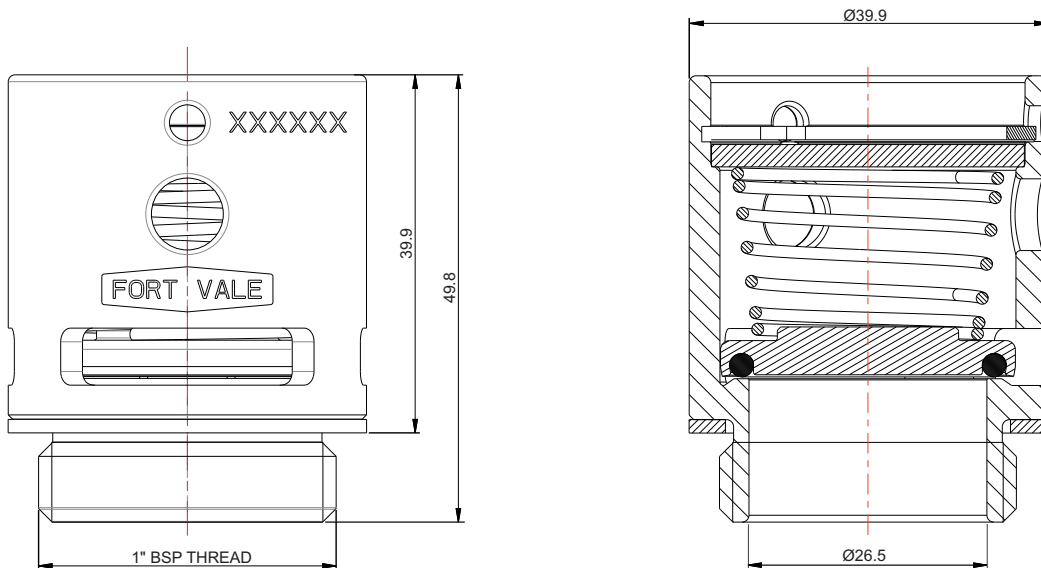



1" BSP Minnow Relief Valve - Pressure Only

Part No: 65/0XX00

Parts Drawing

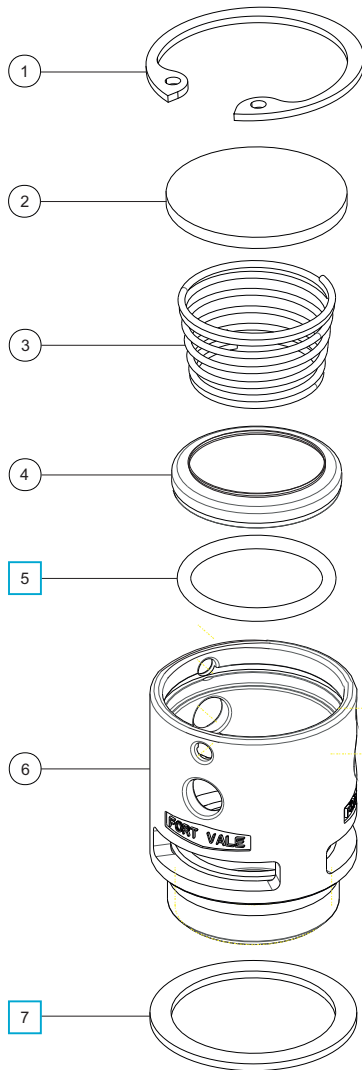

Parts List

Item	Description	Part No.
1	Retaining clip	5120-021
2	Top cap	179/0010
3	Pressure spring	Refer to Table 1
4	Pressure plate *Note	Refer to Table 2
5	Pressure O ring *Note	Refer to Table 2 <input type="checkbox"/>
6	Body	179/0100
7	PTFE gasket	5005-553 <input type="checkbox"/>

NOTE: You will need special tools to install an O ring into a pressure plate. We recommend that you order a pressure plate/O ring assembly. Refer to Table 2.

Table 1

Std. Pressure Settings	Pressure Spring Part No.
3 PSI (0.21 Bar)	5104-653
6 PSI (0.41 Bar)	5104-656
9 PSI (0.62 Bar)	5104-659
30 PSI (2.07 Bar)	5104-695

Available settings: 1 PSI (0.07 Bar) to 45 PSI (3.10 Bar)

Table 2 - Refer to Note

Seal Material	Pressure O Ring	Pressure Plate/O Ring Assembly
EPDM	5005-651	179/0050ES
Perfluoroelastomer	5005-585	179/0050PERS
Viton	5005-552	179/0050VS

Seal Kit - All parts marked in the Parts List

Seal Material	Part No.
EPDM	65/9PSK
Perfluoroelastomer	65/7PSK
Viton	65/0PSK



1" BSP Minnow Relief Valve - Pressure/Vacuum

Part No: 65X/0XXXX



Specification

Nominal size

DN25

Tank connection

1" BSPM

Set pressure

From 1 PSI to 45 PSI (0.07 Bar to 3.10 Bar)

Set vacuum

From 0.5"Hg to 7"Hg (0.02 Bar to 0.24 Bar)

Properties

With or without manual vent button, refer to Section View

Materials

Contact parts: 316 stainless steel

Pressure O ring: Viton

Vacuum O ring: Viton

Tank seal: PTFE

Alternatives are available, refer to the Design Options page

Design Conditions

Weight: 0.19 Kg

Seal Temperature Range:

Material	Min.Temp.°C	Max.Temp.°C
EPDM	-50	150
Perfluoroelastomer	-15	240
Viton	-20	200

NOTE: The Design Conditions and Section View dimensions are for the specified part number only.

Range

Description	Part No.
1" BSPM standard valve	65/XXXXX
1" BSPM with vent button	65B/XXXXX
1" BSPM with vent button & TIR	65BT/XXXXX
1" BSPM with vent button & ventlock	68/XXXXX
1" BSPF standard valve	66/XXXXX
1" BSPF with vent button & ventlock	69/XXXXX
1" NPT standard valve	65/XXXXXNPT

NOTE: The valve specification changes the part number

Related Parts

Description	Part No.
1" BSP weld-in socket	600/1025
1" BSP weld-in nipple	600/1026
1" flame arrester	179/0300

Section View

With manual Vent button: 65B/0XXXX

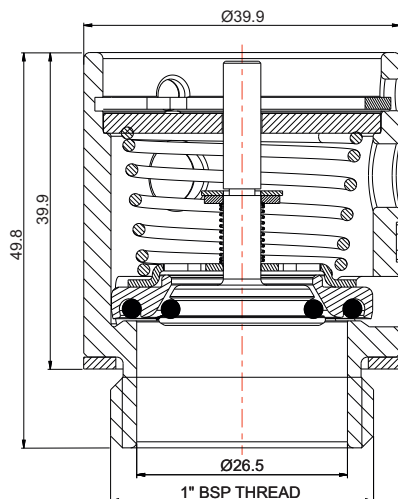

Without manual Vent button: 65/0XXXX

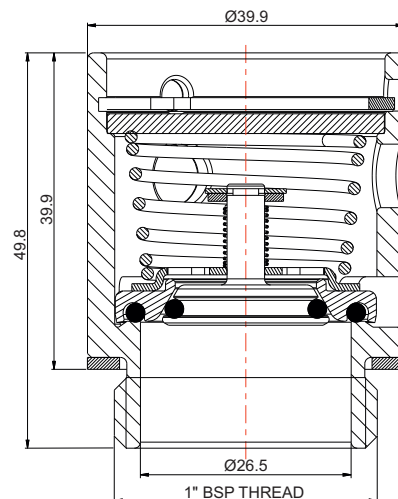



1" BSP Minnow Relief Valve - Pressure/Vacuum

Part No: 65X/0XXXX

Parts Drawing

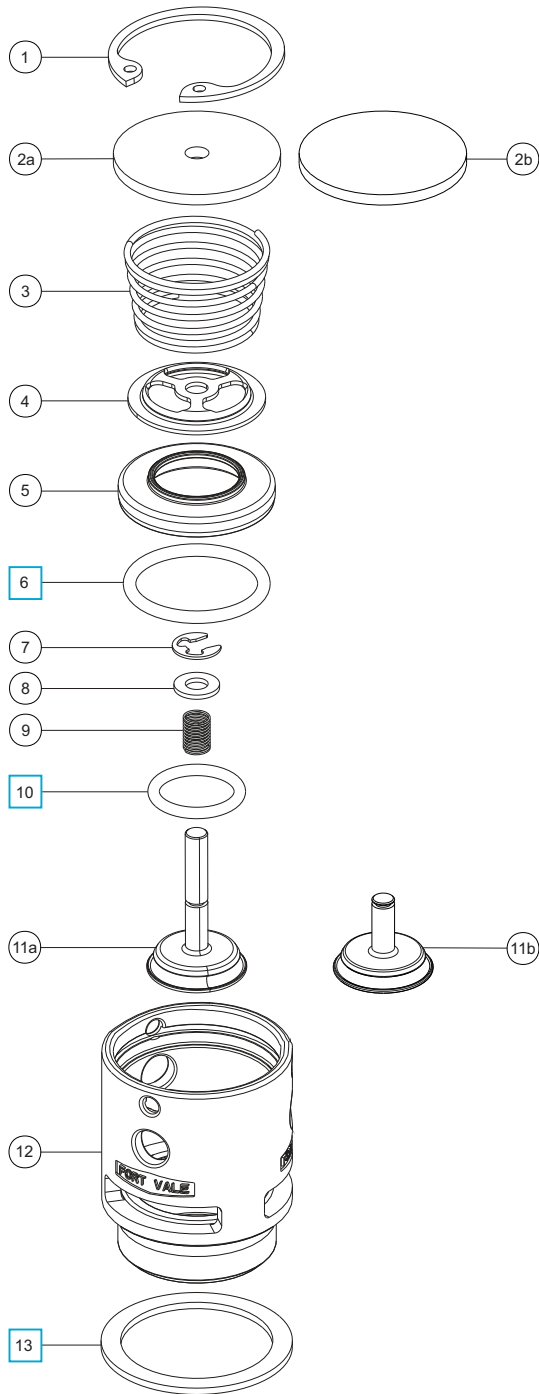

Parts List

Item	Description	Part No.
1	Retaining clip	5120-021
2a	Top cap: for vent button	179/0060
2b	Top cap: no vent button	179/0010
3	Pressure spring	Refer to Table 1
4	Poppet guide	179/0055
5	Pressure plate *Note	Refer to Table 2
6	Pressure O ring *Note	Refer to Table 2 <input type="checkbox"/>
7	Circlip	5120-002
8	Plain washer	5113-017
9	Vacuum spring	Refer to Table 3
10	Vacuum O ring	Refer to Table 4 <input type="checkbox"/>
11a	Vacuum poppet: with vent button	179/0070
11b	Vacuum poppet: no vent button	179/0020
12	Body	179/0100
13	PTFE gasket	5005-553 <input type="checkbox"/>

NOTE: You will need special tools to install an O ring into a pressure plate. We recommend that you order a pressure plate/O ring assembly. Refer to Table 2.

Table 1

Std. Pressure Settings	Pressure Spring Part No.
3 PSI (0.21 Bar)	5104-653
6 PSI (0.41 Bar)	5104-656
9 PSI (0.62 Bar)	5104-659

Available settings: 1 PSI (0.07 Bar) to 45 PSI (3.10 Bar)

Table 2 - Refer to Note

Seal Material	Pressure O Ring	Pressure Plate/O Ring Assembly
EPDM	5005-651	179/0040ES
Perfluoroelastomer	5005-585	179/0040PERS
Viton	5005-552	179/0040VS

Table 3

Std. Vacuum Setting	Vacuum Spring Part No.
1"Hg (0.03 Bar)	5104-671

Available settings: 0.5"Hg (0.02 Bar) to 7"Hg (0.24 Bar)

Table 4

Seal Material	Vacuum O ring
EPDM	5005-652
Perfluoroelastomer	5005-586
Viton	20361

Seal Kit - All parts marked in the Parts List

Seal Material	Part No.
EPDM	65/9PVSK
Perfluoroelastomer	65/7PVSK
Viton	65/0PVSK



1" BSPF Minnow Ventlock Relief Valve - Pressure/Vacuum

Part No: 69/0XXXX



Specification

Nominal size

DN25

Tank connection

1" BSPF

Set pressure

From 1 PSI to 9 PSI max. (0.07 Bar to 0.62 Bar max.)

Set vacuum

From 0.5"Hg to 7"Hg (0.02 Bar to 0.24 Bar)

Properties

With manual vent button and ventlock

Materials

Contact parts: 316 stainless steel

Pressure O ring: Viton

Vacuum O ring: Viton

Tank seal: PTFE

Alternatives are available, refer to the Design Options page

Design Conditions

Weight: 0.22 Kg

Seal Temperature Range:

Material	Min.Temp.°C	Max.Temp.°C
EPDM	-50	150
Perfluoroelastomer	-15	240
Viton	-20	200

NOTE: The Design Conditions and Section View dimensions are for the specified part number only.

IMPORTANT: The maximum set pressure for a Ventlock valve is 9 PSI (0.62 Bar)

Range

Description	Part No.
1" BSPM standard valve	65/XXXXX
1" BSPM with vent button	65B/XXXXX
1" BSPM with vent button & TIR	65BT/XXXXX
1" BSPM with vent button & ventlock	68/XXXXX
1" BSPF standard valve	66/XXXXX
1" BSPF with vent button & ventlock	69/XXXXX
1" NPT standard valve	65/XXXXXNPT

NOTE: The valve specification changes the part number

Related Parts

Description	Part No.
1" BSP weld-in socket	600/1025
1" BSP weld-in nipple	600/1026
1" flame arrester	179/0300

Section View

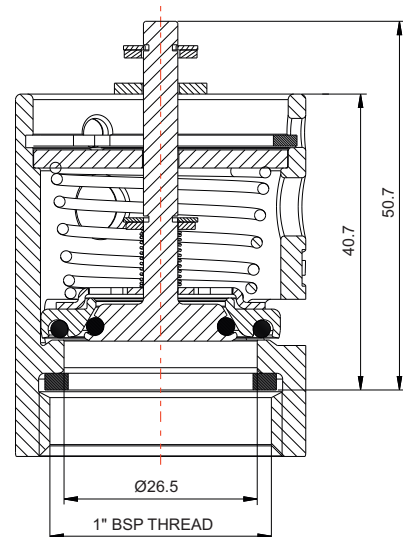
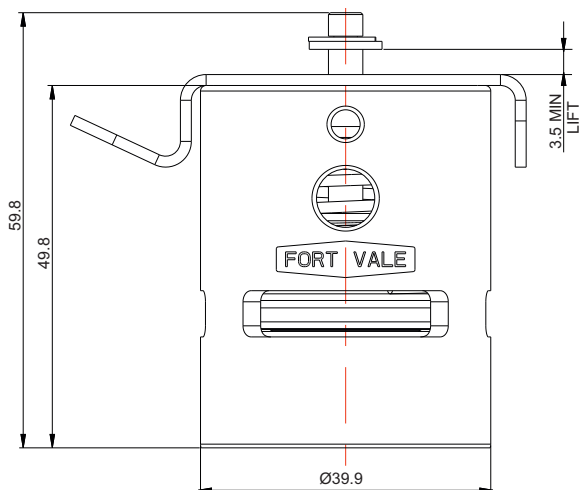



1" BSPF Minnow Ventlock Relief Valve - Pressure/Vacuum

Part No: 69/0XXXX

Parts Drawing

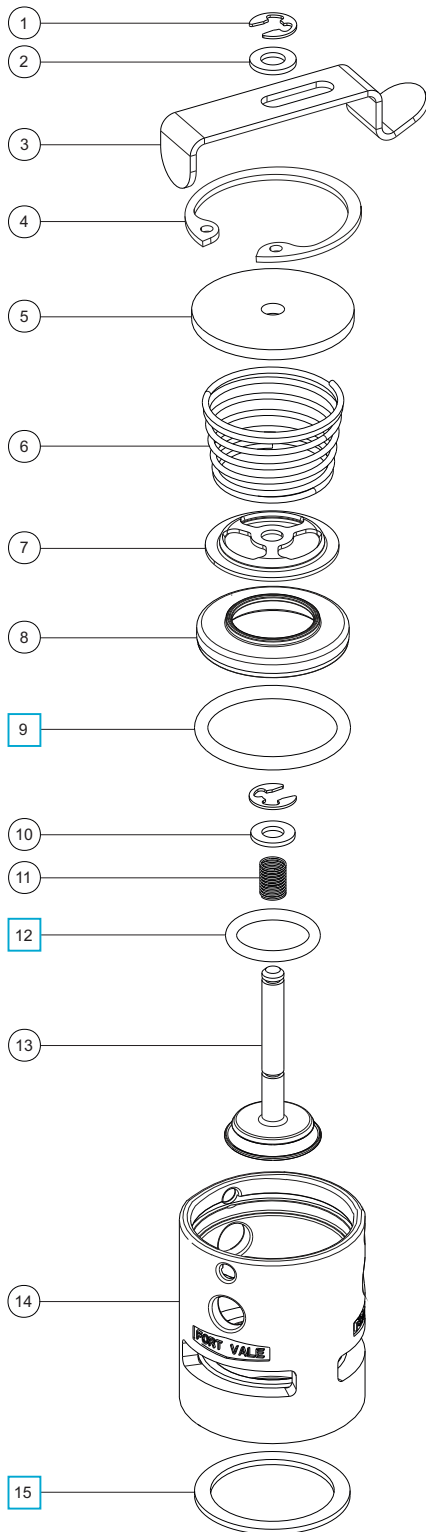

Parts List

Item	Description	Part No.
1	Circlip (2)	5120-002
2	Plain washer	5113-015
3	Ventlock bracket	179/0150
4	Retaining clip	5120-021
5	Top cap	179/0060
6	Pressure spring	Refer to Table 1
7	Poppet guide	179/0055
8	Pressure plate *Note	Refer to Table 2
9	Pressure O ring *Note	Refer to Table 2 <input type="checkbox"/>
10	Plain washer	5113-017
11	Vacuum spring	Refer to Table 3
12	Vacuum O ring	Refer to Table 4 <input type="checkbox"/>
13	Vacuum poppet	179/0090
14	Body	179/0200
15	PTFE seal	5005-660 <input type="checkbox"/>

NOTE: You will need special tools to install an O ring into a pressure plate. We recommend that you order a pressure plate/O ring assembly. Refer to Table 2.

Table 1

Std. Pressure Settings	Pressure Spring Part No.
3 PSI (0.21 Bar)	5104-653
6 PSI (0.41 Bar)	5104-656
9 PSI (0.62 Bar)	5104-659

Available settings: 1 PSI (0.07 Bar) to 9 PSI (3.10 Bar) max.

Table 2 - Refer to Note

Seal Material	Pressure O Ring	Pressure Plate/O Ring Assembly
EPDM	5005-651	179/0040ES
Perfluoroelastomer	5005-585	179/0040PERS
Viton	5005-552	179/0040VS

Table 3

Std. Vacuum Setting	Vacuum Spring Part No.
1"Hg (0.03 Bar)	5104-671

Available settings: 0.5"Hg (0.02 Bar) to 7"Hg (0.24 Bar)

Table 4

Seal Material	Vacuum O ring
EPDM	5005-652
Perfluoroelastomer	5005-586
Viton	20361

Seal Kit - All parts marked in the Parts List

Seal Material	Part No.
EPDM	66/9PVSK
Perfluoroelastomer	66/7PVSK
Viton	66/0PVSK



2" BSP Low Profile IBC Relief Valve - Pressure/Vacuum

Part No: 4B/XXXXXX



Specification

Nominal size

DN50

Tank connection

2" BSP

Set pressure

From 0.05 Bar to 1.00 Bar

Set vacuum

From 2 kPa to 17 kPa

Materials

Contact parts: 316 stainless steel

Pressure O ring: a selection of materials is available

Vacuum O ring: a selection of materials is available

Tank seal: Fortyt

Design Conditions

Weight: 0.58 Kg

For more Design Conditions, please contact Fort Vale and refer to the parts drawing.

Range

Description	Part No.
2" BSP valve: low profile body	4B/XXXXXX
2" BSP valve: standard body	4A/XXXXXX

Related Parts

Description	Part No.
2" BSP weld-in socket	600/1017
Installation C spanner	400/3000

Section View

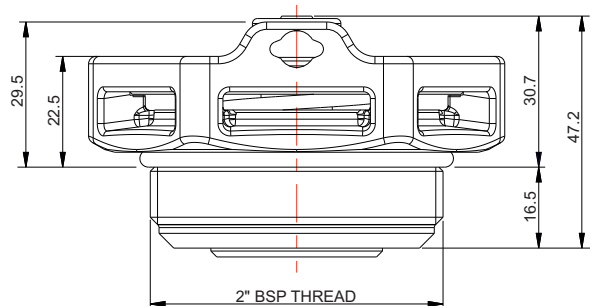
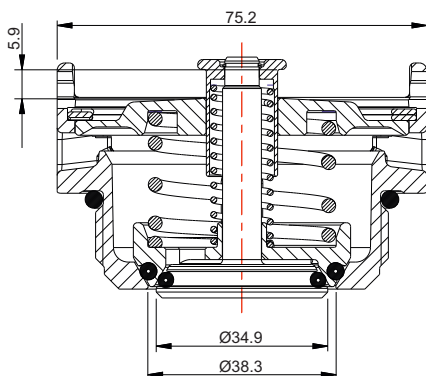



2" BSP Low Profile IBC Relief Valve - Pressure/Vacuum

Part No: 4B/XXXXXX

Parts Drawing

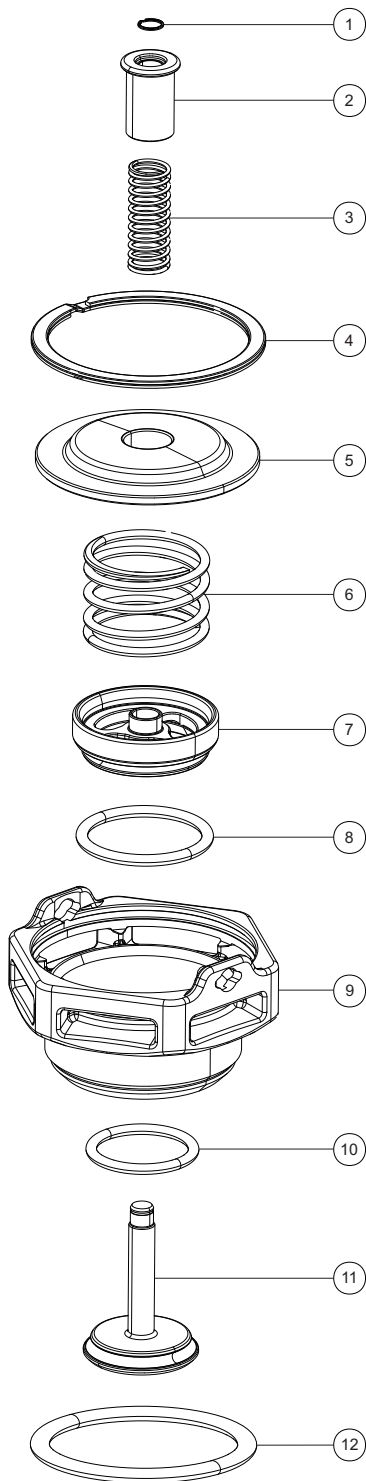

Parts List

Item	Description	Part No.
1	Retaining clip	5120-094
2	Vacuum spring guide *Note	175/0133/X
3	Vacuum spring *Note	5104-XXX
4	Retaining clip	5120-093
5	Top cap	175/0212
6	Pressure spring *Note	5104-XXX
7	Pressure plate	175/0216
8	Pressure O ring *Note	5005-372X
9	Body	175/0215
10	Vacuum O ring *Note	ORB215XX
11	Vacuum poppet	175/0214
12	Fortyt O ring	ORB228F0

NOTE: The valve specification changes the Part No.



2" BSP IBC Relief Valve - Pressure/Vacuum

Part No: 4A/XXXXXX



Specification

Nominal size

DN50

Tank connection

2" BSP

Set pressure

From 0.14 Bar to 1.00 Bar

Set vacuum

From 2 kPa to 30 kPa

Materials

Contact parts: 316 stainless steel

Pressure O ring: a selection of materials is available

Vacuum O ring: a selection of materials is available

Tank seal: Fortyt

Design Conditions

Weight: 1.00 Kg

For more Design Conditions, please contact Fort Vale and refer to the parts drawing.

Range

Description	Part No.
2" BSP valve: standard body	4A/XXXXXX
2" BSP valve: low profile body	4B/XXXXXX

Related Parts

Description	Part No.
2" BSP weld-in socket	600/1017
Installation C spanner	400/3000

Section View

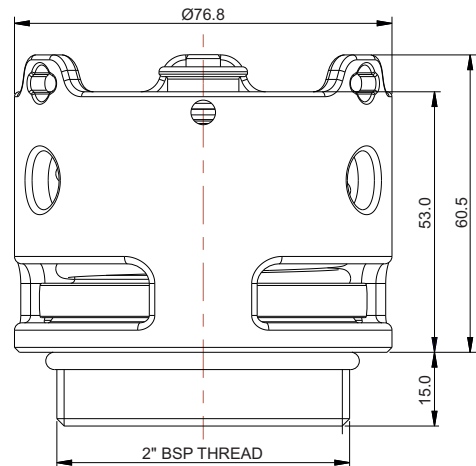
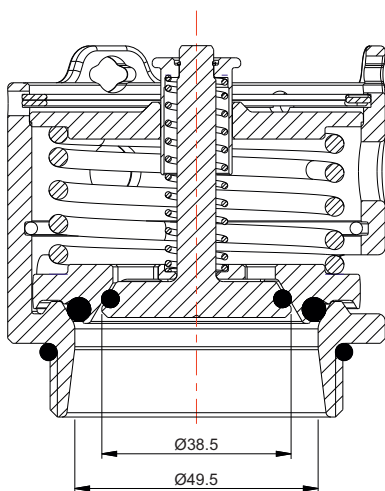



2" BSP IBC Relief Valve - Pressure/Vacuum

Part No: 4A/XXXXXX

Parts Drawing

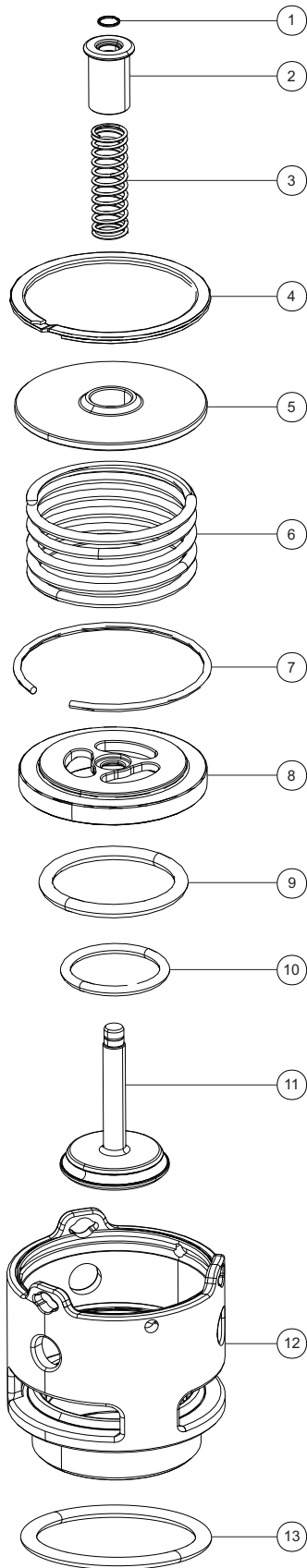

Parts List

Item	Description	Part No.
1	Retaining clip	5120-094
2	Vacuum spring guide *Note	175/0133/X
3	Vacuum spring *Note	5104-XXXX
4	Retaining clip	5120-093
5	Top cap	175/0132
6	Pressure spring *Note	5104-XXXX
7	Retaining ring clip	5120-041
8	Pressure plate	175/0131
9	Pressure O ring *Note	XXXXXXXXXX
10	Vacuum O ring *Note	5005-108XXX
11	Vacuum poppet	175/0134
12	Body	175/0130
13	Fortyt O ring	ORB228F0

NOTE: The valve specification changes the Part No.



Uniact Relief Valves

Design Options

Function

A relief valve is installed in the vapour space of a tank. It vents to protect the tank from accidental over-pressure or unwanted vacuum conditions. A Uniact relief valve is a single-acting valve. It is pre-set to give protection against pressure only or against vacuum only conditions.

We offer a range of relief valves for different service conditions and flow requirements. Contact us for more information.

Design Options

The design options below are available on our standard range of Uniact relief valves.

Tank Connection

Threaded: , 1½" BSP, 2" BSP

Flanged: 1½" ASA 150

Special service conditions:

Threaded: 1¼" BSP

DIN11851: 50mm, 65mm



Tank Seal

CNAF

Special service conditions:

PTFE

Nominal Bore

40mm (1½")

50mm (2")

Special service conditions:

32mm (1¼")

Pressure Setting

1½": From 0.05 Bar to 4.5 Bar

2": From 0.02 Bar to 4.15 Bar

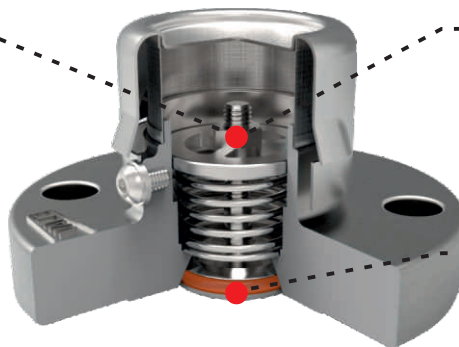

Vacuum Setting

1½": From 2 kPa to 88 kPa

2": From 2 kPa to 95 kPa

Pressure or Vacuum Seal

Fortyt

Special service conditions:

A range of elastomer seals is available

Valve Materials

316 stainless steel

Special service conditions:

Wetted parts in high nickel alloys



Ancillaries

Cowl

Gauze

Cap

Manual vent button (vacuum valve only)

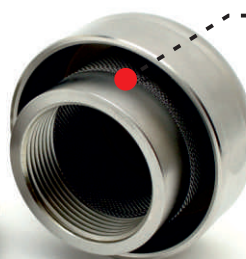



Uniact Relief Valves

Design Options

Related Parts

We recommend our range of compatible accessories:

- Cowl or cap - with or without gauze
- Weld-in sockets
- Weld-in flanges
- Gaskets
- Fasteners

Please contact us for more information about these parts.

Relief Valves for Dedicated Service

We offer a range of relief valves for these service conditions and special cargoes:

- T50 tank containers for liquefied gas
- Rail tank wagons
- U.S. tank trucks
- IBCs and small capacity tanks
- Steam-heating systems for tanks
- Hygienic service
- Food grade for liquid flow

Please contact us for more information about these valves.



1½” BSP Uniact Relief Valve - Pressure Only

Part No: 47/1XXX00AGZ - Metric Setting



Specification

Nominal size

DN40

Tank connection

1½” BSP

Set pressure

From 0.05 Bar to 4.50 Bar

Properties

With cowl and gauze

Materials

Contact parts: 316 stainless steel

Pressure O ring: Fortyt

Tank seal: CNAF

Alternatives are available, refer to the Design Options page

Design Conditions

Weight: 0.8 Kg
 Design Pressure (MAWP): 4.5 Bar
 Test Pressure: 7 Bar

For more Design Conditions, please contact Fort Vale and refer to the parts drawing.

Range

Description	Part No.
1½” BSP standard valve	47/XXXX00A
1½” BSP with cowl	47/XXXX00AC
1½” BSP with cowl and gauze	47/XXXX00AGZ
1½” BSP, alloy C276 contact parts	47H/XXXX00AX
1½” BSP with PTFE tank seal	47V/XXXX00AX
50mm DIN11851 connection	47M/XXXX00AX

NOTE: The valve specification changes the part no.

Related Parts

Description	Part No.
1½” weld-in socket	600/1010
50mm DIN11851 weld-in socket	176/2660
50mm DIN11851 fitting nut	176/2670
Installation C spanner	400/3000

Section View

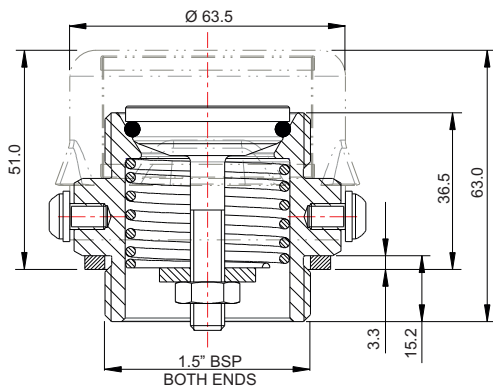



1½” BSP Uniact Relief Valve - Pressure Only

Part No: 47/1XXX00AGZ - Metric Setting

Parts Drawing

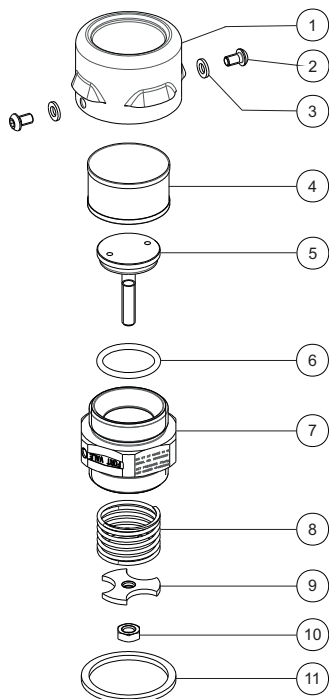

Parts List

Item	Description	Part No.
1	Cap	10217/1
2	M6 button screw (2)	5111-611
3	M6 spring washer (2)	5113-008
4	Gauze ring	10204
5	Poppet	10983V
6	Pressure O ring	Refer to Table 1
7	Body	10213
8	Spring	Refer to Table 2
9	Spring pad	10215
10	M8 half nut	5112-004
11	CNAF tank seal	5005-011

Table 1

O Ring Material	Part No.
Fortyt	5005-108H
High-temp. Fortyt	5005-108HPFA

Table 2

Std. Pressure Setting	Pressure Spring Part No.
2.05 Bar	5104-630

Available settings: 0.05 Bar to 4.50 Bar



1½” BSP Uniact Relief Valve - Vacuum Only

Part No: 47/1000XXAGZ - Metric Setting



Specification

Nominal size

DN40

Tank connection

1½” BSP

Set vacuum

From 2 kPa to 88 kPa

Properties

With cowl and gauze

Materials

Contact parts: 316 stainless steel

Vacuum O ring: Fortyt

Tank seal: CNAF

Alternatives are available, refer to the Design Options page

Design Conditions

Weight: 0.8 Kg
 Design Pressure (MAWP): 4.5 Bar
 Test Pressure: 7 Bar

For more Design Conditions, please contact Fort Vale and refer to the parts drawing.

Range

Description	Part No.
1½” BSP standard valve	47/X000XXA
1½” BSP with cowl	47/X000XXAC
1½” BSP with cowl and gauze	47/X000XXAGZ
1½” BSP with vent button	47/X000XXVBA
1½” BSP, alloy C276 contact parts	47H/X000XXAX
1½” BSP with PTFE tank seal	47V/X000XXAX
50mm DIN11851 connection	47M/X000XXAX

NOTE: The valve specification changes the part no.

Related Parts

Description	Part No.
1½” weld-in socket	600/1010
50mm DIN11851 weld-in socket	176/2660
50mm DIN11851 fitting nut	176/2670
Installation C spanner	400/3000

Section View

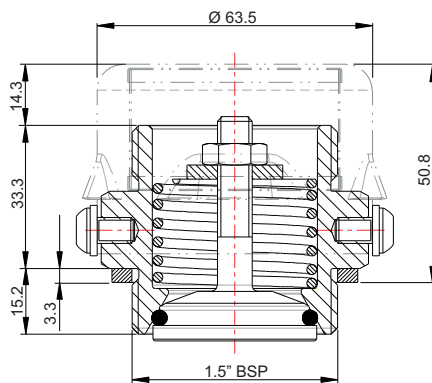



1½” BSP Uniact Relief Valve - Vacuum Only

Part No: 47/1000XXAGZ - Metric Setting

Parts Drawing

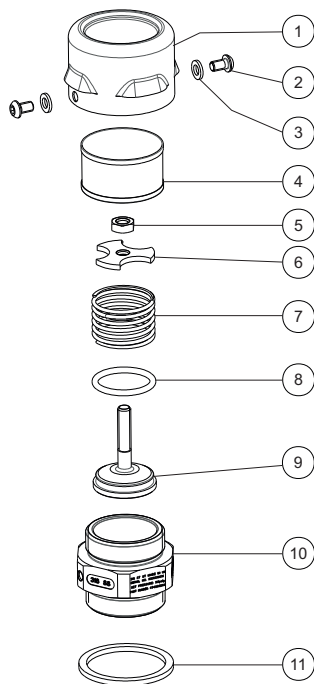

Parts List

Item	Description	Part No.
1	Cap	10217/1
2	M6 button screw (2)	5111-611
3	M6 spring washer (2)	5113-008
4	Gauze ring	10204
5	M8 half nut	5112-004
6	Spring pad	10215
7	Spring	Refer to Table 1
8	Vacuum O ring	Refer to Table 2
9	Poppet	10983V
10	Body	10213VO
11	CNAF gasket	5005-011

Table 1

Std. Vacuum Settings	Vacuum Spring Part No.
3 kPa	5104-601
20 kPa	5104-605

Available settings: 2 kPa to 88 kPa

Table 2

O Ring Material	Part No.
Fortyt	5005-108H
High-temp. Fortyt	5005-108HPFA



2" BSP Uniact Relief Valve - Vacuum Only

Part No: 85/1XXX00AX - Metric Setting



Specification

Nominal size

DN50

Tank connection

2" BSP

Set vacuum

From 2 kPa to 95 kPa

Materials

Contact parts: 316 stainless steel

Vacuum O ring: Fortyt

Tank seal: PTFE

Alternatives are available, refer to the Design Options page

Design Conditions

Weight:	1.4 Kg
Design Pressure (MAWP):	4.5 Bar
Test Pressure:	8.8 Bar

For more Design Conditions, please contact Fort Vale and refer to the parts drawing.

Range

Description	Part No.
2" BSP standard valve	85/XXXXXXA
2" BSP with cowl and gauze	85/XXXXXXAGZ
2" BSP, gauzed cap & vent button	85/X000XXVGA
65mm DIN11851 connection	85M/X000XXAX

Related Parts

Description	Part No.
2" BSP weld-in socket	600/1017
65mm DIN11851 socket	176/2645
65mm DIN11851 nut	176/2630
Cap with gauze	10218GZ
Cap with gauze & vent button	10218GZB
Cap - no gauze/vent button	10218
Installation C spanner	400/3000

Section View

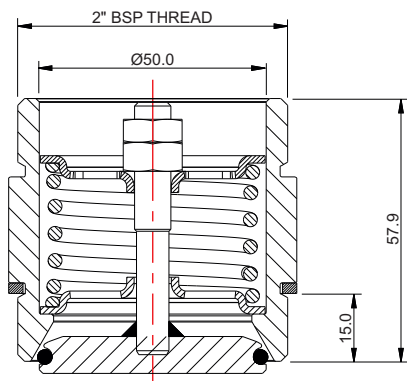



2" BSP Uniact Relief Valve - Vacuum Only

Part No: 85/1XXX00AX - Metric Setting

Parts Drawing

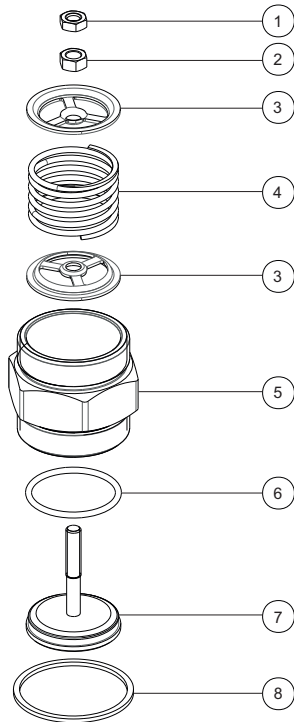

Parts List

Item	Description	Part No.
1	M8 half nut	5112-004
2	M8 full nut	5112-001
3	Spring pad (2) *Note	85/100X
4	Vacuum spring *Note	5104-XXX
5	Body	85/1000
6	Fortyt O ring	5005-118
7	Poppet	85/1015
8	PTFE tank seal	5005-575

NOTE: The valve specification changes the Part No.



Twinact Relief Valves

Design Options

Function

A relief valve is installed in the vapour space of a tank. It vents to protect the tank from accidental over-pressure or unwanted vacuum conditions. Twinact relief valves are pre-set to give protection against pressure only or against pressure and vacuum.

We offer a range of relief valves for different service conditions and flow requirements. Contact us for more information.

Design Options

The design options below are available on our standard range of Twinact relief valves.

Tank Connection

Threaded: 1½" BSP, 2½" BSP

Special service conditions:

Threaded: 1¼" BSP
DIN11851: 50mm, 80mm



Tank Seal

1½": CNAF

2½": Rubber/PTFE

Special service conditions:
Other materials are available

Nominal Bore

40mm (1½")

65mm (2½")

Special service conditions:
32mm (1¼")

Pressure Setting

From 0.05 Bar to 4.5 Bar

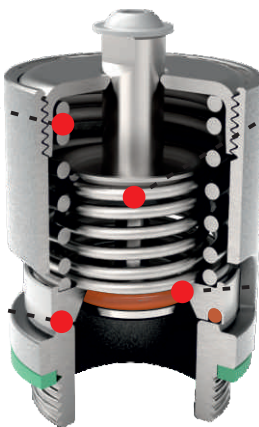

Vacuum Setting

From 1 kPa to 98 kPa

Pressure Seal

Fortyt

Special service conditions:

A range of seal materials is available

Vacuum Seal

Fortyt

Special service conditions:

A range of seal materials is available

Valve Materials

316 stainless steel

Special service conditions:

Wetted parts in high-nickel alloys





Twinact Relief Valves

Design Options

Related Parts

We recommend our range of compatible accessories:

- Flame arrester
- Weld-in sockets
- Flanges - weld-in and adaptor
- Gaskets

Please contact us for more information about these parts.

Relief Valves for Dedicated Service

We offer a range of relief valves for these service conditions and special cargoes:

- T50 tank containers for liquefied gas
- Rail tank wagons
- U.S. tank trucks
- IBCs and small capacity tanks
- Steam-heating systems for tanks
- Hygienic service
- Food grade for liquid flow

Please contact us for more information about these valves.



1½” BSP MK2 Twinact Relief Valve - Pressure Only

Part No: 3A/XXXX00 - Metric Setting



Specification

Nominal size
DN40

Tank connection
1½” BSP

Set pressure
From 0.05 Bar to 4.5 Bar

Materials
Contact parts: 316 stainless steel
Pressure O ring: Fortyt (Fig.1) or Viton (Fig.2)
Vacuum O ring: Fortyt (Fig.1) or Viton (Fig.2)
Tank seal: Rubber/PTFE envelope

Alternatives are available, refer to the Design Options page

Design Conditions

Weight: 0.84 Kg

For more Design Conditions, please contact Fort Vale and refer to the parts drawing.

WARNING: If you install an approved relief valve accessory item, e.g. a flame arrester, cowl, burst disc or baffle, it will decrease the air flow capacity of the relief valve. Thus, you must calculate again to make sure that the decreased air flow capacity will give sufficient protection to your vessel/system. Please refer to Fort Vale for more information.

Range

Description	Part No.
Standard valve - pressure/vacuum	3A/XXXXXX
Standard valve - pressure only	3A/XXXX00

NOTE: The valve specification changes the Part No.

Related Parts

Description	Part No.
1½” BSP weld-in socket	600/1010
1½” flame arrester *Warning	200/5000
PTFE tank seal	5005-012
Installation C spanner	400/3000

Section View

NOTE: The pressure plate is different for a Fortyt pressure O ring (Figure 1) and a Viton pressure O ring (Figure 2)

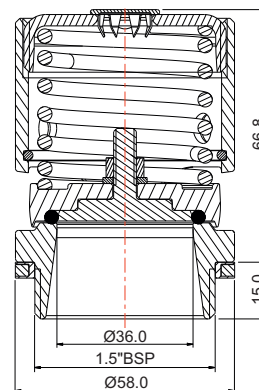
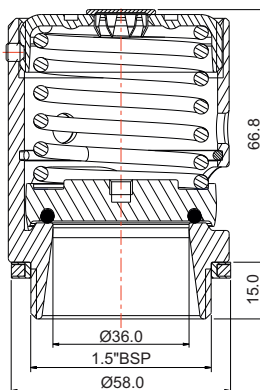

Figure 1. Valve with a Fortyt pressure O ring

Figure 2. Valve with a Viton pressure O ring



1½” BSP MK2 Twinact Relief Valve - Pressure Only

Part No: 3A/XXXX00 - Metric Setting

Parts Drawing

Figure 1: Fortyt pressure plate/O ring

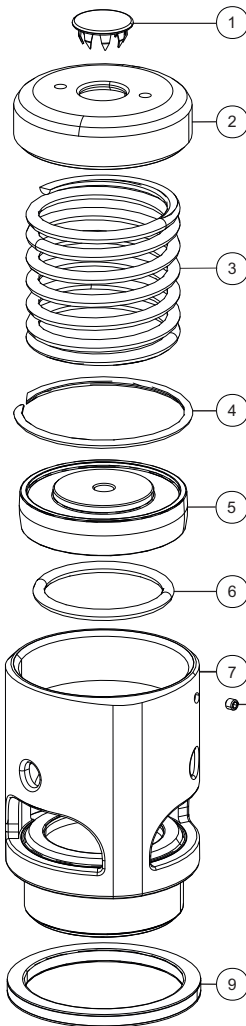
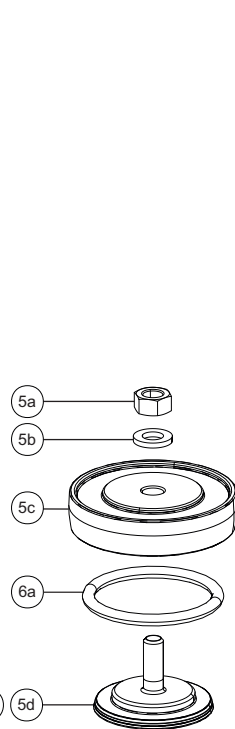

Figure 2: Viton pressure plate/O ring



Parts List

Item	Description	Part No.
1	Stainless steel plug	10978
2	Top cap	11004
3	Pressure spring	Refer to Table 1
4	Retaining ring clip	5120-070
5	Pressure plate for a Fortyt O ring *Note	175/X124 Refer to Table 2
5a-d	Composite pressure plate for a Viton O ring	110/0100X Refer to Table 3
6/6a	Pressure O ring *Note	Refer to Table 4
7	Body	11300
8	Anti-tamper screw	5121-001
9	Rubber/PTFE gasket	5005-006

NOTE: You will need special tools to install a Fortyt O ring into a pressure plate. We recommend that you order a pressure plate/O ring assembly. Refer to Table 2.

Table 1

Std. Pressure Setting	Pressure Spring Part No.
0.2 Bar	5104-0026
2 Bar	5104-0041

Available settings: 0.05 to 4.5 Bar

Table 2 - Refer to Note

O Ring Material	Pressure Plate Part No.	Pressure Plate/O Ring Assembly Part No.
Fortyt	175/0124	175/F124

Table 3

Item	Description	Part No.
5a	M6 full nut	5112-012
5b	M6 spring washer	5113-008
5c	Outer pressure plate	110/0100/1
5d	Inner pressure plate	110/0100/2

Table 4 - Refer to Note

Item	O Ring Material	Part No.
6	Fortyt	ORM0340400F0
6a	Viton	ORB220VR



1½” BSP MK2 Twinact Relief Valve - Pressure/Vacuum

Part No: 3A/XXXXXX - Metric Settings



Specification

Nominal size

DN40

Tank connection

1½” BSP

Set pressure

From 0.05 Bar to 4.5 Bar

Set vacuum

From 1 kPa to 98 kPa

Properties

With manual vent button

Materials

Contact parts: 316 stainless steel

Pressure O ring: Fortyt (Fig.1) or Viton (Fig.2)

Vacuum O ring: Fortyt (Fig.1) or Viton (Fig.2)

Tank seal: Rubber/PTFE envelope

Alternatives are available, refer to the Design Options page

Design Conditions

Weight: 0.78 Kg

For more Design Conditions, please contact Fort Vale and refer to the parts drawing.

WARNING: If you install an approved relief valve accessory item, e.g. a flame arrester, cowl, burst disc or baffle, it will decrease the air flow capacity of the relief valve. Thus, you must calculate again to make sure that the decreased air flow capacity will give sufficient protection to your vessel/system. Please refer to Fort Vale for more information.

Range

Description	Part No.
Standard valve - pressure/vacuum	3A/XXXXXX
Standard valve - pressure only	3A/XXXX00

NOTE: The valve specification changes the Part No.

Related Parts

Description	Part No.
1½” BSP weld-in socket	600/1010
1½” flame arrester *Warning	200/5000
PTFE tank seal	5005-012
Installation C spanner	400/3000

Section View

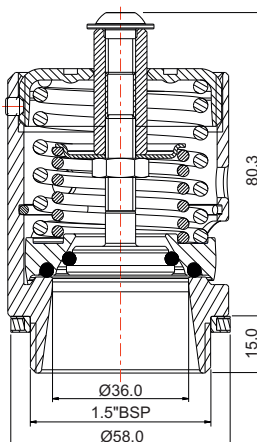



1½” BSP MK2 Twinact Relief Valve - Pressure/Vacuum

Part No: 3A/XXXXXX - Metric Settings

Parts Drawing

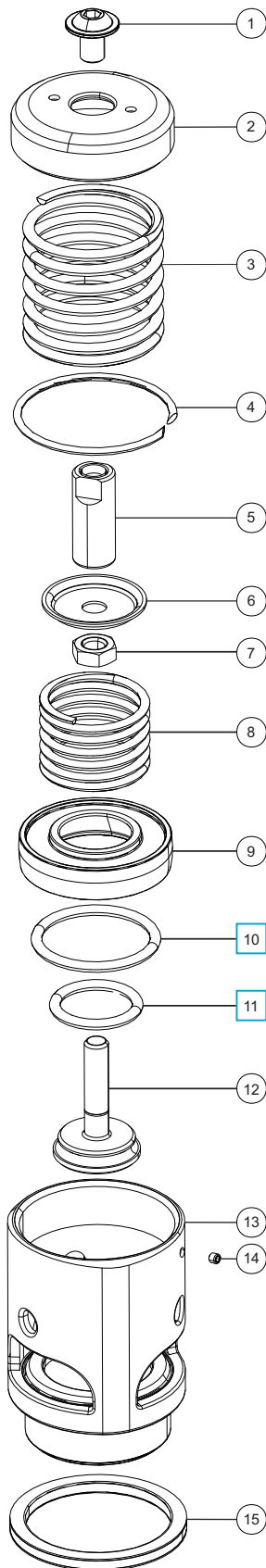

Parts List

Item	Description	Part No.
1	Flanged button screw	5111-9812
2	Top cap	11004
3	Pressure spring	Refer to Table 1
4	Retaining ring clip	5120-070
5	Spring stem	10984
6	Spring pad	11006
7	M8 half nut	5112-004
8	Vacuum spring	Refer to Table 2
9	Pressure plate *Note	Refer to Table 3
10	Pressure O ring *Note	Refer to Table 4 <input type="checkbox"/>
11	Vacuum O ring	Refer to Table 4 <input type="checkbox"/>
12	Vacuum poppet	11003
13	Body	11300
14	Anti-tamper screw	5121-001
15	Rubber/PTFE gasket	5005-006

NOTE: You will need special tools to install an O ring into a pressure plate. We recommend that you order a pressure plate/O ring assembly. Refer to Table 3.

Table 1

Std. Pressure Setting	Pressure Spring Part No.
0.2 Bar	5104-0026
2 Bar	5104-0041

Available settings: 0.05 to 4.5 Bar

Table 2

Std. Vacuum Setting	Vacuum Spring Part No.
2 kPa	5104-760
3 kPa	5104-761
10 kPa	5104-765

Available settings: 1 to 99 kPa

Table 3 - Refer to Note

O Ring Material	Pressure Plate Part No.	Pressure Plate/O Ring Assembly Part No.
Fortyt	175/0125	175/F125
Viton	175/0125	175/V125

Table 4 - Refer to Note

O Ring Material	Pressure O Ring Part No.	Vacuum O Ring Part No.
Fortyt	ORM0340400F0	5005-114
Viton	ORM0340400VR	5005-112

Seal Kit - All parts marked in the Parts List

Seal Material	Part No.
Fortyt	3A/1PVSK
Viton	3A/0PVSK



1½" Twinact Relief Valve 50mm DIN11851 - Pressure/Vacuum

Part No: 3M/1XXXX



Specification

Nominal size
DN40

Tank connection
50mm DIN11851

Set pressure
From 1 PSI to 64 PSI (0.07 Bar to 4.41 Bar)

Set vacuum
From 0.5"Hg to 28"Hg (0.02 Bar to 0.94 Bar)

Properties
With manual vent button

Materials
Contact parts: 316 stainless steel
Pressure O ring: Fortyt
Vacuum O ring: Fortyt

Alternatives are available, refer to the Design Options page

Design Conditions

Weight: 0.94 Kg

Seal Temperature Range:

Material	Min.Temp.°C	Max.Temp.°C
Fortyt	-55	200
Viton	-20	200

NOTE: The Design Conditions and Section View dimensions are for the specified part number only.

WARNING: If you install an approved relief valve ancillary item, such as a flame arrester, cowl, burst disc or baffle, it will decrease the air flow capacity of the relief valve. Thus, you must calculate again to make sure that the decreased air flow capacity of the relief valve and ancillary item will give sufficient protection to your vessel/system. Refer to Fort Vale for more information.

Range

Description	Part No.
Standard valve - pressure/vacuum	3M/1XXXX
Standard valve - pressure only	3M/1XX00

NOTE: The valve specification changes the Part No.

Related Parts

Description	Part No.
50mm DIN11851 weld-in socket	176/2660
50mm DIN11851 slotted nut	176/2670
50mm DIN11851 silicone seal	176/2675S
1½" clamped flame arrester *Warning	200/5000
Installation C spanner	400/3000

Section View

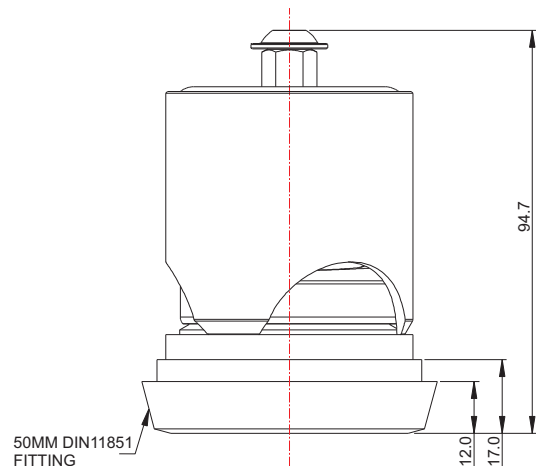
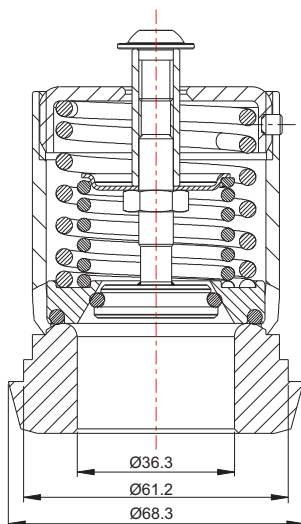



1½” Twinact Relief Valve 50mm DIN11851 - Pressure/Vacuum

Part No: 3M/1XXXX

Parts Drawing

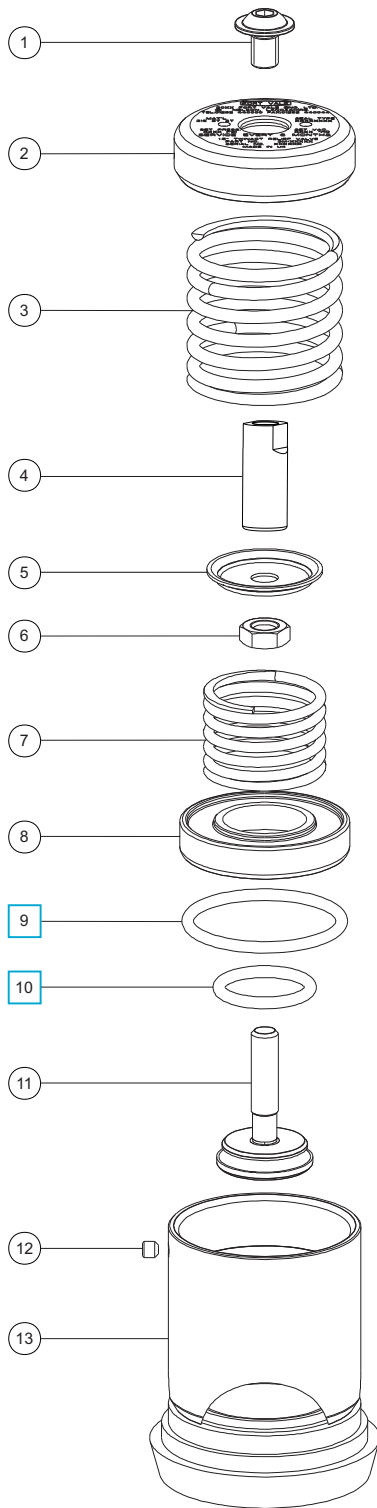

Parts List

Item	Description	Part No.
1	Flanged button screw	5111-9812
2	Top cap	11004
3	Pressure spring	Refer to Table 1
4	Spring stem	10984
5	Spring pad	11006XX
6	M8 half nut	5112-004
7	Vacuum spring	Refer to Table 2
8	Pressure plate *Note	Refer to Table 3
9	Pressure O ring *Note	Refer to Table 3 <input type="checkbox"/>
10	Vacuum O ring	Refer to Table 4 <input type="checkbox"/>
11	Vacuum poppet	11003
12	Anti-tamper screw	5121-001
13	Body	10990

NOTE: You will need special tools to install a pressure O ring into a pressure plate. We recommend that you order a pressure plate/O ring assembly. Refer to Table 3.

Table 1

Std. Pressure Settings	Pressure Spring Part No.
3 PSI (0.21 Bar)	5104-703
29 to 32 PSI (2.0 to 2.21 Bar)	5104-730

Pressure springs are available from 1 PSI (0.07 Bar) to 64 PSI (4.41 Bar)

Table 2

Std. Vacuum Setting	Vacuum Spring Part No.
0.5"Hg (0.02 Bar)	5104-760
1"Hg (0.03 Bar)	5104-761
3"Hg (0.10 Bar)	5104-765

Vacuum springs are available from 0.5"Hg (0.02 Bar) to 28"Hg (0.94 Bar)

Table 3

Seal Material	Pressure O Ring	Pressure Plate	Pressure Plate/O Ring Assembly
Fortyt	5005-118	11002XX	11002F
Viton	5005-110	11002XX	11002V

Table 4

Seal Material	Vacuum O Ring
Fortyt	5005-114
Viton	5005-112

Seal Kit

All parts marked in the Parts List

Seal Material	Part No.
Fortyt	30/1PVSK
Viton	30/0PVSK



2½” BSP MK2 Twinact Relief Valve - Pressure Only

Part No: 2A/XXXX00 - Metric Setting



Specification

Nominal size
DN65

Tank connection
2½” BSP

Set pressure
From 0.05 Bar to 4.5 Bar

Materials

Contact parts: 316 stainless steel
Pressure O ring: Fortyt (Fig.1) or Viton (Fig.2)
Vacuum O ring: Fortyt (Fig.1) or Viton (Fig.2)
Tank seal: Rubber/PTFE envelope

Alternatives are available, refer to the Design Options page

Design Conditions

Weight: 1.54 Kg

For more Design Conditions, please contact Fort Vale and refer to the parts drawing.

WARNING: If you install an approved relief valve accessory item, e.g. a flame arrester, cowl, burst disc or baffle, it will decrease the air flow capacity of the relief valve. Thus, you must calculate again to make sure that the decreased air flow capacity will give sufficient protection to your vessel/system. Please refer to Fort Vale for more information.

Range

Description	Part No.
Standard valve - pressure/vacuum	2A/XXXXXX
Standard valve - pressure only	2A/XXXX00

NOTE: The valve specification changes the Part No.

Related Parts

Description	Part No.
2½” BSP weld-in socket	600/1000
Tank weld-in flange	176/3150
2½” flame arrester *Warning	130/5000
CNAF tank seal	5005-026
Installation C spanner	400/3000

Section View

NOTE: The pressure plate is different for a Fortyt pressure O ring (Figure 1) and a Viton pressure O ring (Figure 2)

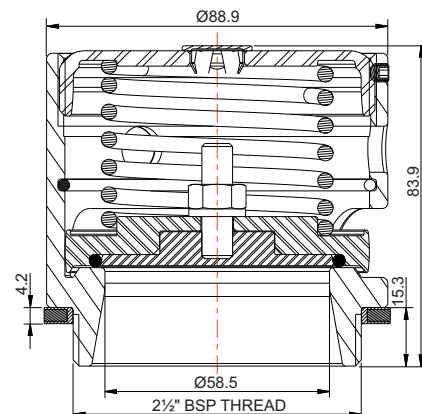
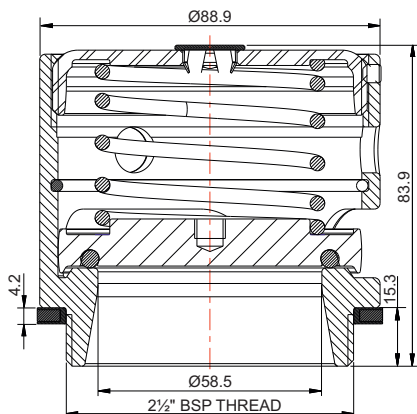

Figure 1. Valve with a Fortyt pressure O ring

Figure 2. Valve with a Viton pressure O ring



2 1/2" BSP MK2 Twinact Relief Valve - Pressure Only

Part No: 2A/XXXX00 - Metric Setting

Parts Drawing

Figure 1: Fortyt pressure plate/O ring

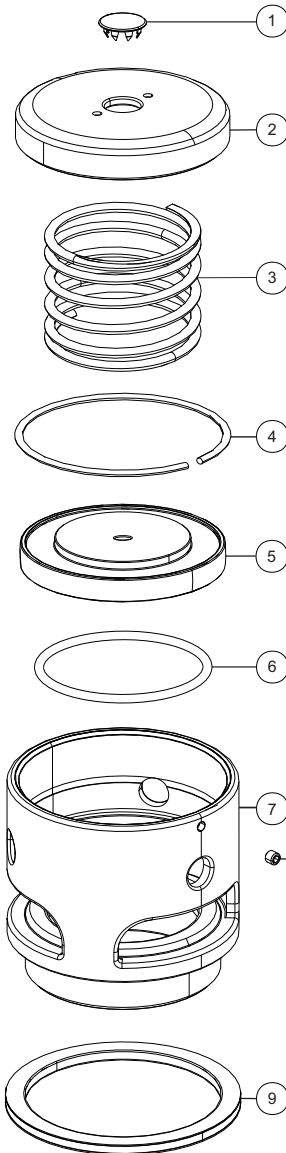
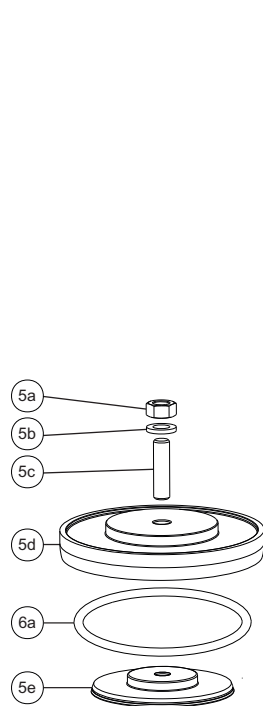

Figure 2: Viton pressure plate/O ring



Parts List

Item	Description	Part No.
1	Stainless steel plug	10978
2	Top cap	10967/1
3	Pressure spring	Refer to Table 1
4	Retaining ring clip	5120-071
5	Pressure plate for a Fortyt O ring *Note	175/X116 Refer to Table 2
5a-e	Composite pressure plate for a Viton O ring	175/X114 Refer to Table 3
6/6a	Pressure O ring *Note	Refer to Table 4
7	Body	10951/1
8	Anti-tamper screw	5121-001
9	Rubber/PTFE gasket	5005-046

NOTE: You will need special tools to install a Fortyt O ring into a pressure plate. We recommend that you order a pressure plate/O ring assembly. Refer to Table 2.

Table 1

Std. Pressure Setting	Pressure Spring Part No.
2 Bar	5104-0020

Available settings: 0.05 to 4.5 Bar

Table 2 - Refer to Note

O Ring Material	Pressure Plate Part No.	Pressure Plate/O Ring Assembly Part No.
Fortyt	175/0116	175/F116

Table 3

Item	Description	Part No.
5a	M8 full nut	5112-001
5b	M8 spring washer	5113-003
5c	M8 stud	11426
5d	Outer pressure plate	175/0114/1
5e	Inner pressure plate	175/0114/2

Table 4 - Refer to Note

Item	O Ring Material	Part No.
6	Fortyt	ORB330F0
6a	Viton	5005-313



2½” BSP MK2 Twinact Relief Valve - Pressure/Vacuum

Part No: 2A/XXXXXX - Metric Settings



Specification

Nominal size

DN65

Tank connection

2½” BSP

Set pressure

From 0.05 Bar to 4.5 Bar

Set vacuum

From 1 kPa to 98 kPa

Properties

With manual vent button

Materials

Contact parts: 316 stainless steel

Pressure O ring: Fortyt (Fig.1) or Viton (Fig.2)

Vacuum O ring: Fortyt (Fig.1) or Viton (Fig.2)

Tank seal: Rubber/PTFE envelope

Alternatives are available, refer to the Design Options page

Design Conditions

Weight: 1.59 Kg

For more Design Conditions, please contact Fort Vale and refer to the parts drawing.

WARNING: If you install an approved relief valve accessory item, e.g. a flame arrester, cowl, burst disc or baffle, it will decrease the air flow capacity of the relief valve. Thus, you must calculate again to make sure that the decreased air flow capacity will give sufficient protection to your vessel/system. Please refer to Fort Vale for more information.

Range

Description	Part No.
Standard valve - pressure/vacuum	2A/XXXXXX
Standard valve - pressure only	2A/XXXX00

NOTE: The valve specification changes the Part No.

Related Parts

Description	Part No.
2½” BSP weld-in socket	600/1000
Tank weld-in flange	176/3150
2½” flame arrester *Warning	130/5000
CNAF tank seal	5005-026
Installation C spanner	400/3000

Section View

NOTE: The pressure plate is different for a Fortyt pressure O ring (Figure 1) and a Viton pressure O ring (Figure 2)

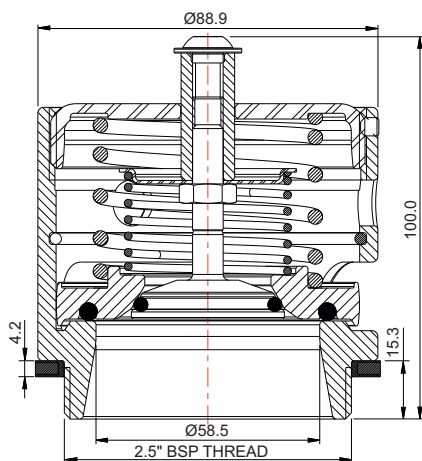

Figure 1. Valve with a Fortyt pressure O ring

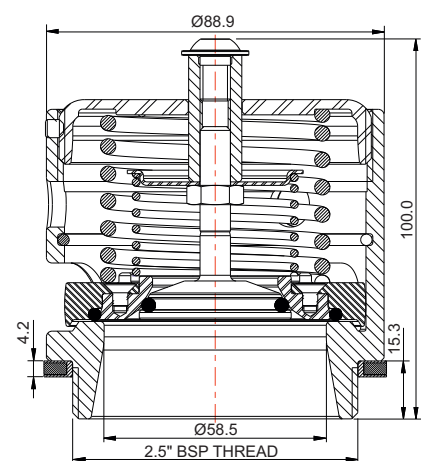

Figure 2. Valve with a Viton pressure O ring



2 1/2" BSP MK2 Twinact Relief Valve - Pressure/Vacuum

Part No: 2A/XXXXXX - Metric Settings

Parts Drawing

Figure 1: Fortyt pressure plate/O ring

Figure 2: Viton pressure plate/O ring

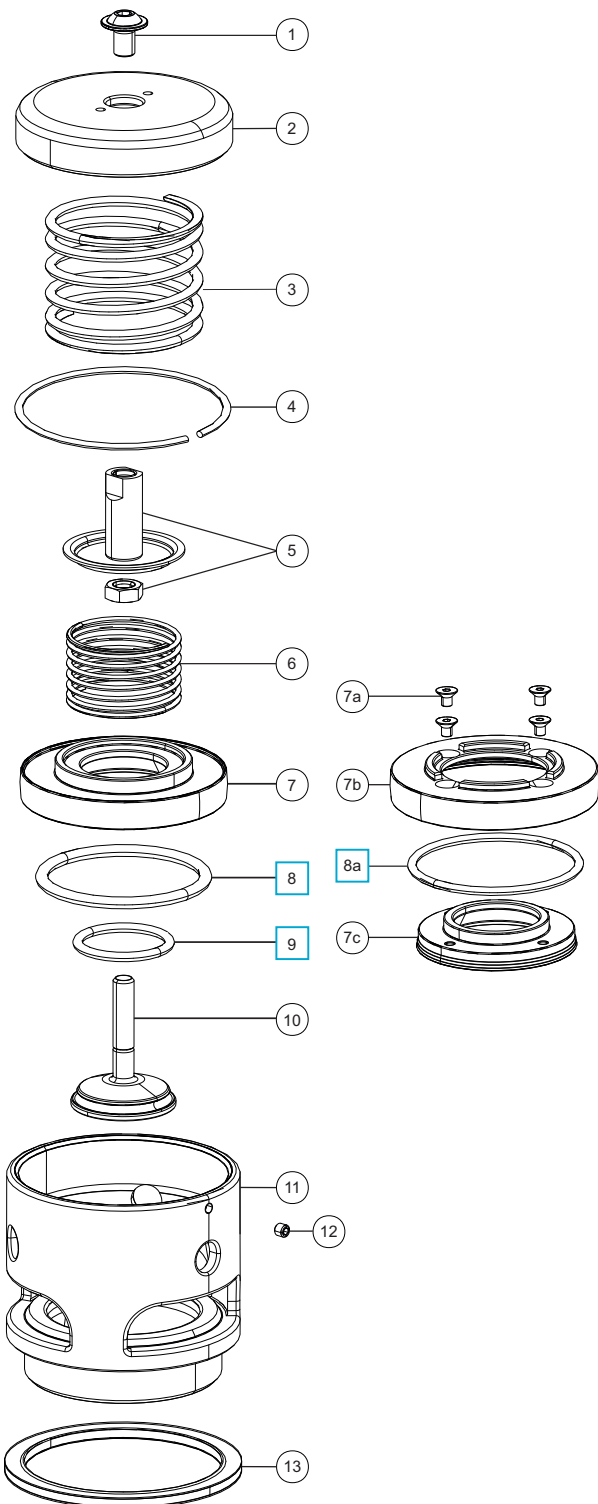

Parts List

Item	Description	Part No.
1	Flanged button screw	5111-9812
2	Top cap	10967/1
3	Pressure spring	Refer to Table 1
4	Retaining ring clip	5120-071
5	Spring pad assembly	130/0010
6	Vacuum spring	Refer to Table 2
7	Pressure plate for a Fortyt O ring *Note	Refer to Table 3
7a-c	Pressure plate for a Viton O ring	175/X260 Refer to Table 4
8/8a	Pressure O ring *Note	Refer to Table 5 <input type="checkbox"/>
9	Vacuum O ring	Refer to Table 5 <input type="checkbox"/>
10	Vacuum poppet	10983V
11	Body	10951/1
12	Anti-tamper screw	5121-001
13	Rubber/PTFE gasket	5005-046

NOTE: You will need special tools to install a Fortyt O ring into a pressure plate. We recommend that you order a pressure plate/O ring assembly. Refer to Table 3.

Table 1

Std. Pressure Setting	Pressure Spring Part No.
2 Bar	5104-0020

Available settings: 0.05 to 4.5 Bar

Table 2

Std. Vacuum Setting	Vacuum Spring Part No.
2 kPa	5104-560
3 kPa	5104-561
10 kPa	5104-563

Available settings: 1 to 99 kPa

Table 3 - Refer to Note

O Ring Material	Pressure Plate Part No.	Pressure Plate/O Ring Assembly Part No.
Fortyt	175/0117	175/F117

Table 4

Item	Description	Part No.
7a	M4 countersunk screw (4)	5111-310
7b	Outer pressure plate	175/0260/1
7c	Inner pressure plate	175/0260/2

Table 5 - Refer to Note

Item	O Ring Material	Pressure O Ring Part No.	Vacuum O Ring Part No.
8	Fortyt *Note	ORB330F0	5005-108H
8a	Viton	5005-313	5005-107

Seal Kit - All parts marked in the Parts List

Seal Material	Part No.
Fortyt	2A/1PVSK
Viton	2A/0PVSK



2½” Twinact Relief Valve - 80mm DIN11851, Pressure/Vacuum

Part No: 2M/1XXXX



Specification

Nominal size
DN65

Tank connection
80mm DIN11851

Set pressure
From 1 PSI to 63 PSI (0.07 Bar to 4.34 Bar)

Set vacuum
From 0.5"Hg to 28"Hg (0.02 Bar to 0.94 Bar)

Properties
With manual vent button

Materials
Contact parts: 316 stainless steel
Pressure O ring: Fortyt
Vacuum O ring: Fortyt

Alternatives are available, refer to the Design Options page

Design Conditions

Weight: 1.84 Kg

Seal Temperature Range

Material	Min.Temp.°C	Max.Temp.°C
Fortyt	-55	200
Viton	-20	200

NOTE: The Design Conditions and Section View dimensions are for the specified part number only.

WARNING: If you install an approved relief valve ancillary item, such as a flame arrester, cowl, burst disc or baffle, it will decrease the air flow capacity of the relief valve. Thus, you must calculate again to make sure that the decreased air flow capacity of the relief valve and ancillary item will give sufficient protection to your vessel/system. Refer to Fort Vale for more information.

Range

Description	Part No.
Standard valve - pressure/vacuum	2M/1XXXX
Standard valve - pressure only	2M/1XX00

NOTE: The valve specification changes the Part No.

Related Parts

Description	Part No.
80mm DIN11851 weld-in socket	176/2550
80mm DIN11851 fitting nut	176/2650
Silicone seal for DIN11851 socket	176/2685S
2½” flame arrester *Warning	130/5000
Installation C spanner	400/3000

Section View

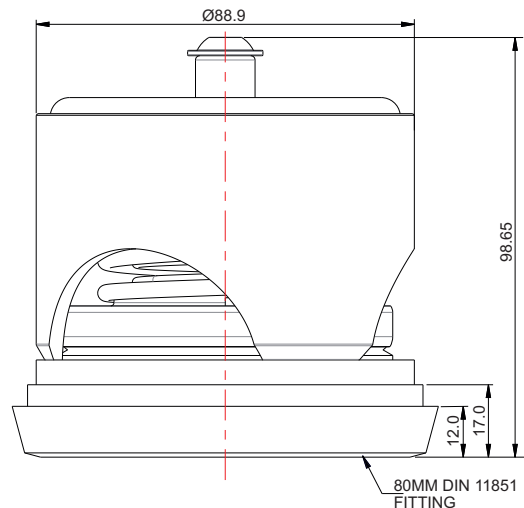
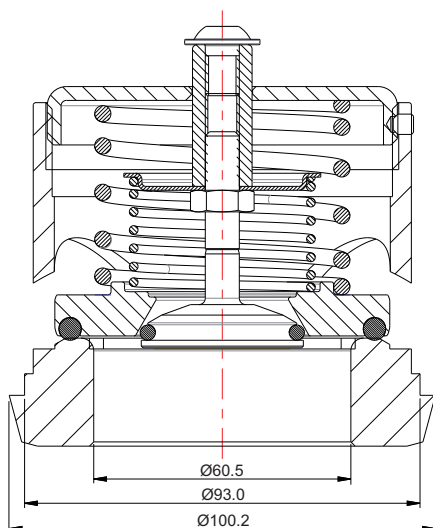



2 1/2" Twinact Relief Valve - 80mm DIN11851, Pressure/Vacuum

Part No: 2M/1XXXX

Parts Drawing

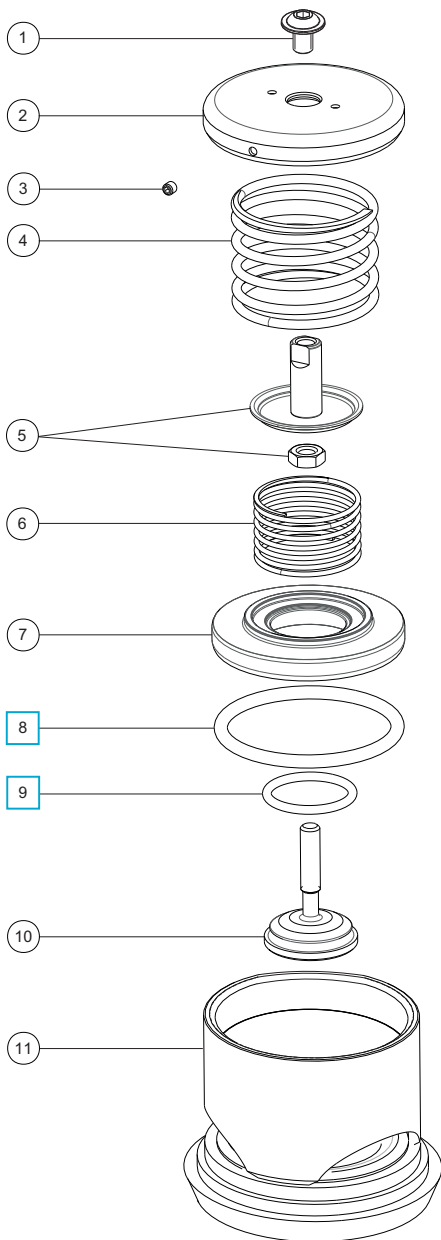

Parts List

Item	Description	Part No.
1	Flanged button screw	5111-9812
2	Top cap	10967/1
3	Anti-tamper screw	5121-001
4	Pressure spring	Refer to Table 1
5	Spring pad assembly	130/0010
6	Vacuum spring	Refer to Table 2
7	Pressure plate *Note	Refer to Table 3
8	Pressure O ring *Note	Refer to Table 3 <input type="checkbox"/>
9	Vacuum O ring	Refer to Table 4 <input type="checkbox"/>
10	Vacuum poppet	10983V
11	Body	11021

NOTE: You will need special tools to install a pressure O ring into a pressure plate. We recommend that you order a pressure plate/O ring assembly. Refer to Table 3.

Table 1

Std. Pressure Setting	Pressure Spring Part No.
28 to 30 PSI (1.93 to 2.07 Bar)	5104-529

Pressure springs are available from 1 PSI (0.07 Bar) to 63 PSI (4.34 Bar)

Table 2

Std. Vacuum Setting	Vacuum Spring Part No.
0.5"Hg (0.02 Bar)	5104-560
1"Hg (0.03 Bar)	5104-561
3"Hg (0.10 Bar)	5104-563

Vacuum springs are available from 0.5"Hg (0.02 Bar) to 28"Hg (0.94 Bar)

Table 3

Material	Pressure O Ring	Pressure Plate	Pressure Plate/O Ring Assembly
Fortyt	5005-101	175/0061	175/0061F
Viton	5005-102	175/0031	175/0031V

Table 4

Material	Vacuum O Ring
Fortyt	5005-108H
Viton	5005-107

Seal Kit

All parts marked in the Parts List

Seal Material	Part No.
Fortyt	20/1PVSK
Viton	20/0PVSK



Flame Arresters & Debris Protection for Relief Valves

Accessories & Spare Parts

Flame Arresters



Specification

A relief valve flame arrester attaches around the ports of the relief valve body. It prevents an external flame from being transmitted into the tank on relief valves with a vacuum setting of ≤ 0.21 Bar (6"Hg).

For relief valves with a vacuum setting of > 0.21 Bar (6"Hg), a flame arrester is frequently used to prevent debris from going into the tank through the relief valve.

Nominal sizes

Compatible with 1", 1½" 2½", 65mm and 80mm relief valves

Material

Stainless steel

WARNING: If you install a flame arrester, it will decrease the air flow capacity of the relief valve. Thus, you must calculate to make sure that the decreased air flow capacity of the relief valve and flame arrester will give sufficient protection to your vessel/system. Refer to Fort Vale for more information.

Flame Arresters

Each flame arrester is compatible for the specified relief valve type only. Flame arresters are not interchangeable between relief valve types.

IMPORTANT: Refer to the air flow decrease data for your valve type. (See **WARNING**)

Compatible Relief Valve	Air Flow Decrease	Part No.
1" Minnow	17% to 20%	179/0300
1½" Twinact	See Note	200/5000
2½" Twinact	See Note	130/5000
2½" & 65mm Super Maxi	1%	176/2900
80mm Hyper Maxi	5.4%	176/2920

NOTE: For the air flow decrease data for Twinact relief valves, please contact Fort Vale.

Debris Protection - Gauzed Cowl

Part No: 176/6000



Specification

A gauzed cowl attaches to the 65mm Super Maxi relief valve cap. It is used to prevent debris from going into the tank through the relief valve.

Nominal sizes

Compatible with a 65mm/2½" Super Maxi relief valve only

Material

Stainless steel

CAUTION: If you install a gauzed cowl onto a Super Maxi relief valve, it can decrease the relief valve air flow capacity. Refer to Fort Vale for more information.



Pressure Gauges

Accessories & Spare Parts

Standard Pressure Gauge



Tell-Tale Pressure Gauge



Specification

We supply standard pressure gauges and tell-tale pressure gauges. Tell-tale pressure gauges have a secondary pointer to indicate if there has been an increase in pressure, even if the pressure subsequently decreases.

All pressure gauges have a 1/4" BSP bottom connection and are glycerine filled.

Pressure range options

0-6 Bar, 0-10 Bar, 0-16 Bar

Material options - internal parts

Brass, stainless steel

Standard Pressure Gauge

Pressure Range Bar	Pressure Range PSI	Internal Parts	Part No.
0-6	0-90	Brass	921/06BBSP
0-6	0-90	St/steel	920/06BBSP
0-10	0-150	Brass	921/10BBSP
0-10	0-150	St/steel	920/10BBSP

Tell-Tale Pressure Gauge

Pressure Range Bar	Pressure Range PSI	Internal Parts	Part No.
0-6	0-90	Brass	921/06TTBBSP
0-6	0-90	St/steel	920/06TTBBSP
0-10	0-150	Brass	921/10TTBBSP
0-10	0-150	St/steel	920/10TTBBSP
0-16	0-230	St/steel	920/16TTBBSP



Weld-In Sockets for Relief Valves

Accessories & Spare Parts

Threaded Weld-In Sockets



Specification

Weld-in sockets are heavy-duty and have an oversized thread so that re-tapping after welding is not necessary

Nominal sizes

From DN15 to DN65

Thread sizes

From 1/2" BSP to 2 1/2" BSP

Material

316 stainless steel

If the type you need is not shown, please contact us

Weld-In Sockets

Nominal Size	Thread	Part No.
DN15	1/2" BSP	600/1030
DN20	3/4" BSP	653/1000
DN25	1" BSP	600/1025
DN40	1 1/2" BSP	600/1010
DN50	2" BSP	600/1017
DN65	2 1/2" BSP	600/1000

DIN11851 Weld-In Sockets



Specification

DIN11851 fittings are compatible with hygienic service conditions. A complete assembly includes a weld-in socket, a slotted nut and a silicone seal

Nominal sizes

DN50, DN65, DN80

Compatible parts

1 1/2", 2" and 2 1/2" relief valves

Material

Socket & nut: 316 stainless steel

Seal: Silicone

If the type you need is not shown, please contact us

DIN11851 Hygienic Fittings

Size	Weld Socket Part No.	Slotted Nut Part No.	Silicone Seal Part No.
DN50	176/2660	176/2670	176/2675S
DN65	176/2645	176/2630	176/2653S
DN80	176/2550	176/2650	176/2685S



Valve Repair and Maintenance Accessories & Spare Parts



We supply a range of special tools and repair kits to do scheduled maintenance and repair procedures to our valves.

We recommend that you use the correct special tools to help you do maintenance and repairs quickly and easily without causing damage to the valve or the new spare parts.

A selection of step-by-step maintenance instruction manuals is also available, please contact us.

CAUTION: Valve maintenance and repair can be dangerous. To do maintenance, you must have experience and qualifications related to valve installation on pressure vessels and systems.

Relief Valve Pressure/Vacuum Test Rig Part No: 400/8000



Specification

You can use the relief valve test rig to test the pressure and vacuum setting of Hyper Maxi, Super Maxi, Twinact, Uniact, Minnow and Steam relief valves.

Valve connection

2½" BSP.

We supply adaptors to change to other BSP and flanged connections.

Test rig supply connection

¼" BSP female socket

Test range

From -0.7 Bar to 6.9 Bar (-10 PSI to 100 PSI)

Related documents

Operating Instructions: OPIN26. Please contact us.

Footvalve & Relief Valve Seat Repair Kit Part No: 3" Kit - 400/2600 Part No: 4" Kit - 400/2900



Specification

You can use the seat repair kit to re-surface the seating face of a valve if there is damage caused by corrosion.

Compatible

3" Kit: compatible with 2½" Super Maxi relief valve and 3" Cleanflow and Highlift footvalves

4" Kit: compatible with 4" Cleanflow & Highlift footvalves

Connection

Compatible with power tools with a ½" chuck

Kit contents

Selection of grinding and polishing discs

Selection of face-forming tools

Instruction manual

Related documents

Operating Instructions: 3" Kit OPIN70, 4" Kit OPIN77.

Please contact us.

Spare Parts: Grinding Discs

Description	Part No. 3"	Part No. 4"
Box of 100 x 60 grit	400/2610	400/2615
Box of 100 x 80 grit	400/2620	400/2625
Box of 100 x 180 grit	400/2630	400/2635
Box of 100 x 500 grit	400/2640	400/2645



Valve Repair and Maintenance Accessories & Spare Parts



Relief Valve Tool Kits

Description	Part No.
Test rig adaptor flange - adapts 2½" BSP to 3" ASA150, DIN65 PN10 & DIN80 PN6	425/1000
C spanner - to install/remove Twinact relief valves	400/3000
C spanner - to install/remove Super Maxi relief valves	400/3001
Tightening tool for MKIII Super Maxi relief valves	400/8380
Tool kit - 1½" & 2½" Twinact valves	400/1000
Tool kit - 65mm & 80mm Super Maxi & Hyper Maxi relief valves	400/8300



Footvalve Tool Kits

Description	Part No.
3" Cleanflow footvalve tool kit	400/2150
3" Highlift footvalve tool kit	400/2450



Ball Valve Tool Kits

Description	Part No.
1½" ball valve tool kit	400/2500
3" ball valve tool kit	400/2200

Butterfly Valve Tool Kits

Description	Part No.
2" butterfly valve tool kit	400/2300
3" butterfly valve tool kit	400/2700



APPENDIX

Installation & Operating Instructions

A Client Responsibilities - Valves & Accessories



Client Responsibilities - Valves & Accessories

Installation, Operation & Maintenance Instructions

Compatibility

Make sure that the function and technical specification of the valve/accessory is compatible with the vessel service conditions and the cargo. This includes, but is not limited to:

- dimensions
- pressure/vacuum setting
- air/gas/liquid flow capacity
- maximum allowable working pressure
- test pressure
- minimum/maximum design temperatures
- materials of construction.

Maintenance

Fort Vale valves and accessories have a long life if you use them correctly in compatible service conditions. It is not necessary to lubricate the parts, but we recommend that you obey the precautions that follow:

Visual checks at regular intervals:

1. Examine the valve to make sure there is no damage, wear or corrosion.
2. Examine the valve and adjacent area to make sure there is no leakage of cargo.
3. Examine the fasteners to make sure they are not loose.
4. Make sure the valve operates correctly.

CAUTION: If you operate the valve with very corrosive cargo, or near its temperature and/or pressure limit (very high or very low temperature and/or pressure), do the visual checks more frequently.

As well as the visual checks, schedule suitable maintenance intervals for the valve based on how frequently the valve is used, the type of cargo and the service conditions.

After 2½ years of service, do the checks that follow:

1. Examine the valve to make sure there is no damage, wear or corrosion.
2. Make sure the valve operates correctly.
3. Do a pressure test on the valve.

After 5 years of service, do the checks that follow:

1. Disassemble and clean the valve.
2. Replace all the valve seals.

Replacement Parts

Do not adapt or change the valve. If you install a replacement part, it must be a genuine Fort Vale part.

WARNING: If you install a part that is not a genuine Fort Vale part, there is a risk of:

- injury to personnel
- permanent damage to the valve
- permanent damage to the vessel
- valve malfunction.

External Fire

If the valve is installed in an area where there is a risk of external fire, you must install compatible accessories to prevent damage to the valve.

Compatibility of Accessories

Accessory components must cause no interference with the valve function. Accessories must be made from compatible materials that will cause no damage to the valve materials. Do not install an accessory that will cause an increased load on the valve, i.e. mechanical, static, dynamic, thermal.

Mis-use

Obey the instructions and recommended procedures in the installation and operating instructions. Obey the pressure and temperature markings on the valve and on the drawing. Use the valve/accessory for its correct function only. Fort Vale accept no liability or responsibility for incorrect use of the valve/accessory.



Our subsidiaries are located in:

US Office

126 N. Virginia
La Porte
TX 77571
USA

Tel: +1 281 471 8100

Fax: +1 281 471 8116

Email: ussales@fortvale.com

Head Office

Calder Vale Park
Simonstone Lane
Simonstone, Burnley
Lancashire, BB12 7ND, UK

Tel: +44 (0) 1282 687120

Fax: +44 (0) 1282 687110

Email: sales@fortvale.com

China Office

Fort Vale Engineering Shanghai Ltd
Building 11 88 Yuanshan Road
Xinzhuang Industry Park
Shanghai 201108 China

Tel: +86 21 6442 1367

Fax: +86 21 6442 1376

Email: cnsales@fortvale.com

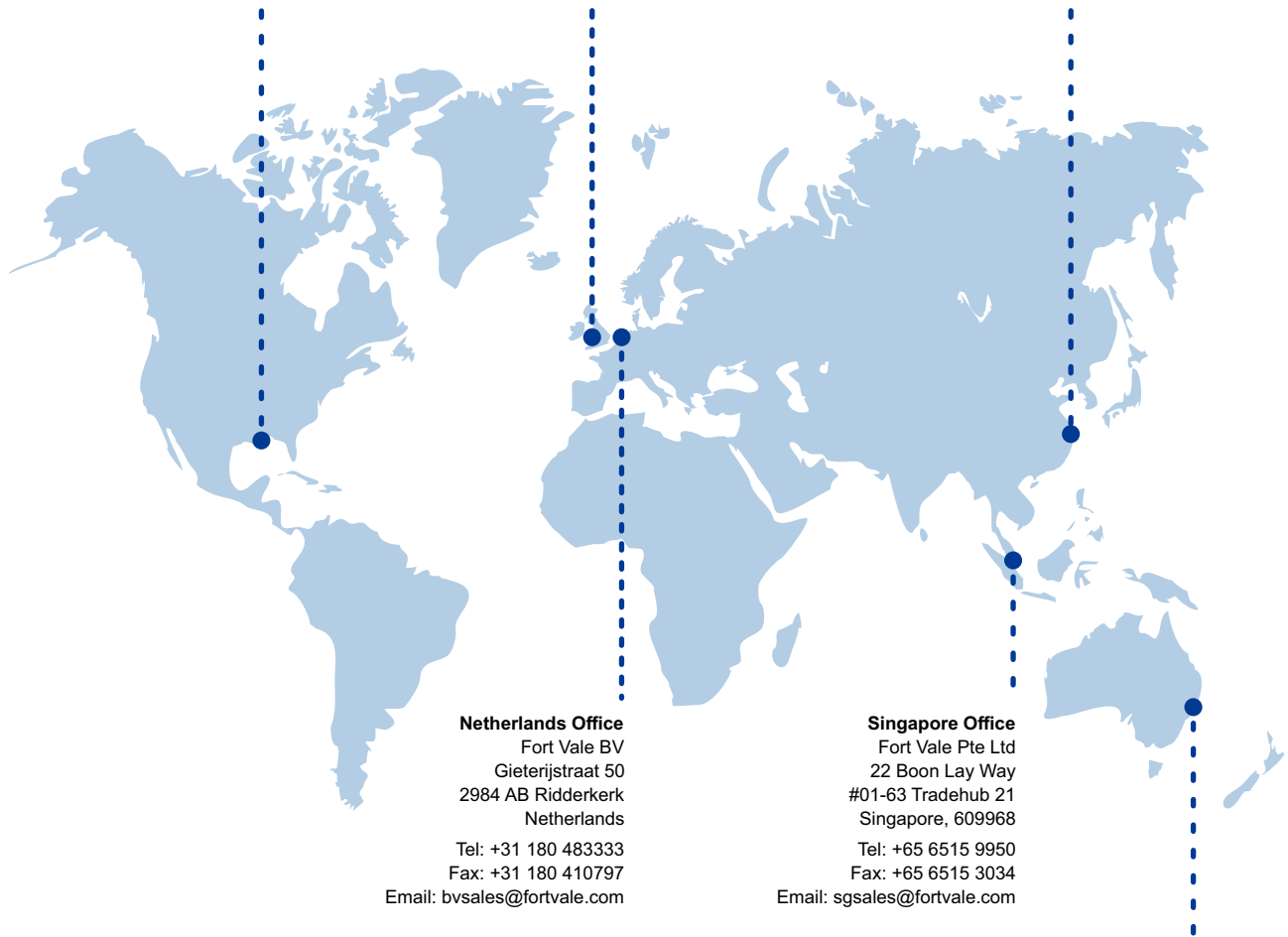

Netherlands Office

Fort Vale BV
Gieterijstraat 50
2984 AB Ridderkerk
Netherlands

Tel: +31 180 483333

Fax: +31 180 410797

Email: bvsales@fortvale.com

Singapore Office

Fort Vale Pte Ltd
22 Boon Lay Way
#01-63 Tradehub 21
Singapore, 609968

Tel: +65 6515 9950

Fax: +65 6515 3034

Email: sgsales@fortvale.com

Australia Office

Fort Vale Australia Pty Ltd
Bellwood Business Park
Unit 14, 49 Bellwood Street
Darra, Queensland, 4076

Tel: +61 7 3189 5059

Email: ausales@fortvale.com

We also have Authorised Distributors around the world to provide you with product sales and after-market services. To find your nearest distributor, please visit our website - www.fortvale.com

