



Catalogue

Standard Range of Footvalves



CONTENTS

Footvalves

Catalogue

Design Options: Footvalves	3
Cleanflow Footvalves	
3" 30° Cleanflow Footvalve	5
3" 45° Cleanflow Footvalve	7
3" 90° Cleanflow Footvalve	9
3" 180° Cleanflow Footvalve	11
4" 90° Cleanflow Footvalve - Pneumatically Actuated	13
6" 180° Cleanflow Footvalve - Hydraulically Actuated	15
Highlift Footvalves	
3" 30° Highlift Footvalve	17
3" 45° Highlift Footvalve	19
3" 90° Tankstream Footvalve	21
4" 45° Highlift Footvalve - Hydraulically Actuated	23
Composite Discharge Valve Assemblies	
3" 45° Uniflow Bottom Discharge Assembly	25
3" 45° Univalve Bottom Discharge Assembly	29

Continued over



CONTENTS

Footvalves

Catalogue

Accessories & Spare Parts

Footvalve Replaceable Seat Kit - Cleanflow Footvalve	33
Footvalve Replaceable Seat Kit - Highlift Footvalve	34
Valve Repair & Maintenance	35

Appendix

Bolt Torque Guide & Step Loading Procedure	39
Client Responsibilities	41
Fort Vale Worldwide	43



Footvalves

Design Options

Function

A footvalve is a primary closure valve that is installed at the drain point of a tank. It is used to load and discharge cargo in combination with a secondary closure valve. The footvalve body has a shear groove. To prevent leakage if there was an accident, the groove will break and keep the internal part of the valve closed and attached to the tank.

In our standard range, we offer two main types of footvalve; Cleanflow and Highlift.



Cleanflow

The Cleanflow footvalve does not protrude into the tank. When the valve is open, the poppet does not obstruct the discharge orifice, so the cargo discharges faster.



Highlift

The Highlift footvalve has a traditional internal cage and a spring-loaded poppet with a lifting finger.

Design Options

The design options below are available on our standard range of Cleanflow and Highlift footvalves.

Nominal Bore

80mm (3")

100mm (4")

Special service conditions:

125mm (5")

150mm (6")

Reduced bore: 80mm to 50mm
(3" to 2")



Body Style

Angle between the inlet & outlet flange

30°

45°

90°

180°

Special service conditions:

105° - Cleanflow only

Outlet Flange

Round and square flanges

4, 6 and 8 hole drilling patterns

Flats milled top and bottom



Operation

Manually operated: A range of handles is available

Pneumatically actuated

Hydraulically actuated

Main Seal

Fortyt

Special service conditions:

A range of seal materials is available

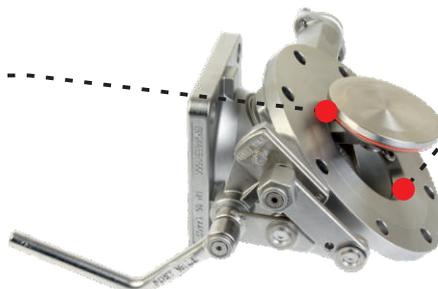

Inlet/Seat Area

Superseat: Alloy 625 integral seat

Special service conditions:

Replaceable seat:

High nickel alloy, e.g. Alloy C276,
904L stainless steel or
special metals, e.g. Titanium GR2

Design Options - continued

Valve Materials

316 stainless steel

Special service conditions:

Lined wetted parts, e.g. PFA, Halar ®

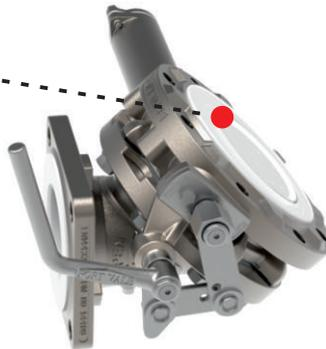

Special Cargoes

Solidifying cargo:

Body with steam-heating chamber

Conical poppet

Sensitive cargo:

Sample point



Composite Discharge Valve

A composite discharge valve is a combined primary and secondary closure valve. It saves space and reduces the number of joints between valves. Many of our design options are available on composite valves.

Please contact us for more information.

Related Parts

We recommend our range of compatible accessories:

- Remote closure systems and fusible elements
- Flanges - weld-in and adaptor
- Fasteners
- Gaskets

Please contact us for more information about these parts.

Footvalves for Dedicated Service

We offer a range of footvalves and discharge systems for these service conditions and special cargoes:

- Offshore fuel and chemical tanks
- T50 tank containers for liquefied gas
- Rail tank wagons
- Road tankers carrying hot product (bitumen)
- Road tankers: top operated screwdown valve

Please contact us for more information about these valves.



3" 30° Cleanflow Footvalve

Part No: 848/1000A

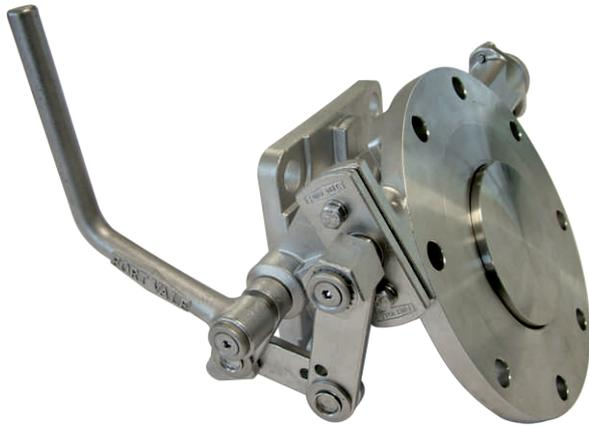

Specification

Nominal size/body angle

80mm / 30°

Inlet connection

Flanged: 8 x 14mm holes equi-spaced on a 178mm PCD

Outlet connection

Flanged: 4 x 17mm holes on a 160mm PCD

Materials

Contact parts: 316 stainless steel

Main seal: Fortyt

Alternatives are available, refer to the Design Options page

Design Conditions

Weight:	10.0 Kg
Design Pressure (MAWP):	4 Bar
Test Pressure:	6 Bar
Design Temperature Min:	-40°C
Design Temperature Max:	200°C

NOTE: The Design Conditions and Section View dimensions are for the specified part number only.

Design Codes

BS EN 14433

Range

Description	Part No.
With 4 hole outlet flange	848/1000A
With 6 hole outlet flange	848/0000A

Related Parts

Description	Part No.
Weld-in flange	324/9030
Stud kit	845/2040
CNAF/PTFE inlet gasket	5005-015
CNAF/PTFE outlet ring gasket	5005-049
CNAF/PTFE outlet gasket - 6 hole	5005-169
Valve operation decal	845/0320

Section View

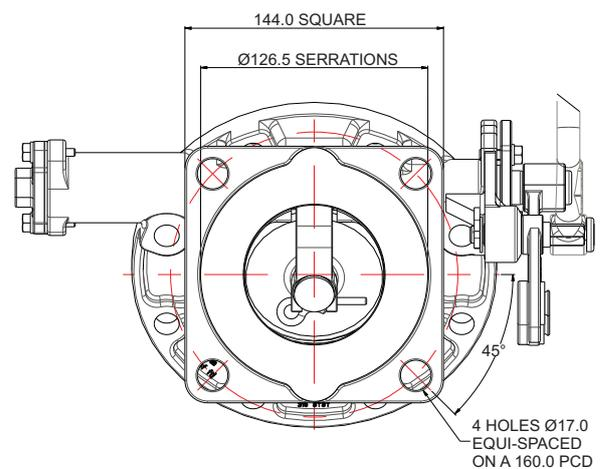
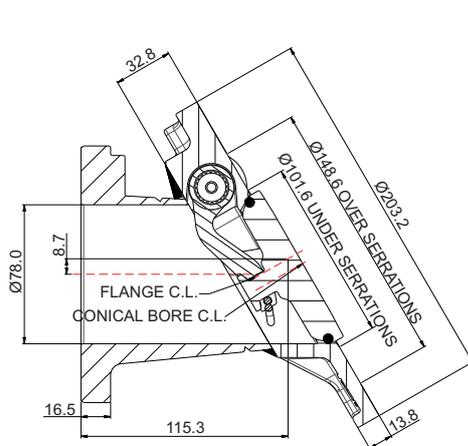



3" 30° Cleanflow Footvalve

Part No: 848/1000A

Parts Drawing

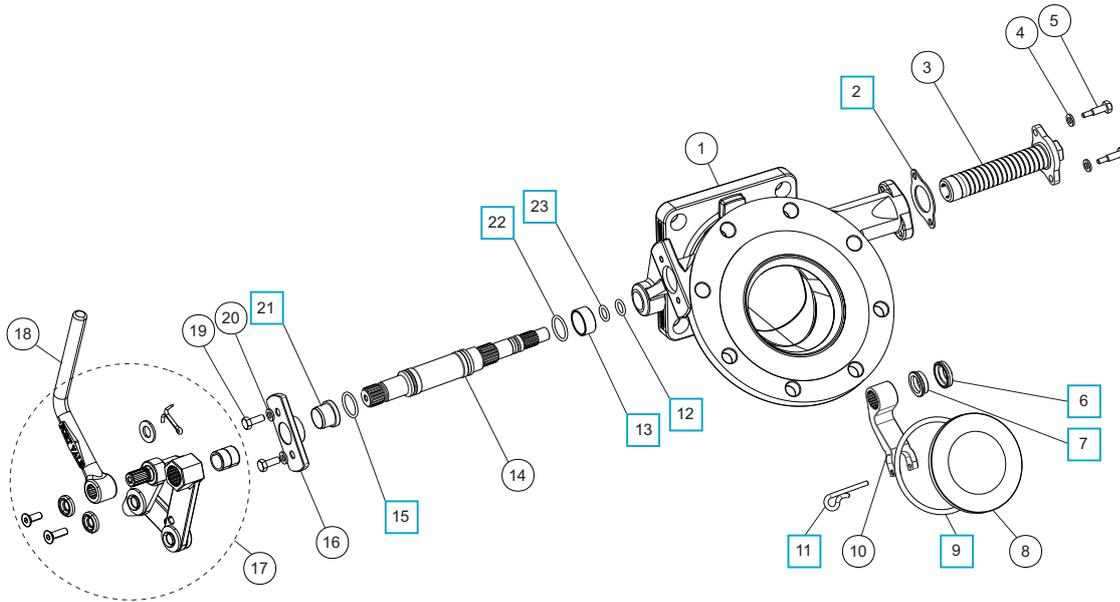

Parts List

Item	Description	Part No.	
1	Body	848/1100	
2	Spring boss gasket	5005-845	<input type="checkbox"/> <input type="radio"/>
3	Spring assembly	845/0050	
4	Spring washer (2)	5113-008	
5	Clamp screw (2)	845/0017	
6	Bush seal	845/0064	<input type="checkbox"/> <input type="radio"/>
7	Seal energizer	845/0063	<input type="checkbox"/> <input type="radio"/>
8	Poppet	845/0040	<input type="radio"/>
9	Fortyt O ring	5005-104	<input type="checkbox"/> <input type="radio"/>
10	Lifting fork	845/0010	<input type="radio"/>
11	Retaining pin	845/0015	<input type="checkbox"/> <input type="radio"/>
12	Perfluoroelastomer O ring	10133PHT	<input type="checkbox"/> <input type="radio"/>
13	Spindle bearing	845/0062	<input type="checkbox"/> <input type="radio"/>
14	Spindle	845/0200	<input type="radio"/>
15	Viton O ring	5005-336	<input type="checkbox"/> <input type="radio"/>
16	Stuffing clamp	845/0016	
17	Handle linkage assembly	324/8910	
18	Handle *Refer to Handle Options Table		
19	Clamp bolt (2)	5111-022	
20	Spring washer (2)	5113-008	
21	Stuffing seal	845/0061	<input type="checkbox"/> <input type="radio"/>
22	Perlast O ring	5005-384	<input type="checkbox"/> <input type="radio"/>
23	PTFE O ring	5005-008	<input type="checkbox"/> <input type="radio"/>

Footvalve Handle Options

Specification	Type	Part No.
Std. Cleanflow handle		324/8670
Cranked Cleanflow handle		324/8671
Std. Highlift handle		330/5010

Seal Kit

Description	Part No.
All parts marked <input type="checkbox"/> in the Parts List	845/00SK

Repair Kit

Description	Part No.
All parts marked <input type="radio"/> in the Parts List	845/00RK



3" 45° Cleanflow Footvalve

Part No: 845/1200A



Specification

Nominal size/body angle

80mm / 45°

Inlet connection

Flanged: 8 x 14mm holes equi-spaced on a 178mm PCD

Outlet connection

Flanged: 4 x 17mm holes on a 160mm PCD

Materials

Seating area: Superseat (alloy 625)

Contact parts: 316 stainless steel

Main seal: Fortyt

Alternatives are available, refer to the Design Options page

Design Conditions

Weight:	9.87 Kg
Design Pressure (MAWP):	4 Bar
Test Pressure:	6 Bar
Design Temperature Min:	-40°C
Design Temperature Max:	200°C

NOTE: The Design Conditions and Section View dimensions are for the specified part number only.

Approvals

BS EN 14433

Design Approval by Lloyds Register of Shipping

Range

Description	Part No.
Standard specification	845/1200A
With alloy C276 seating area	845/1200AHS

Related Parts

Description	Part No.
Weld-in flange	324/9000
Stud kit	845/2040
CNAF/PTFE inlet gasket	5005-015
CNAF/PTFE outlet ring gasket	5005-049
CNAF/PTFE outlet gasket - 6 hole	5005-169
Valve operation decal	845/0320

Section View

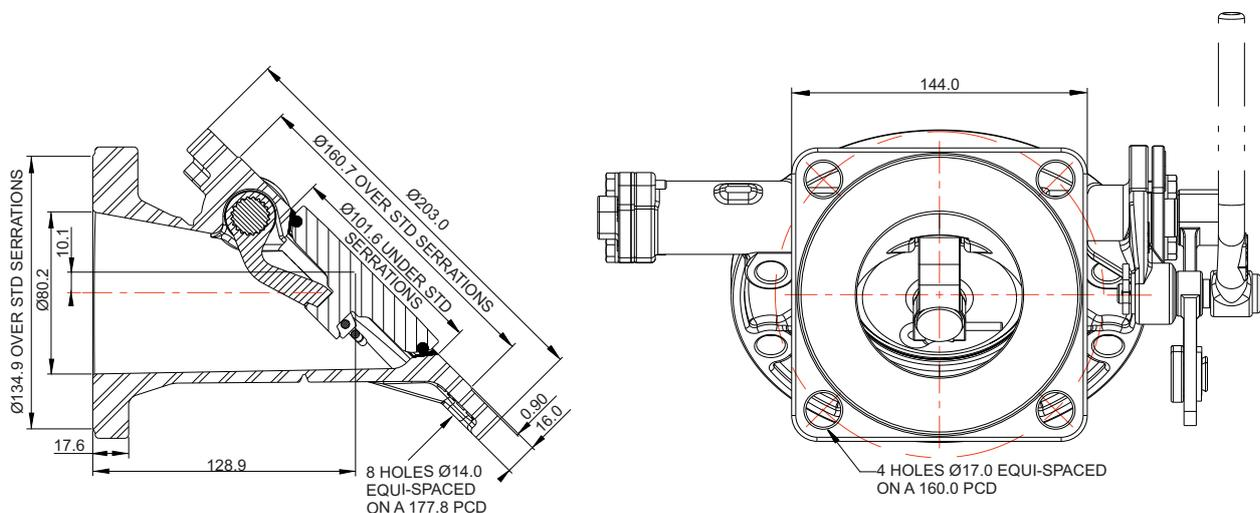



3" 45° Cleanflow Footvalve

Part No: 845/1200A

Parts Drawing

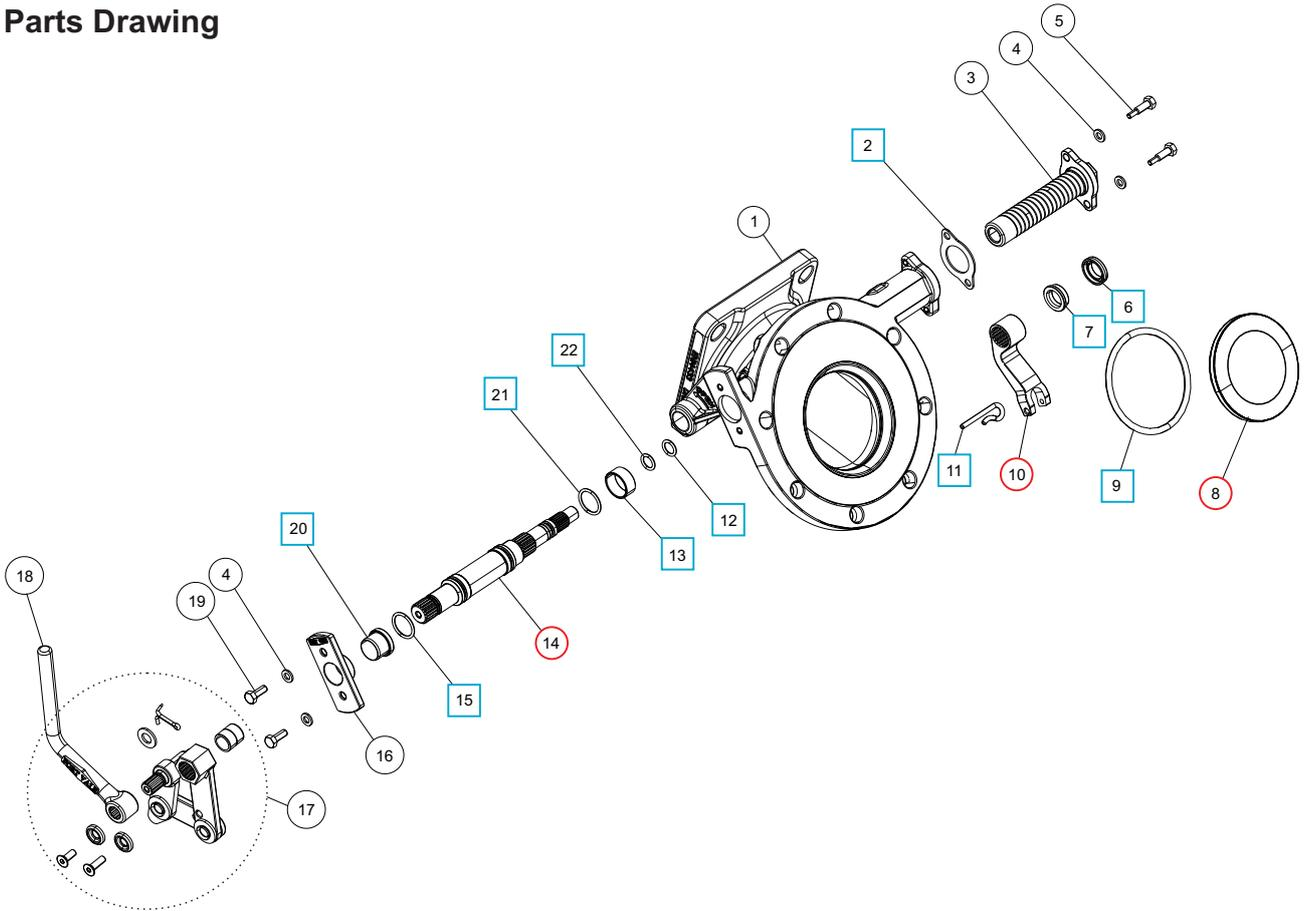

Parts List

Item	Description	Part No.	
1	Body	845/1100B	
2	Spring housing gasket	5005-845	□ ○
3	Spring assembly	845/0050	
4	M6 spring washer (4)	5113-008	
5	M6 hex bolt (2)	845/0017	
6	Bush seal	845/0064	□ ○
7	Seal energizer	845/0063	□ ○
8	Poppet	845/0040	○
9	Fortyt O ring	5005-104	□ ○
10	Lifting fork	845/0010	○
11	Retaining pin	845/0015	□ ○
12	Perlast O ring	10133PHT	□ ○
13	Spindle bearing	845/0062	□ ○
14	Spindle	845/0200	○
15	Viton O ring	5005-336	□ ○
16	Stuffing clamp flange	845/0016	
17	Handle linkage assembly	324/8910	
18	Handle *Refer to Handle Options Table		
19	M6 X 16mm hex bolt (2)	5111-022	
20	Stuffing seal	845/0061	□ ○
21	Perlast O ring	5005-384	□ ○
22	PTFE O ring	5005-008	□ ○

Footvalve Handle Options

Specification	Type	Part No.
Std. Cleanflow handle		324/8670
Cranked Cleanflow handle		324/8671
Std. Highlift handle		330/5010

Seal Kit

Description	Part No.
All parts marked □ in the Parts List	845/00SK

Repair Kit

Description	Part No.
All parts marked ○ in the Parts List	845/00RK



3" 90° Cleanflow Footvalve

Part No: 844/3000A



Specification

Nominal size/body angle

3" / 90°

Inlet connection

Flanged: 8 x 14mm holes on a 178mm PCD

Outlet connection

Flanged: 4 x 17mm holes on a 160mm PCD

Materials

Seating area: Superseat (alloy 625)

Contact parts: 316 stainless steel

Main seal: Fortyt

Alternatives are available, refer to the Design Options page

Design Conditions

Weight:	15.0 Kg
Design Pressure (MAWP):	4 Bar
Test Pressure:	7.3 Bar
Design Temperature Min:	-40°C
Design Temperature Max:	200°C

NOTE: The Design Conditions and Section View dimensions are for the specified part number only.

Design Codes

BS EN14433

Design Approval by Lloyds Register of Shipping

Range

Description	Part No.
Standard body, manually operated	844/3000A
Extended body, manually operated	844/7400A
Standard body, pneumatically actuated	844/3080ASS
Extended body, pneumatically actuated, slotted outlet	844/7700ASS

Related Parts

Description	Part No.
Weld-in flange	324/9000
Stud kit	Refer to drawing
CNAF/PTFE inlet gasket	5005-015
CNAF/PTFE ring gasket	5005-049
CNAF/PTFE 4 hole gasket with flats	5005-034
Mating flange	294/0081

Section View

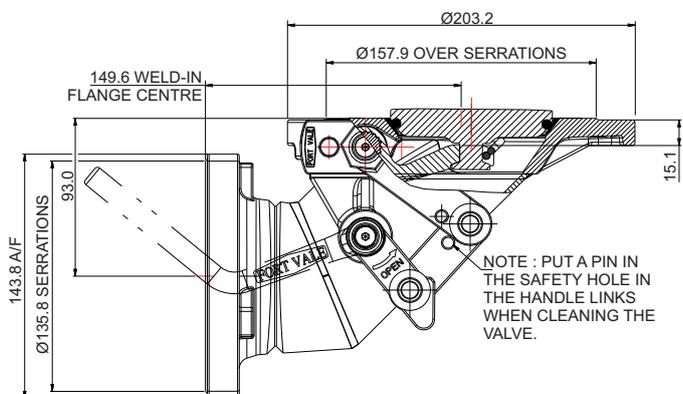
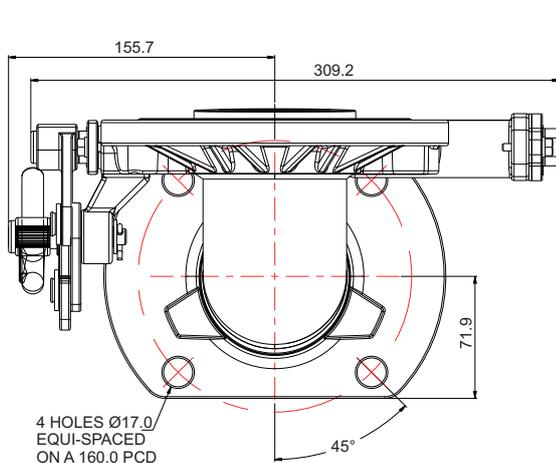



3" 90° Cleanflow Footvalve

Part No: 844/3000A

Parts Drawing

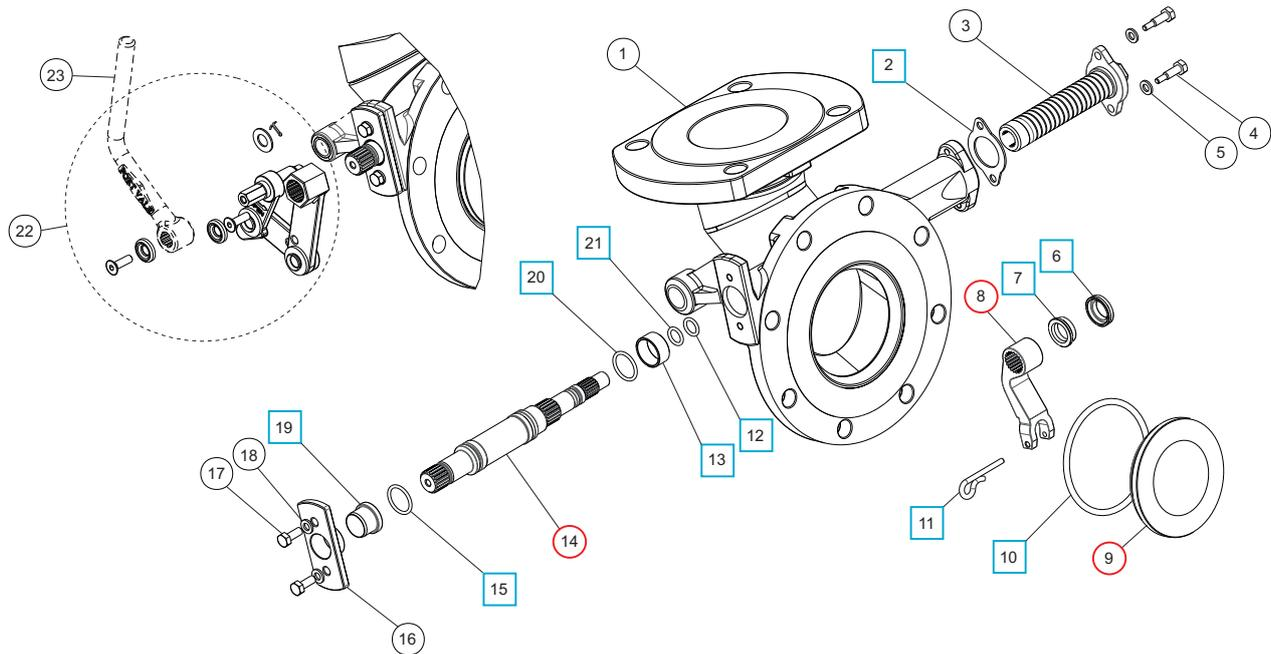

Parts List

Item	Description	Part No.
1	Body	844/2075B
2	Spring boss gasket	5005-845 <input type="checkbox"/> <input type="radio"/>
3	Spring assembly	845/0050
4	Clamp screw (2)	845/0017
5	Spring washer (2)	5113-008
6	Bush seal	845/0064 <input type="checkbox"/> <input type="radio"/>
7	Seal energizer	845/0063 <input type="checkbox"/> <input type="radio"/>
8	Lifting fork	845/0010 <input type="radio"/>
9	Poppet	845/0040 <input type="radio"/>
10	Fortyt O ring	5005-104 <input type="checkbox"/> <input type="radio"/>
11	Retaining pin	845/0015 <input type="checkbox"/> <input type="radio"/>
12	Perfluoroelastomer O ring	10133PHT <input type="checkbox"/> <input type="radio"/>
13	Spindle bearing	845/0062 <input type="checkbox"/> <input type="radio"/>
14	Spindle	845/0200 <input type="radio"/>
15	Viton O ring	5005-336 <input type="checkbox"/> <input type="radio"/>
16	Stuffing clamp	845/0016
17	Clamp bolt (2)	5111-022
18	Spring washer (2)	5113-008
19	Stuffing seal	845/0061 <input type="checkbox"/> <input type="radio"/>
20	Perlast O ring	5005-384 <input type="checkbox"/> <input type="radio"/>
21	PTFE O ring	5005-008 <input type="checkbox"/> <input type="radio"/>
22	Handle linkage assembly	324/8910
23	Handle *Refer to the Handle Options Table	

Footvalve Handle Options

Specification	Type	Part No.
Std. Cleanflow handle		324/8670
Std. Highlift handle		330/5010

Seal Kit

Description	Part No.
All parts marked <input type="checkbox"/> in the Parts List	845/00SK

Repair Kit

Description	Part No.
All parts marked <input type="radio"/> in the Parts List	845/00RK



3" 180° Cleanflow Footvalve

Part No: 840/0000A



Specification

Nominal size/body angle

80mm / 180°

Inlet connection

Flanged: 8 x 14mm holes equi-spaced on a 177.8mm PCD

Outlet connection

Flanged: 4 x 18mm holes on a 160mm PCD

Materials

Seating area: Superseat (alloy 625)

Contact parts: 316 stainless steel

Lifting fork: high nickel alloy

Main seal: Fortyt

Alternatives are available, refer to the Design Options page

Design Conditions

Weight:	9.7 Kg
Design Pressure (MAWP):	4 Bar
Test Pressure:	6 Bar
Design Temperature Min:	-40°C
Design Temperature Max:	200°C

NOTE: The Design Conditions and Section View dimensions are for the specified part number only.

Design Codes

BS EN 14433

BS EN 13445

Related Parts

Description	Part No.
Weld-in flange	324/9000
Stud kit	845/2040
CNAF/PTFE inlet gasket	5005-015

Section View

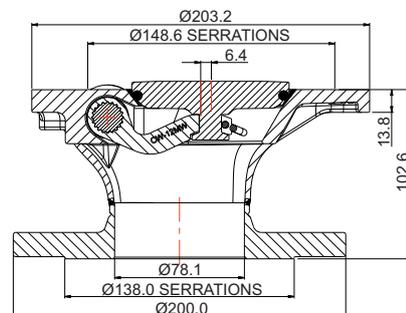
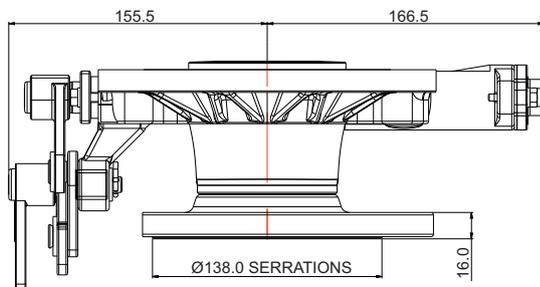



3" 180° Cleanflow Footvalve

Part No: 840/0000A

Parts Drawing

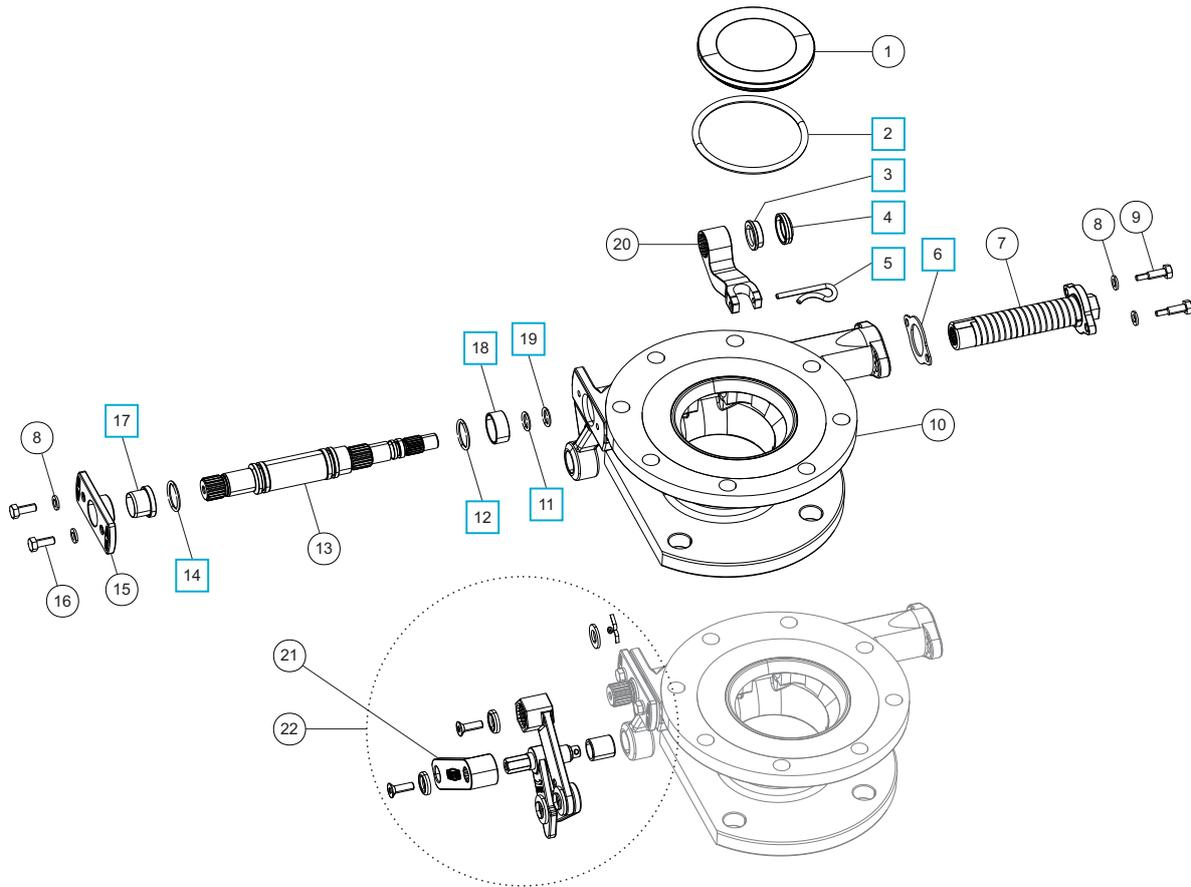

Parts List

Item	Description	Part No.
1	Poppet	845/0040
2	Fortyt O ring	5005-104 <input type="checkbox"/>
3	Seal energizer	845/0063 <input type="checkbox"/>
4	Bush seal	845/0064 <input type="checkbox"/>
5	Retaining pin	845/0015 <input type="checkbox"/>
6	PTFE spring housing gasket	5005-845 <input type="checkbox"/>
7	Spring assembly	845/0050
8	M6 spring washer (4)	5113-008
9	M6 hex bolt (2)	845/0017
10	Body	840/0110B
11	PTFE O ring	5005-008 <input type="checkbox"/>
12	Perfluoroelastomer O ring	5005-384 <input type="checkbox"/>
13	Spindle	845/0200
14	Viton O ring	5005-336 <input type="checkbox"/>
15	Stuffing clamp flange	845/0016
16	M6 hex bolt (2)	5111-022
17	Stuffing seal	845/0061 <input type="checkbox"/>
18	Spindle bearing	845/0062 <input type="checkbox"/>
19	Perfluoroelastomer O ring	10133PHT <input type="checkbox"/>
20	Lifting fork	845/H010A
21	Handle	20607
22	Handle linkage assembly	324/8910/1

Seal Kit

Description	Part No.
All parts marked <input type="checkbox"/> in the Parts List	845/00SK



4" 90° Cleanflow Footvalve - Pneumatically Actuated

Part No: 875/4800SS



Specification

Nominal size/body angle

4" / 90°

Inlet connection

Flanged: 8 x 18mm holes on a 210mm PCD

Outlet connection

Flanged: 8 x 18mm holes on a 180mm PCD

Properties

With pneumatic actuator

Materials

Seating area: Superseat (alloy 625)

Contact parts: 316 stainless steel

Main seal: Fortyt

Alternatives are available, refer to the Design Options page

Design Conditions

Weight:	32.1 Kg
Design Pressure (MAWP):	4 Bar
Test Pressure:	6 Bar
Design Temperature min:	-40°C
Design Temperature max:	200°C

NOTE: The Design Conditions and Section View dimensions are for the specified part number only.

Approvals

BS EN14433

Range

Description	Part No.
Standard valve	875/4800SS
With replaceable seat inlet	875/4800SSRX
With replaceable seat inlet, conical poppet, steam chamber	875/4800SSHRX

Related Parts

Description	Part No.
Weld-in flange	854/9000
Stud kit (875/4800SS only)	875/2044
CNAF/PTFE inlet gasket	5005-467
CNAF/PTFE outlet gasket	5005-468
Mating flange - DIN100 PN16	875/4150
Bolting kit for mating flange 875/4150	875/4160
Valve operation decal	845/0320

Section View

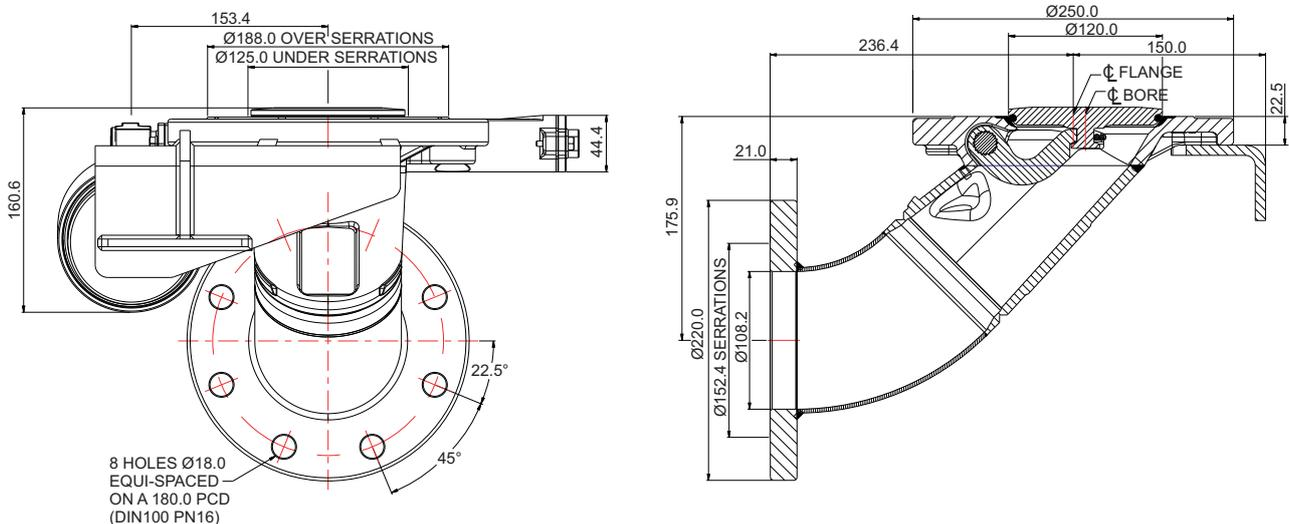



4" 90° Cleanflow Footvalve - Pneumatically Actuated

Part No: 875/4800SS

Parts Drawing

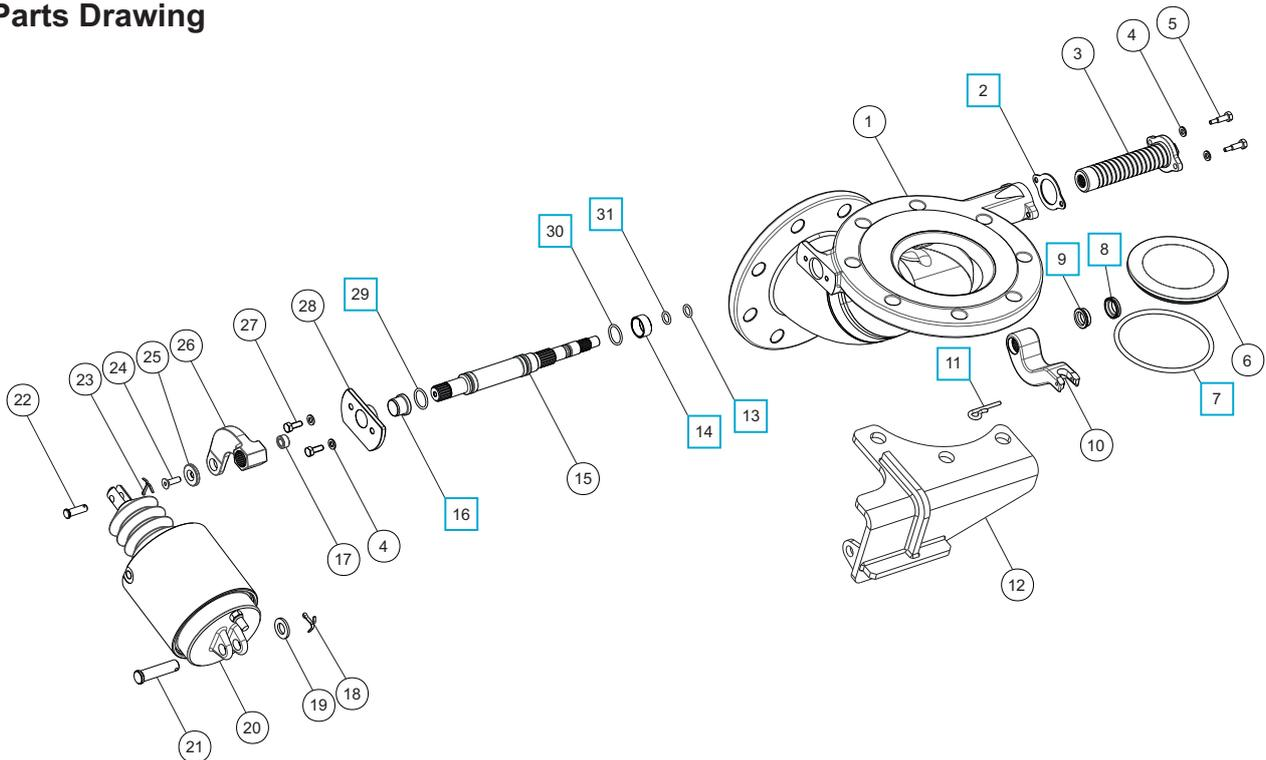

Parts List

Item	Description	Part No.
1	Body	875/4110B
2	Spring boss gasket	5005-846 <input type="checkbox"/>
3	Spring assembly	875/0050
4	Spring washer (4)	5113-008
5	Clamp screw (2)	845/0017
6	Poppet	875/0040
7	Fortyt O ring	5005-349 <input type="checkbox"/>
8	PTFE bottom bush seal	845/0064 <input type="checkbox"/>
9	Bottom seal energizer	845/0063 <input type="checkbox"/>
10	Lifting fork	875/0010
11	Retaining pin	845/0015 <input type="checkbox"/>
12	Pneumatic cylinder bracket	845/8064
13	Perfluoroelastomer O ring	10133PHT <input type="checkbox"/>
14	PTFE spindle bearing	845/0062 <input type="checkbox"/>
15	Main spindle	875/0200
16	PTFE spindle stuffing seal	845/0061 <input type="checkbox"/>
17	Bronze bush	844/2011
18	Split pin	5220-008
19	Plain washer	5113-006
20	Pneumatic cylinder	875/2125
21	Clevis pin	875/2122
22	Clevis pin	875/2121
23	Split pin	5118-016
24	Countersunk bolt	5111-019

Parts List

Item	Description	Part No.
25	Retaining washer	20370/2
26	Crank arm	844/2049
27	Hex bolt (2)	5111-022
28	Stuffing clamp flange	845/0066
29	Viton O ring	5005-336 <input type="checkbox"/>
30	Perfluoroelastomer O ring	5005-384 <input type="checkbox"/>
31	PTFE O ring	5005-008 <input type="checkbox"/>

Seal Kit

Description	Part No.
All parts marked <input type="checkbox"/> in the Parts List	875/00SK



6" 180° Cleanflow Footvalve - Hydraulically Actuated

Part No: 874/0000



Specification

Nominal size/body angle

6" / 150mm / 180°

Inlet connection

Flanged: 12 x 0.6" (14.0) holes equi-spaced on a 9.3" (234.95) PCD - 6" TTMA sump specification

Outlet connection

Flanged: 12 x 0.44" (11.1) holes equi-spaced on a 8.13" (206.4) PCD - 6" TTMA flange specification

Properties

Hydraulically actuated with 1/8" NPT connection

Materials

Contact parts: 316 stainless steel

Main seal: Fortyt

Design Conditions

Weight: 68.7 Lb (31.2 Kg)
 Design Pressure (MAWP): 58 PSI (4 Bar)
 Test Pressure: 100.1 PSI (6.9 Bar)
 Design Temperature Min: -4°F (-20°C)
 Design Temperature Max: 302°F (150°C)

Hydraulic Actuator MAWP: 1305.3 PSI (90 Bar)

Max. Internal Pressure on Opening: 20 PSI (1.38 B) Ambient
 Max. Internal Pressure on Opening: 15 PSI (1.03 B) At Temp.

NOTE: The Design Conditions and Section View dimensions are for the specified part number only.

Design Code

BS EN 14433

Related Parts

Description	Part No.
Sump weld-in flange - 1/2" UNC holes	874/0040
Sump weld in flange - M12 holes	874/0055
Stud kit - 1/2" UNC	874/00SK
Stud kit - M12	874/00MSK
CNAF/PTFE inlet gasket	874/0041
CNAF/PTFE outlet gasket	874/0042

Section View

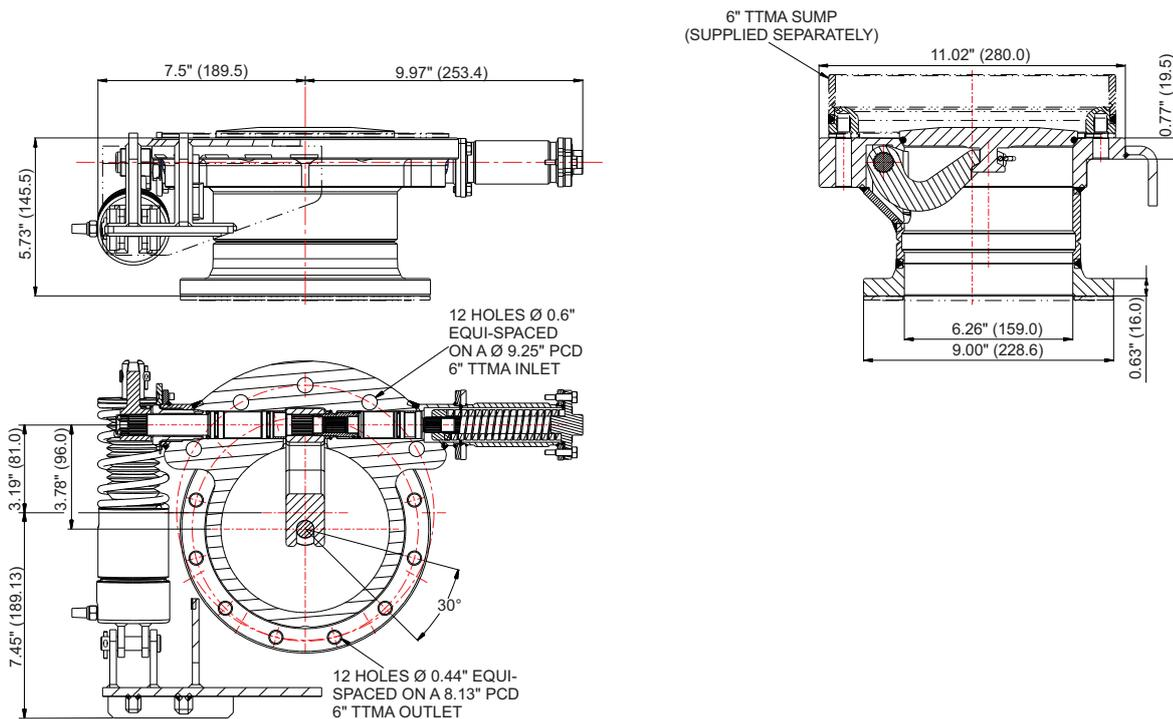



6" 180° Cleanflow Footvalve - Hydraulically Actuated

Part No: 874/0000

Parts Drawing

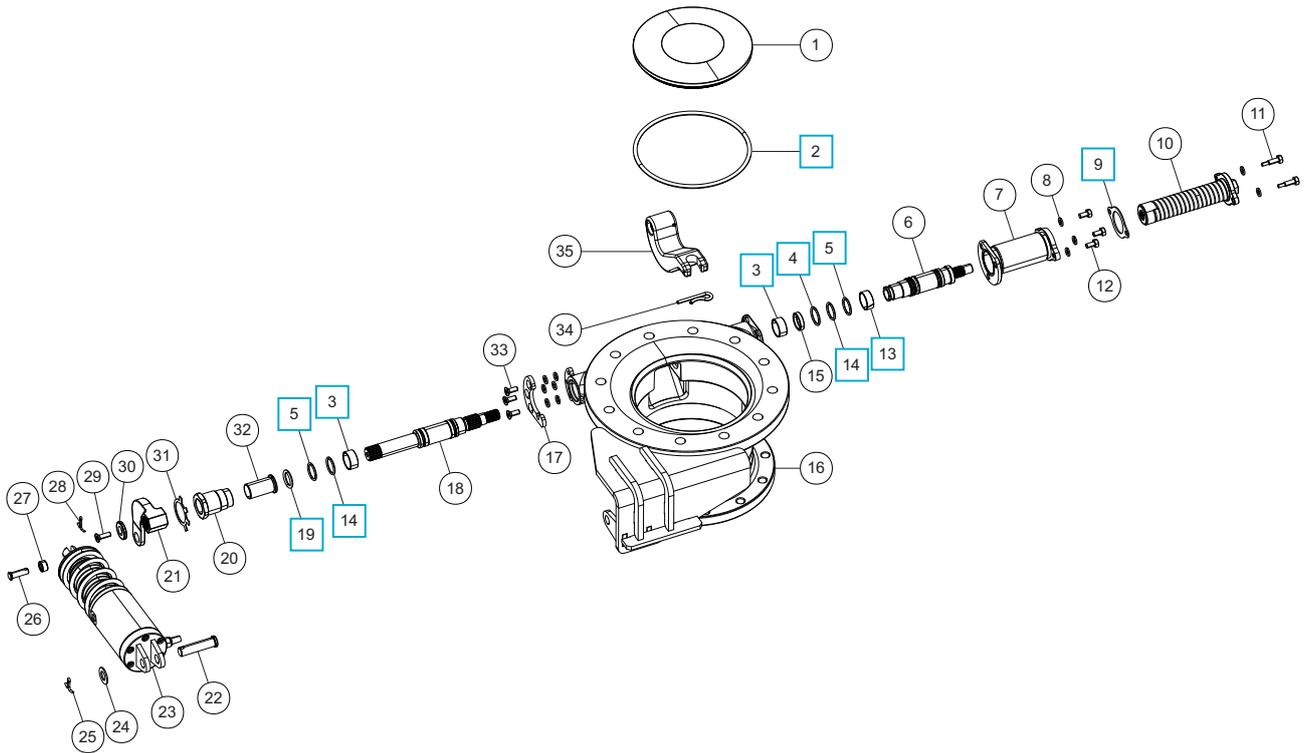

Parts List

Item	Description	Part No.
1	Poppet	874/0015
2	Fortyt O ring	ORB360FO <input type="checkbox"/>
3	Spindle bearing (2)	845/0062 <input type="checkbox"/>
4	PTFE O ring	5005-319 <input type="checkbox"/>
5	Viton O ring (2)	5005-336MF <input type="checkbox"/>
6	Bottom extension spindle	874/0025
7	Spring extension housing	874/0014
8	M6 spring washer (11)	5113-008
9	Spring housing gasket	5005-846 <input type="checkbox"/>
10	Torsion spring	875/0050
11	M6 hex screw (2)	845/0017
12	M6 hex bolt (3)	5111-050
13	Split bearing	874/0023 <input type="checkbox"/>
14	Perfluoroelastomer O ring (2)	5005-384 <input type="checkbox"/>
15	Bottom seal energizer	874/0027
16	Body	874/0100
17	Indicator plate	874/0019
18	Main spindle	874/0020
19	PTFE O ring	5005-113 <input type="checkbox"/>
20	Stuffing gland nut	874/0016
21	Extended crank arm	844/2067
22	Clevis pin	875/2122
23	Hydraulic cylinder *Note	875/2160N <input type="checkbox"/>
24	M12 plain washer	5113-006
25	1/8" split pin	5220-008

Parts List

Item	Description	Part No.
26	Clevis pin	844/2121
27	Bronze bush	844/2011
28	3/32" split pin	5118-016
29	6mm countersunk bolt	5111-019
30	Retaining washer	20370/2
31	Locking washer	853/7029
32	Spindle guide bush	874/0024
33	M6 countersunk bolt (3)	5111-030
34	Retaining pin	845/0015
35	Lifting fork	874/0018

Seal Kits

Description	Part No.
Seal kit for footvalve 874/0000: contains all parts marked <input type="checkbox"/> in the Parts List	874/0000SK
<input type="checkbox"/> Seal kit for hydraulic cylinder 875/2160N, includes silencer	875/2160NSK

NOTE: A hydraulic cylinder with BSP connections and a compatible seal kit is available. Please contact Fort Vale.



3" 30° Highlift Footvalve

Part No: 830/3000A



Specification

Nominal size/body angle

80mm / 30°

Inlet connection - dual drilled

8 x 14mm holes equi-spaced on a 177.8mm PCD & 4 x 18mm holes equi-spaced on a 177.8mm PCD

Outlet connection

Flanged: 4 x 17mm holes on a 160mm PCD

Materials

Seating area: Superseat (alloy 625)

Contact parts: 316 stainless steel

Main seal: Fortyt

Alternatives are available, refer to the Design Options page

Design Conditions

Weight:	8.4 Kg
Design Pressure (MAWP):	4 Bar
Test Pressure:	7.3 Bar
Design Temperature Min:	-40°C
Design Temperature Max:	200°C

NOTE: The Design Conditions and Section View dimensions are for the specified part number only.

Design Codes

BS EN 14433 (BS space EN space - no year date)

Related Parts

Description	Part No.
Weld-in flange - 8 hole	324/9000
Stud kit for 8 hole inlet	324/2070
CNAF/PTFE inlet gasket - 8 hole	5005-015
Weld-in flange - 4 hole	341/001L
Stud kit for 4 hole inlet	311/3700
CNAF/PTFE inlet gasket - 4 hole	5005-032
CNAF/PTFE ring gasket	5005-049
CNAF/PTFE square outlet gasket	5005-195
Valve operation decal	326/0300

Section View

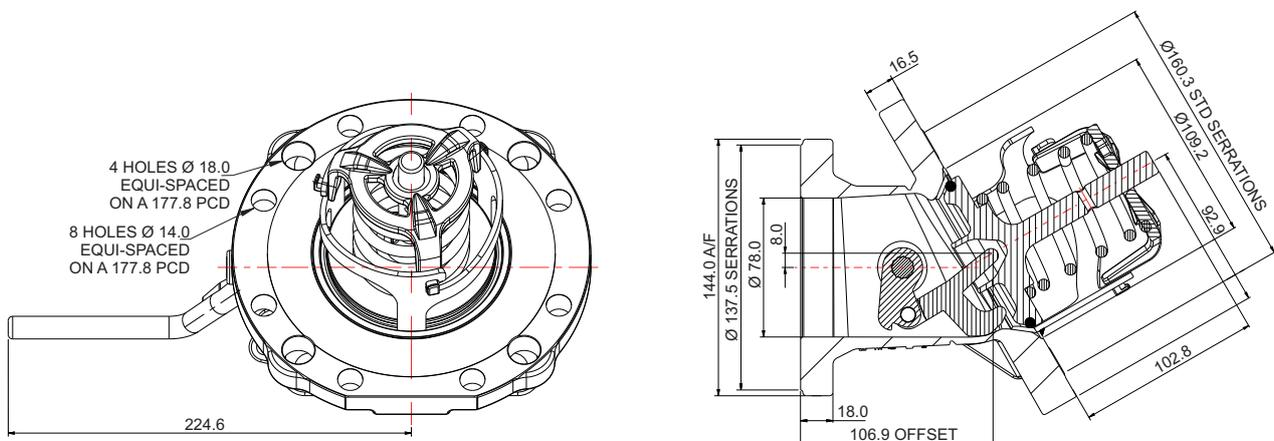



3" 30° Highlift Footvalve

Part No: 830/3000A

Parts Drawing

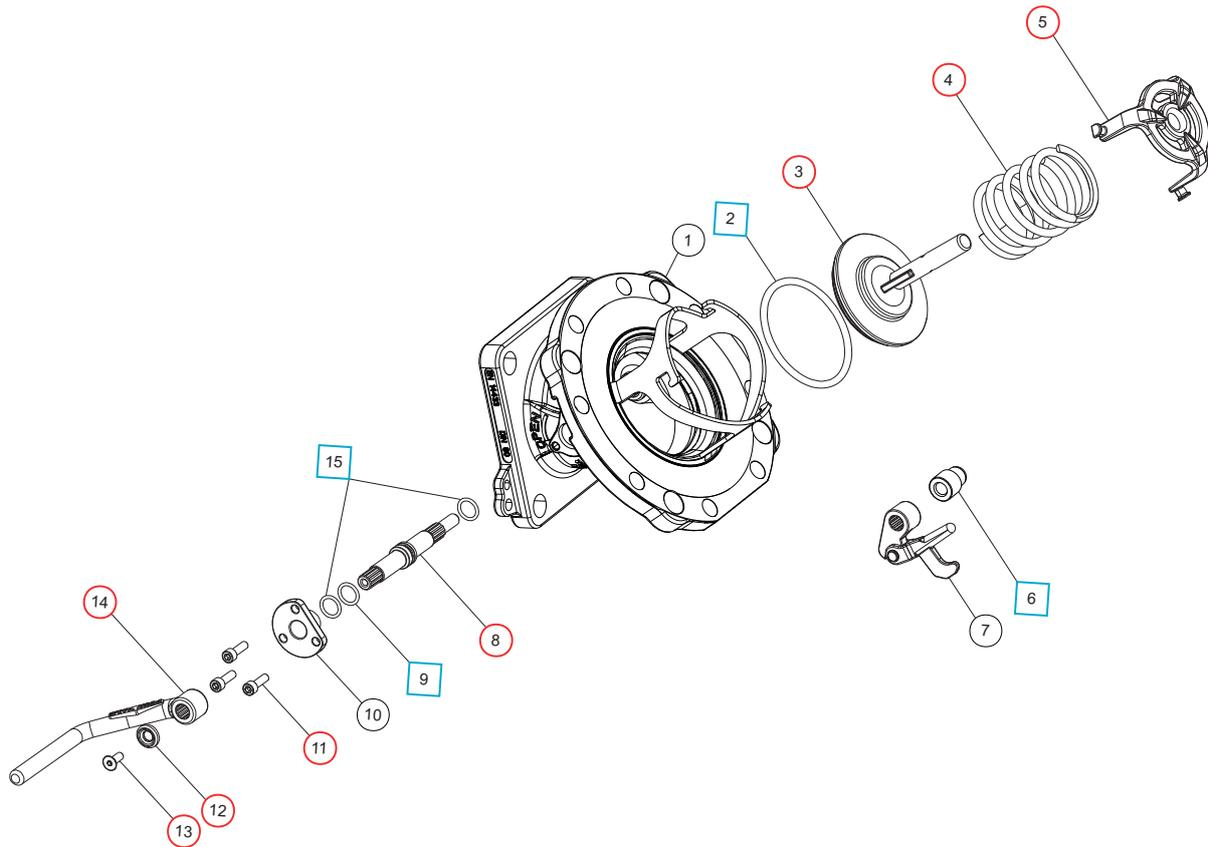

Parts List

Item	Description	Part No.	
1	Body	830/3100B	
2	Fortyt O ring	5005-104	□ ○
3	Solid poppet	324/2020	○
4	Spring	5104-971	○
5	Spring top plate	290/6104	○
6	PTFE crankshaft end bush	20362	□ ○
7	Crank block assembly	821/0300	
8	Spindle	821/0010	○
9	Viton O ring	20361	□ ○
10	Stuffing clamp	324/1004	
11	M6 x 20mm capscrew (3)	5111-017	○
12	Handle retaining washer	20370	○
13	Handle retaining screw	5111-030	○
14	Handle	330/5010	○
15	PTFE O ring	20363	□ ○

Seal Kit

Description	Part No.
All parts marked □ in the Parts List	826/00SK

Repair Kit

Description	Part No.
All parts marked ○ in the Parts List	826/00RKA

Spare Part Kit

Description	Part No.
Spindle & crank block assembly Includes item 6, 7, 8, 9 & 15	821/0200



3" 45° MKIII Highlift Footvalve

Part No: 826/1200A



Specification

Nominal size/body angle

80mm / 45°

Inlet connection

Flanged: 8 x 14mm holes equi-spaced on a 178mm PCD

Outlet connection

Flanged: 4 x 17mm holes on a 160mm PCD

Materials

Seating area: Superseat (alloy 625)

Contact parts: 316 stainless steel

Main seal: Fortyt

Alternatives are available, refer to the Design Options page

Design Conditions

Weight:	8.9 Kg
Design Pressure (MAWP):	4 Bar
Test Pressure:	6 Bar
Design Temperature Min:	-40°C
Design Temperature Max:	200°C

NOTE: The Design Conditions and Section View dimensions are for the specified part number only.

Approvals

BS EN14433

Design Approval by Lloyds Register of Shipping

Range

Description	Part No.
Standard specification	826/1200A
With alloy C276 seating area	826/1200AHS

Related Parts

Description	Part No.
Weld-in flange	324/9000
Stud kit	324/2070
Bolting kit - 4 hole outlet	311/3500
CNAF/PTFE inlet gasket	5005-015
CNAF/PTFE outlet gasket	5005-049
Valve operation decal	326/0300

Section View

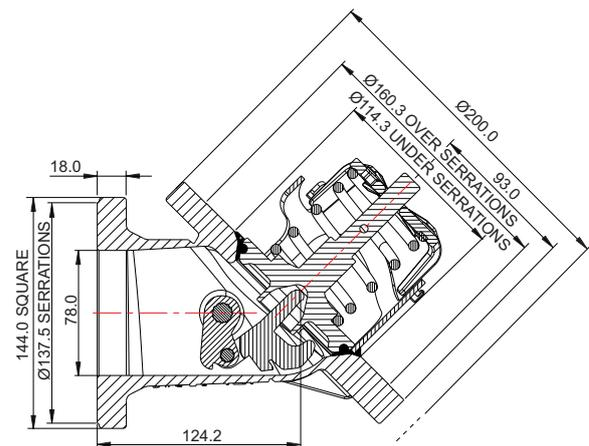
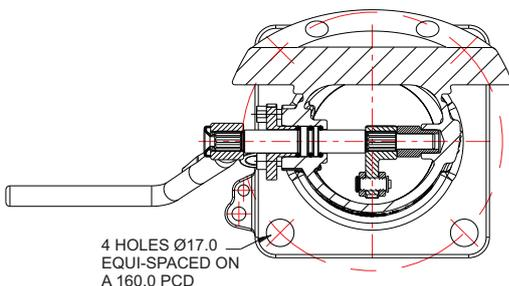
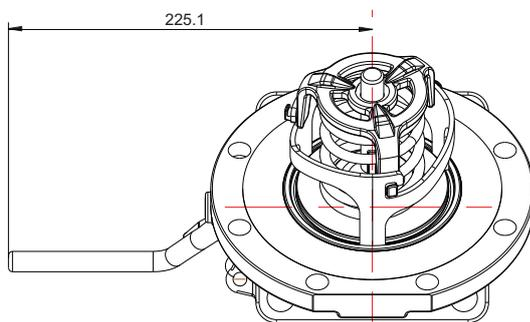



3" 45° MKIII Highlift Footvalve

Part No: 826/1200A

Parts Drawing

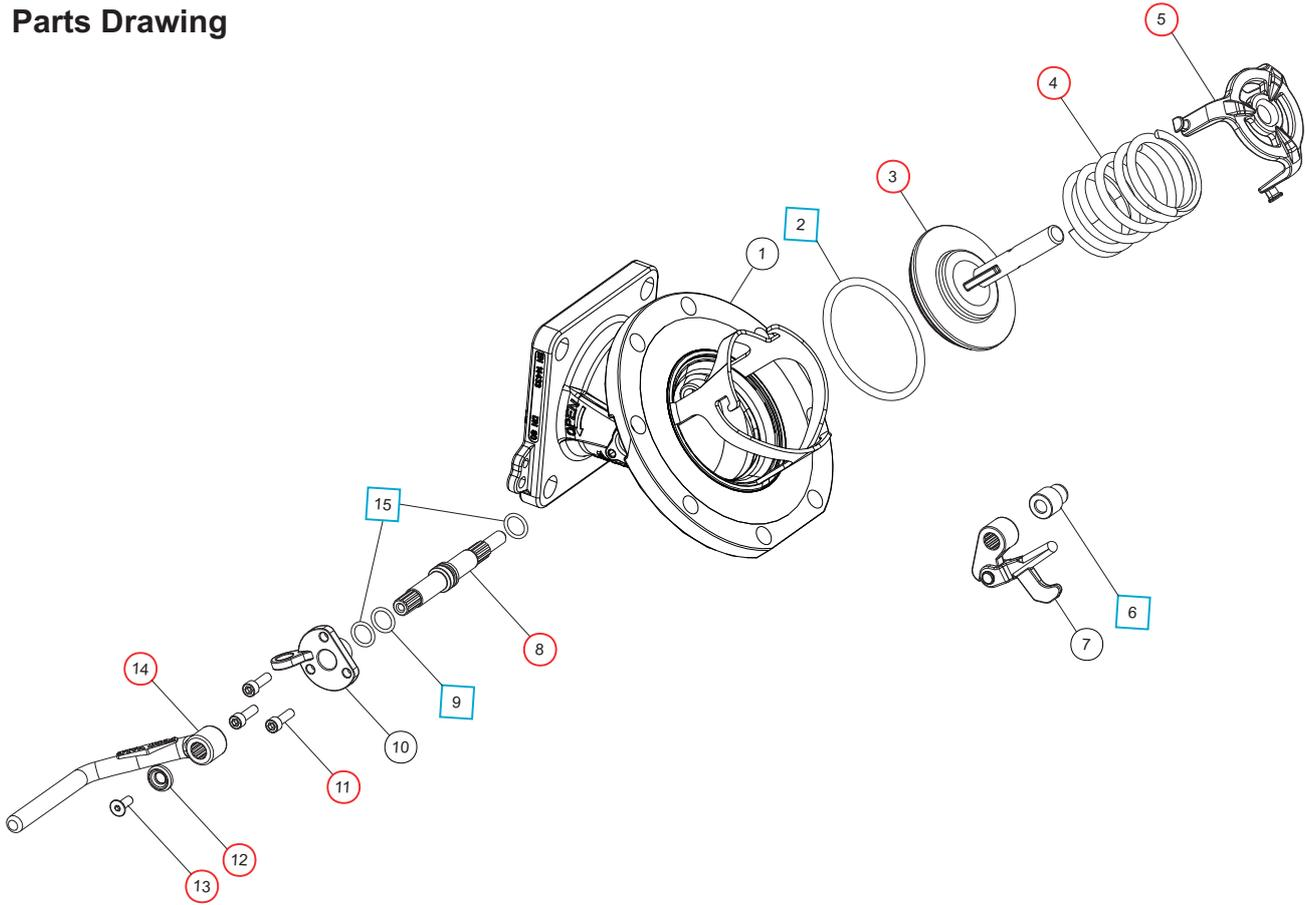

Parts List

Item	Description	Part No.
1	Body	826/1100B
2	Fortyt O ring	5005-104 <input type="checkbox"/> <input type="radio"/>
3	Solid poppet	324/2020 <input type="radio"/>
4	Spring	5104-971 <input type="radio"/>
5	Spring top plate	290/6104 <input type="radio"/>
6	PTFE crankshaft end bush	20362 <input type="checkbox"/> <input type="radio"/>
7	Crank block assembly	821/0300
8	Spindle	821/0010 <input type="radio"/>
9	Viton O ring	20361 <input type="checkbox"/> <input type="radio"/>
10	Stuffing clamp	324/1001
11	M6 capscrew (3)	5111-017 <input type="radio"/>
12	Handle retaining washer	20370 <input type="radio"/>
13	Handle retaining screw	5111-030 <input type="radio"/>
14	Handle	330/5010 <input type="radio"/>
15	PTFE O ring (2)	20363 <input type="checkbox"/> <input type="radio"/>

Seal Kit

Description	Part No.
All parts marked <input type="checkbox"/> in the Parts List	826/00SK

Repair Kit

Description	Part No.
All parts marked <input type="radio"/> in the Parts List	826/00RKA

Spare Parts

Description	Type	Part No.
Spindle & crank block assy Item 6, 7, 8, 9, & 15		821/0200



3" 90° Tankstream Footvalve

Part No: 28F/0000F



Specification

Nominal size/body angle

3" / 90°

Inlet connection

Flanged: 12 x 14mm holes on a 158.8mm PCD (6 inlet holes are plugged with a plastic plug)

Outlet connection

Flanged: 8 x 10.5mm holes on a 124mm PCD

Materials

Contact parts: 316 stainless steel

Main seal: Fortyt

Alternatives are available, refer to the Design Options page

Design Conditions

Weight:	7.5 Kg
Design Pressure (MAWP):	4 Bar
Test Pressure:	6 Bar
Design Temperature min:	-20°C
Design Temperature max:	200°C

NOTE: The Design Conditions and Section View dimensions are for the specified part number only.

Range

Description	Part No.
Standard valve, Fortyt seal	28F/0000F
Standard valve, Viton seal	28F/0000V

Related Parts

Description	Part No.
Weld-in flange	11954/S
Stud kit	290/1300
CNAF/PTFE inlet gasket	5005-016
CNAF/PTFE outlet gasket	5005-445
3" TTMA mating flange	299/7116

Section View

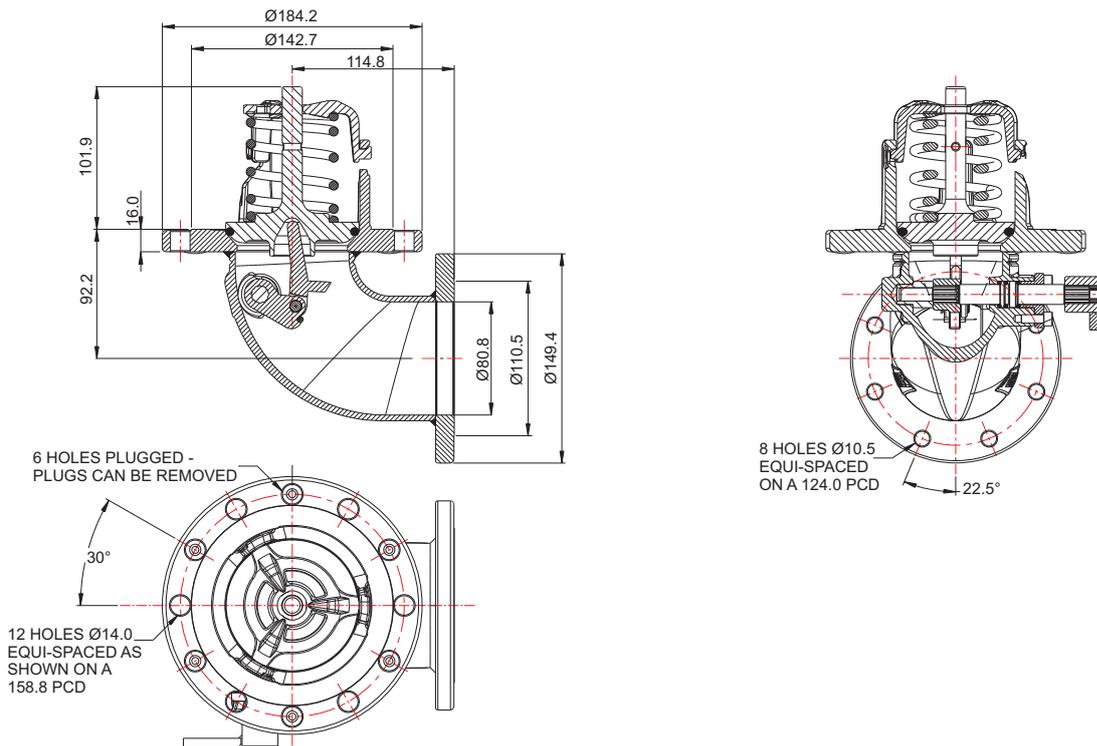



3" 90° Tankstream Footvalve

Part No: 28F/0000F

Parts Drawing

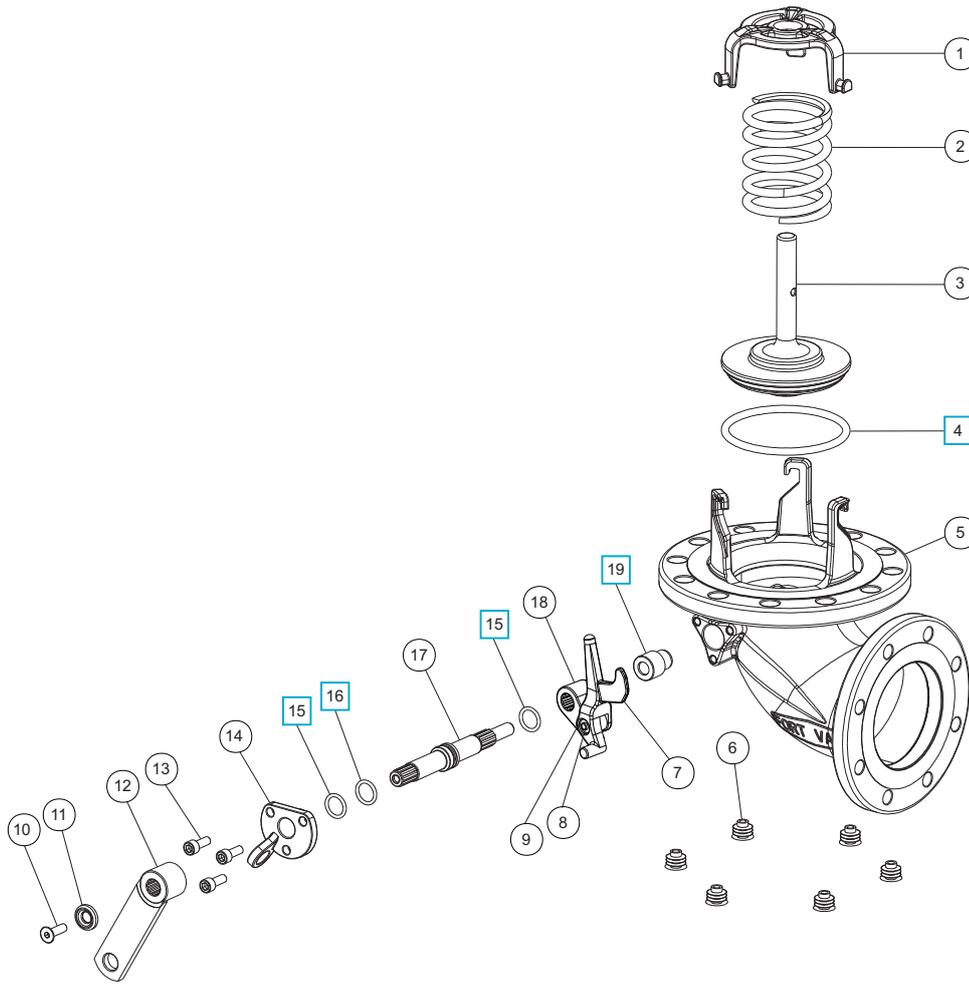

Parts List

Item	Description	Part No.	
1	Spring top plate	290/6104	
2	Closure spring	5104-971	
3	Solid poppet	324/2020	
4	Fortyt O ring	5005-104	☐
5	Body assembly	28F/0003	
6	Plastic plug (6)	5028-227	
7	Lifting finger	821/0056	
8	Pivot pin	821/0034	
9	Plain washer	5113-015	
10	Countersunk bolt	5111-019	
11	Retaining washer	20370	
12	Crank arm	20607	
13	Cap screw (3)	5111-017	
14	Stuffing clamp	324/1001	
15	PTFE O ring (2)	20363	☐
16	Viton O ring	20361	☐
17	Spindle	821/0010	
18	Crank block	821/0025	
19	Crankshaft end bush	20362	☐

Seal Kit

Description	Part No.
All parts marked ☐ in the Parts List	826/00SK



4" 45° Highlift Footvalve - Hydraulically Actuated

Part No: 854/0170GS

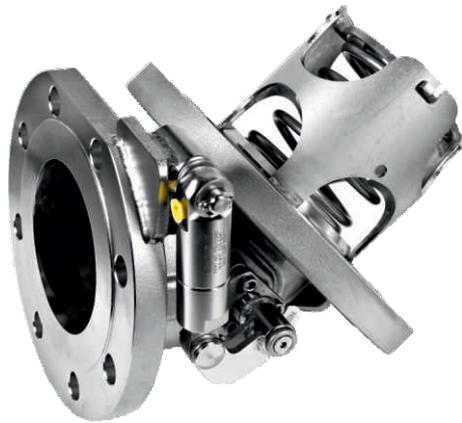

Specification

Nominal size/body angle

100mm / 45°

Inlet connection

Flanged: 8 x 18mm holes equi-spaced on a 210mm PCD

Outlet connection

Flanged: 8 x 18mm holes on a 180mm PCD

Properties

Hydraulic actuator with a 1/8" BSP connection

Materials

Seating area: Superseat (alloy 625)

Contact parts: 316 stainless steel

Main seal: Fortyt

Alternatives are available, refer to the Design Options page

Design Conditions: Footvalve

Weight:	18.7 Kg
Design Pressure (MAWP):	4 Bar
Test Pressure:	6 Bar
Design Temperature Min:	-40°C
Design Temperature Max:	205°C

NOTE: The Design Conditions and Section View dimensions are for the specified part number only.

Design Code

BS EN 14433

Design Conditions: Hydraulic Cylinder

Design Pressure (MAWP):	200 Bar
Test Pressure:	300 Bar
Design Temperature Min:	-40°C
Design Temperature Max:	100°C

Range

Description	Part No.
Standard valve	854/0170GS
Outlet flange with flat top & bottom	854/0170GS/1
Standard valve with steam heating	854/0170GSS

Related Parts

Description	Part No.
Weld-in flange	854/9000
CNAF/PTFE inlet gasket	5005-467
Glass filled PTFE outlet gasket	5005-437/1P1

Section View

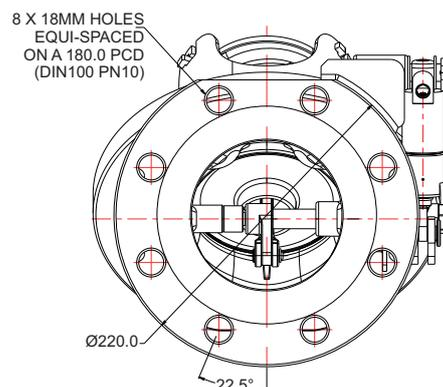
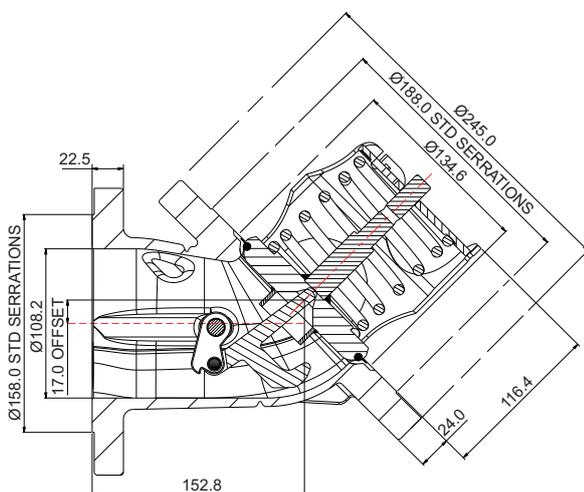



4" 45° Highlift Footvalve - Hydraulically Actuated

Part No: 854/0170GS

Parts Drawing

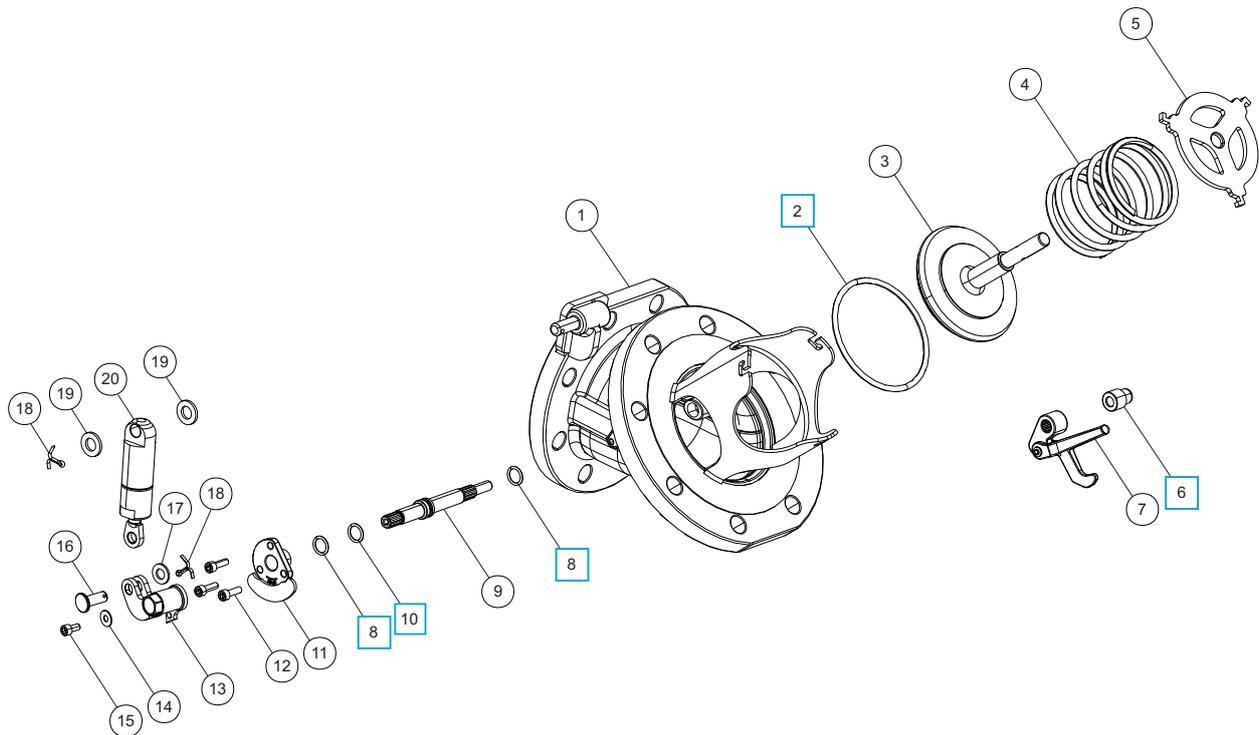

Parts List

Item	Description	Part No.
1	Body	854/0175B
2	Fortyt O ring	5005-349 <input type="checkbox"/>
3	Poppet	853/2010
4	Spring	5104-973-2
5	Bayonet	854/2026
6	Crankshaft end bush	20362 <input type="checkbox"/>
7	Crank block & lifting finger	854/0300
8	PTFE O ring (2)	20363 <input type="checkbox"/>
9	Spindle	853/0010
10	Viton O ring	20361 <input type="checkbox"/>
11	Stuffing plate	854/0136
12	M6 cap screw (3)	5111-017
13	Crank arm	178/0261
14	Retaining washer	5113-039
15	M6 cap screw	5111-034
16	Cross pin	178/0259
17	M10 plain washer	5113-009
18	Split pin (2)	5220-008
19	M12 plain washer (2)	5113-006
20	Hydraulic cylinder	178/0260

Seal Kit

Description	Part No.
All parts marked <input type="checkbox"/> in the Parts List	854/00SK



3" 45° Uniflow Bottom Discharge Assembly

Part No: 806/4000

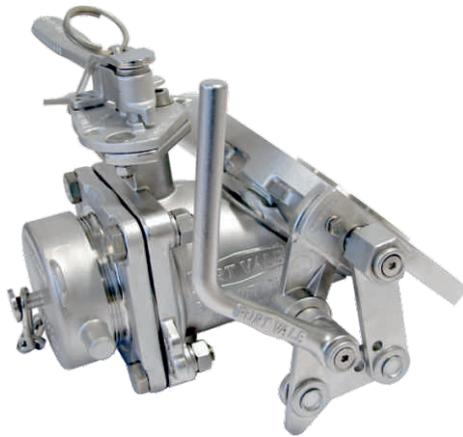

Specification

Nominal size/body angle

80mm / 45°

Inlet connection

Flanged: 8 x 14mm holes equi-spaced on a 178mm PCD

Outlet connection

3" BSP spigot flange with cap

Properties

Cleanflow footvalve with integral butterfly valve

Materials

Seating area: Superseat (alloy 625)

Contact parts: 316 stainless steel

Footvalve main seal: Fortyt

Butterfly valve main seal: PTFE

Cap seal: PTFE

Alternatives are available, refer to the Design Options page

Design Conditions

Weight:	13.0 Kg
Design Pressure (MAWP):	4 Bar
Test Pressure:	6 Bar
Design Temperature Min:	-40°C
Design Temperature Max:	200°C

NOTE: The Design Conditions and Section View dimensions are for the specified part number only.

Approvals

BS EN14432

BS EN14433

Design Approval by Lloyds Register of Shipping

Range

Description	Part No.
Standard specification: 80mm / 45°	806/4000
With alloy C276 seating area	806/4000HS
Standard specification: 80mm / 30°	807/4000

Related Parts

Description	Part No.
Weld-in flange	324/9000
Stud kit	845/2040
CNAF/PTFE inlet gasket	5005-015
Valve operation decal	326/0303

Section View

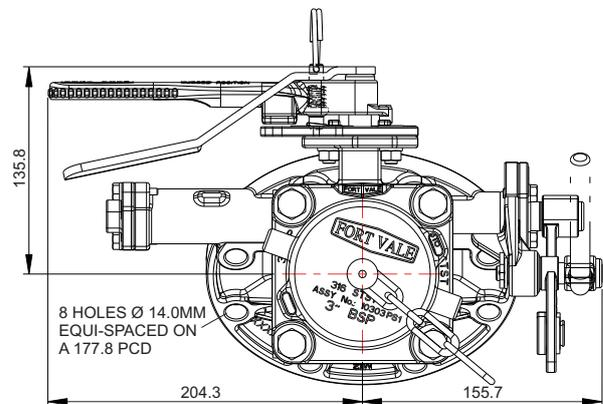
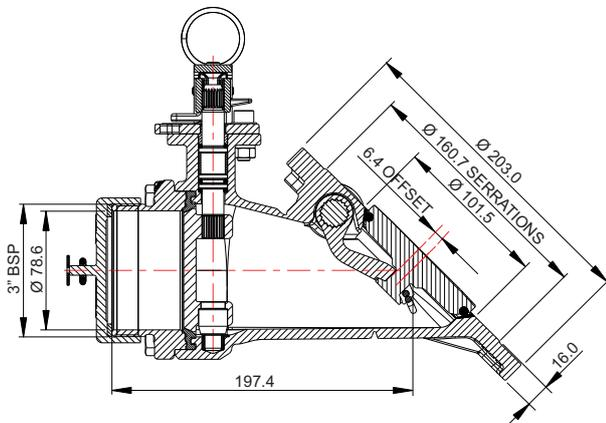



3" 45° Uniflow Bottom Discharge Assembly

Part No: 806/4000

Parts Drawing

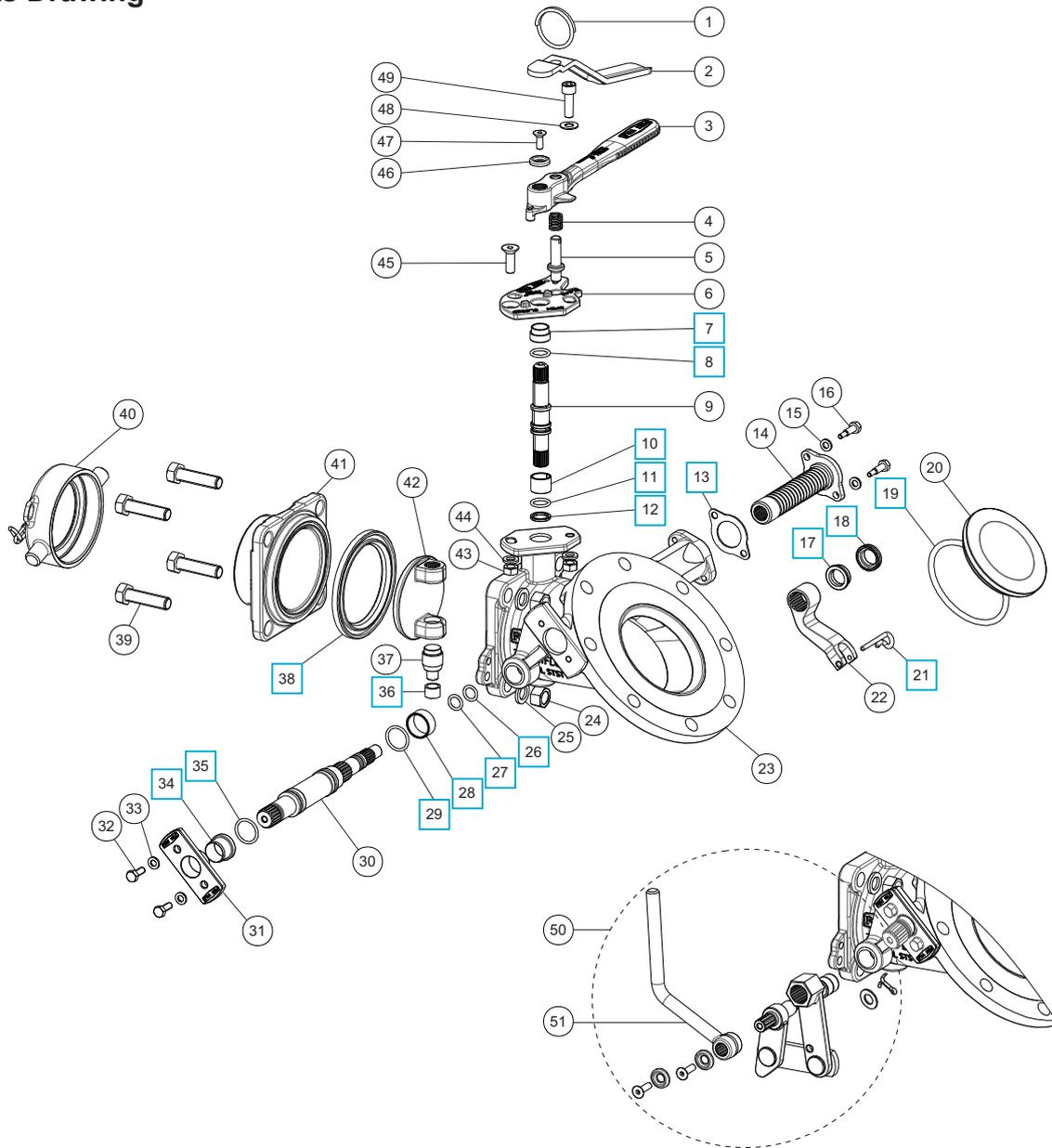



3" 45° Uniflow Bottom Discharge Assembly

Part No: 806/4000

Parts List

Item	Description	Part No.	
1	Split ring	368/0011	
2	Handle lever	368/9837	
3	Butterfly valve handle	368/0057	
4	Handle location spring	368/0012	
5	Handle location pin	368/0010	
6	Stuffing clamp	368/0047	
7	Stuffing clamp bush	368/0301	<input type="checkbox"/>
8	PTFE O ring	20363	<input type="checkbox"/>
9	Spindle	368/0201	
10	Split bearing	252/0517	<input type="checkbox"/>
11	Viton O ring	20361	<input type="checkbox"/>
12	PTFE spindle seat	368/0009	<input type="checkbox"/>
13	Spring boss gasket	5005-845	<input type="checkbox"/>
14	Spring assembly	845/0050	
15	Spring washer (2)	5113-008	
16	Clamp screw (2)	845/0017	
17	Seal energizer	845/0063	<input type="checkbox"/>
18	Bush seal	845/0064	<input type="checkbox"/>
19	Fortyt O ring	5005-104	<input type="checkbox"/>
20	Poppet	845/0040	
21	Retaining pin	845/0015	<input type="checkbox"/>
22	Lifting fork	845/0010	
23	Body	845/1107B	
24	M12 full nut (4)	5112-006	
25	M12 spring washer (4)	5113-010	
26	Perfluoroelastomer O ring	10133PHT	<input type="checkbox"/>
27	PTFE O ring	5005-008	<input type="checkbox"/>
28	Spindle bearing	845/0062	<input type="checkbox"/>
29	Perlast O ring	5005-384	<input type="checkbox"/>
30	Spindle	845/0200	
31	Stuffing clamp	845/0016	
32	Clamp bolt (2)	5111-022	
33	Spring washer (2)	5113-008	
34	Stuffing seal	845/0061	<input type="checkbox"/>
35	Viton O ring	5005-336	<input type="checkbox"/>
36	PTFE bottom bush	368/0035	<input type="checkbox"/>
37	Bottom spindle	368/0036	
38	PTFE butterfly valve main seal	368/0002	<input type="checkbox"/>
39	M12 hex bolt (4)	5111-023	
40	3" BSP cap with chain & seal	10303PS1	
41	Outlet flange	368/5129	
42	Closure plate	368/0400	
43	M8 full nut (2)	5112-001	
44	M8 spring washer (2)	5113-003	
45	M8 countersunk bolt	5111-085	
46	Retaining washer	20370	
47	M6 set screw	5111-030	

Parts List

Item	Description	Part No.
48	M8 plain washer	5113-005
49	M8 cap screw	5111-148
50	Handle linkage assembly	324/8910
51	Handle *Refer to Handle Options Table	

Footvalve Handle Options

Specification	Type	Part No.
Std. Cleanflow handle		324/8670
Cranked Cleanflow handle		324/8671
Std. Highlift handle		330/5010

Seal Kit

Description	Part No.
All parts marked <input type="checkbox"/> in the Parts List	806/40SK



3" 45° Univalve Bottom Discharge Assembly

Part No: 804/4000A



Specification

Nominal size/body angle
80mm / 45°

Inlet connection

Flanged: 8 x 14mm holes equi-spaced on a 178mm PCD

Outlet connection

3" BSP spigot flange with cap

Properties

Highlift footvalve with integral butterfly valve

Materials

Seating area: Superseat (alloy 625)

Contact parts: 316 stainless steel

Footvalve main seal: Fortyt

Butterfly valve main seal: PTFE

Cap seal: PTFE

Alternatives are available, refer to the Design Options page

Design Conditions

Weight:	12.5 Kg
Design Pressure (MAWP):	4 Bar
Test Pressure:	6 Bar
Design Temperature Min:	-55°C
Design Temperature Max:	200°C

NOTE: The Design Conditions and Section View dimensions are for the specified part number only.

Approvals

BS EN14432

BS EN14433

Design Approval by Lloyds Register of Shipping

Range

Description	Part No.
Standard specification	804/4000A
With alloy C276 seating area	804/4000AHS
Superseat; 3" camlock outlet & cap	804/4020A

Related Parts

Description	Part No.
Weld-in flange	324/9000
Stud kit	324/2070
CNAF/PTFE inlet gasket	5005-015
Valve operation decal	326/0302

Section View

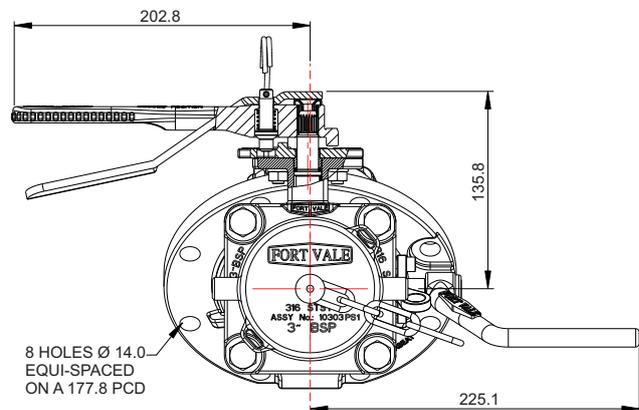
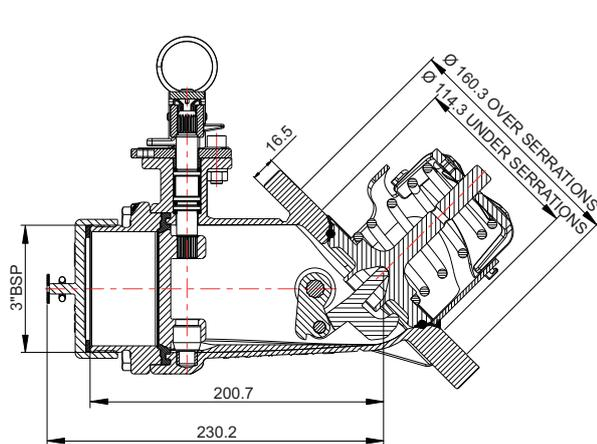



3" 45° Univalve Bottom Discharge Assembly

Part No: 804/4000A

Parts Drawing

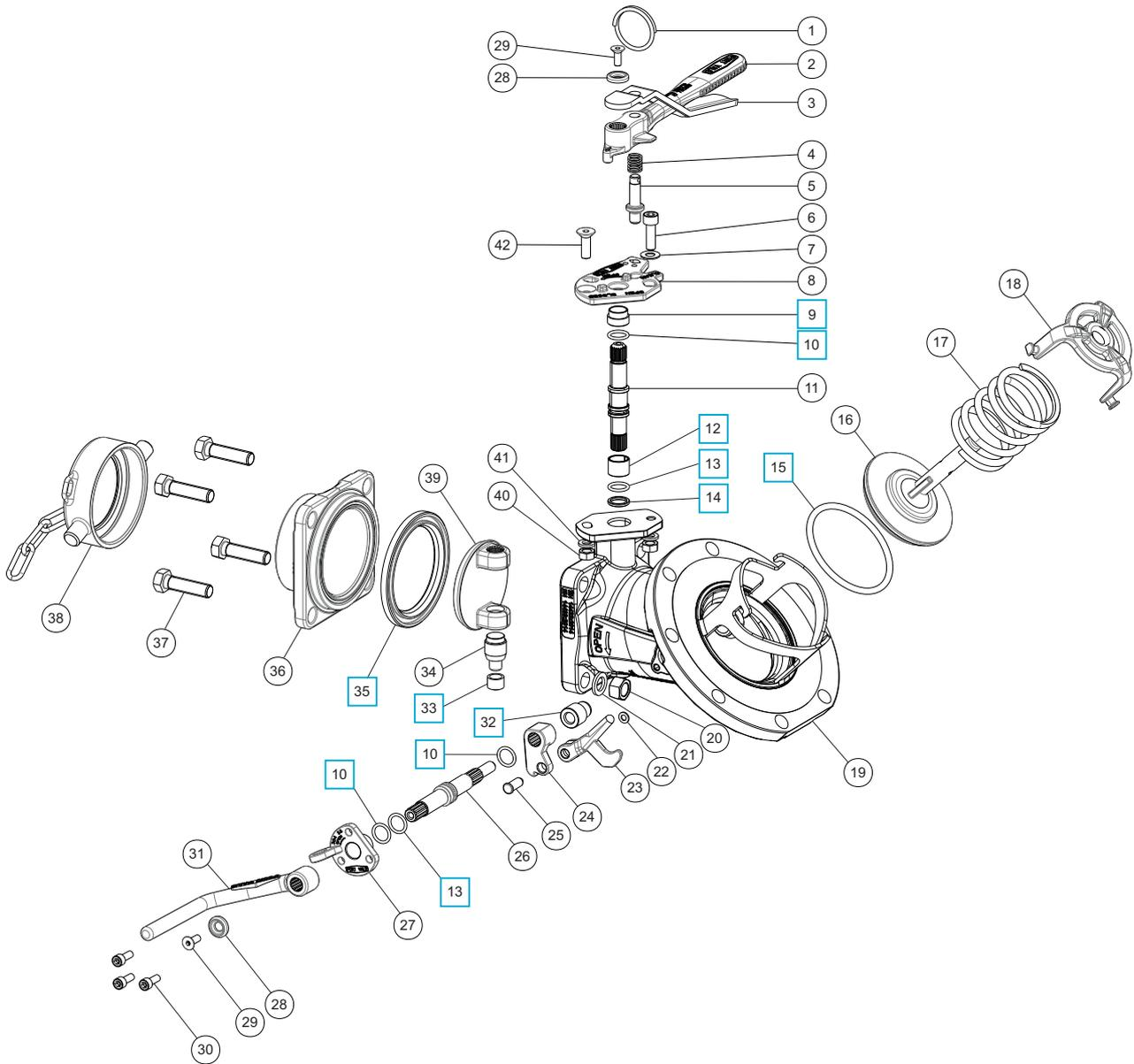



3" 45° Univalve Bottom Discharge Assembly

Part No: 804/4000A

Parts List

Item	Description	Part No.	
1	Split ring	368/0011	
2	Butterfly valve handle	368/0057	
3	Handle lever	368/9837	
4	Handle location spring	368/0012	
5	Handle location pin	368/0010	
6	M8 cap screw	5111-148	
7	M8 plain washer	5113-005	
8	Stuffing clamp	368/0047	
9	Stuffing clamp bush	368/0301	<input type="checkbox"/>
10	PTFE O ring (3)	20363	<input type="checkbox"/>
11	Spindle	368/0201	
12	Split bearing	252/0517	<input type="checkbox"/>
13	Viton O ring (2)	20361	<input type="checkbox"/>
14	PTFE spindle seat	368/0009	<input type="checkbox"/>
15	Fortyt O ring	5005-104	<input type="checkbox"/>
16	Poppet	324/2020	
17	Closure spring	5104-971	
18	Spring top plate	290/6104	
19	Body assembly	826/1252B	
20	M12 full nut (4)	5112-006	
21	M12 spring washer (4)	5113-010	
22	5mm plain washer	5113-015	
23	Lifting finger	821/0033	
24	Crank block	821/0025	
25	Pivot pin	821/0034	
26	Spindle	821/0010	
27	Stuffing clamp	324/1001	
28	Retaining washer (2)	20370	
29	M6 bolt (2)	5111-030	
30	M6 cap screw (3)	5111-017	
31	Footvalve handle	330/5010	
32	PTFE crankshaft end bush	20362	<input type="checkbox"/>
33	PTFE bottom bush	368/0035	<input type="checkbox"/>
34	Bottom spindle	368/0036	
35	PTFE butterfly valve main seal	368/0002	<input type="checkbox"/>
36	Outlet flange	368/5129	
37	M12 hex bolt (4)	5111-023	
38	3" BSP cap with chain & seal	10303PS1	
39	Closure plate	368/0400	
40	M8 full nut (2)	5112-001	
41	M8 spring washer (2)	5113-003	
42	M8 countersunk bolt	5111-085	

Seal Kit

Description	Part No.
All parts marked <input type="checkbox"/> in the Parts List	804/40SK



Footvalve Replaceable Seat Kit - Cleanflow Footvalve

Accessories & Spare Parts



Specification

The Cleanflow footvalve replaceable seat kit lets you replace the footvalve seating area if there is damage or corrosion. This saves time and avoids the cost of replacing a complete valve.

We also supply a complete 3" 45° Cleanflow footvalve assembly with replaceable seat, please refer to Range.

Compatibility

3"/80mm Cleanflow footvalve: 30°, 45°, 90°, 180°
 4"/100mm Cleanflow footvalve: 30°, 45°, 90°, 180°

Seating flange materials

316 stainless steel
 904L stainless steel
 High nickel alloy
 Titanium

IMPORTANT: A Cleanflow footvalve with a replaceable seat protrudes more from the tank and the outlet centre line is lower than that of a standard valve. Please contact us for dimensions and more information.

Range

Description	Part No.
3" Cleanflow replaceable seat kit	845/16CKX *
4" Cleanflow replaceable seat kit	875/16CKX *
3" 45° Cleanflow with replaceable seat	845/16RXX *

* The seating flange material changes the Part No.

Kit Parts Drawing

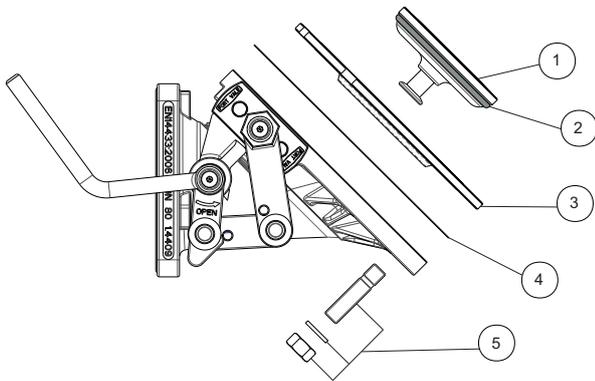

Kit Parts List

Item	Description	3" Kit Part No.	4" Kit Part No.
1	Extended poppet	845/0042	875/0042
2	Fortyt O ring	5005-104	5005-349
3	Seating flange *Note	845/0090X	875/0090S
4	PTFE gasket	5005-829	5005-855
5	Stud kit	845/2055	875/2055

NOTE: The seating flange material changes the Part No.



Footvalve Replaceable Seat Kit - Highlift Footvalve

Accessories & Spare Parts



Specification

The 3" 45° Highlift footvalve assembly with replaceable seat lets you replace the footvalve seating flange assembly if there is damage or corrosion. This saves time and avoids the cost of replacing a complete valve.

Please refer to the Spare Parts Drawing and List.

Seating flange materials

316 stainless steel
High nickel alloy
Titanium

Range

Description	Part No.
3" 45° Highlift with replaceable seat	826/0800XA *

* The seating flange material changes the Part No.

Spare Parts Drawing

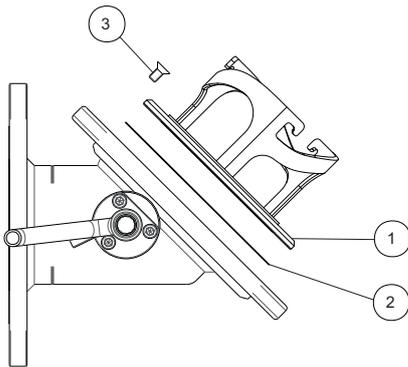

Spare Parts List

Item	Description	Part No.
1	Seating flange *Note	826/0817X
2	PTFE gasket	5005-828
3	Retaining screw (3)	5111-018

NOTE: The seating flange material changes the Part No.

IMPORTANT: Some of the spare parts for a replaceable seat Highlift footvalve are different from a standard Highlift footvalve. Please contact Fort Vale for footvalve spare parts.



Valve Repair and Maintenance Accessories & Spare Parts



We supply a range of special tools and repair kits to do scheduled maintenance and repair procedures to our valves.

We recommend that you use the correct special tools to help you do maintenance and repairs quickly and easily without causing damage to the valve or the new spare parts.

A selection of step-by-step maintenance instruction manuals is also available, please contact us.

CAUTION: Valve maintenance and repair can be dangerous. To do maintenance, you must have experience and qualifications related to valve installation on pressure vessels and systems.

Relief Valve Pressure/Vacuum Test Rig Part No: 400/8000



Specification

You can use the relief valve test rig to test the pressure and vacuum setting of Hyper Maxi, Super Maxi, Twinact, Uniact, Minnow and Steam relief valves.

Valve connection

2½" BSP.

We supply adaptors to change to other BSP and flanged connections.

Test rig supply connection

¼" BSP female socket

Test range

From -0.7 Bar to 6.9 Bar (-10 PSI to 100 PSI)

Related documents

Operating Instructions: OPIN26. Please contact us.

Footvalve & Relief Valve Seat Repair Kit Part No: 3" Kit - 400/2600 Part No: 4" Kit - 400/2900



Specification

You can use the seat repair kit to re-surface the seating face of a valve if there is damage caused by corrosion.

Compatible

3" Kit: compatible with 2½" Super Maxi relief valve and 3" Cleanflow and Highlift footvalves

4" Kit: compatible with 4" Cleanflow & Highlift footvalves

Connection

Compatible with power tools with a ½" chuck

Kit contents

Selection of grinding and polishing discs

Selection of face-forming tools

Instruction manual

Related documents

Operating Instructions: 3" Kit OPIN70, 4" Kit OPIN77.

Please contact us.

Spare Parts: Grinding Discs

Description	Part No. 3"	Part No. 4"
Box of 100 x 60 grit	400/2610	400/2615
Box of 100 x 80 grit	400/2620	400/2625
Box of 100 x 180 grit	400/2630	400/2635
Box of 100 x 500 grit	400/2640	400/2645



Valve Repair and Maintenance Accessories & Spare Parts



Relief Valve Tool Kits

Description	Part No.
Test rig adaptor flange - adapts 2½" BSP to 3" ASA150, DIN65 PN10 & DIN80 PN6	425/1000
C spanner - to install/remove Twinact relief valves	400/3000
C spanner - to install/remove Super Maxi relief valves	400/3001
Tightening tool for MKIII Super Maxi relief valves	400/8380
Tool kit - 1½" & 2½" Twinact valves	400/1000
Tool kit - 65mm & 80mm Super Maxi & Hyper Maxi relief valves	400/8300



Footvalve Tool Kits

Description	Part No.
3" Cleanflow footvalve tool kit	400/2150
3" Highlift footvalve tool kit	400/2450



Ball Valve Tool Kits

Description	Part No.
1½" ball valve tool kit	400/2500
3" ball valve tool kit	400/2200

Butterfly Valve Tool Kits

Description	Part No.
2" butterfly valve tool kit	400/2300
3" butterfly valve tool kit	400/2700



APPENDIX

Catalogue

A	Bolt Torque Guide & Step Loading Procedure
B	Client Responsibilities - Valves & Accessories



Bolt Torque Guide & Step Loading Procedure

Installation & Operating Instructions

Flange Bolting

CAUTION: Weld-distortion and too much tightening force will cause damage to a flange.

It is important not to cause damage to weld-in flanges and mating flanges. If a flange is damaged it will not give a satisfactory seal when a gasket and secondary mating flange is installed.

Bolt-stress can decrease after initial tightening. The cause can be deformation of the gasket material, particularly with soft materials such as a CNAF/PTFE envelope gasket.

Best procedure recommends that, after initial bolting, the flange joint is tightened again after a period of time. Most gasket manufacturers advise a period of 24 hours. ASME PCC-1-2000 GUIDELINES FOR PRESSURE BOUNDARY BOLTED FLANGE JOINT ASSEMBLY advises a minimum period of 4 hours.

Bolt torque calculations are based on a flat flange to within 0.15mm.

Recommended bolt torque values will be reduced if a lubrication is used.

Bolt Torque

Bolt Torque Values

Fort Vale bolt torque values are given as a reference guide only and are based on:

- The use of a CNAF/PTFE gasket.
- Unlubricated fasteners.
- A flange flat to within 0.15mm.

CAUTION: If you use a different gasket material, a lubricant, a flange with distortion, you must re-calculate the torque value.

Bolt Torque Procedure

To install flanged parts correctly:

- Examine the mating flange of the part.
- If the flange is marked with a torque value, obey that torque value.
- If there is no torque value marked on the mating flange, obey the bolt torque values given in Table BT1.
- Tighten the bolts evenly in sequence. See Figure BT1.
- Obey the Step Loading Procedure (ASME PCC-1-2000). See next page.

Table BT1

Thread	Torque Value
M10	30 Nm (22 lbf.ft)
M12	65 Nm (48 lbf.ft)
M16	81 Nm (60 lbf.ft)

Figure BT1

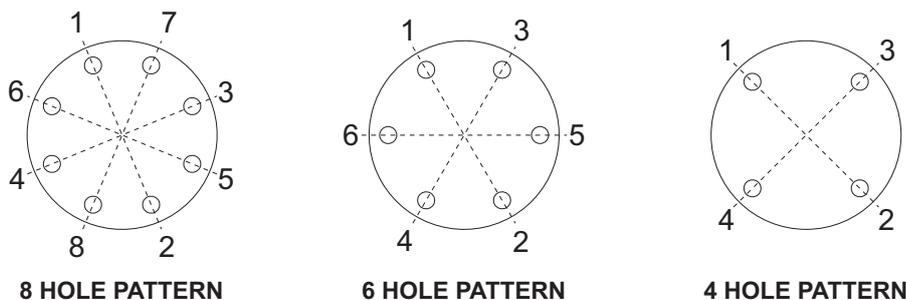



Bolt Torque Guide & Step Loading Procedure

Installation & Operating Instructions

Step Loading Procedure

To install flanged parts correctly, obey the Step Loading Procedure extract from ASME PCC-1-2000:

Install

Hand tighten, then “snug up” to 15 Nm (10 lbf.ft) to 30 Nm (20 lbf.ft) (not to exceed 20% of Target Torque). Check flange gap around circumference for uniformity. If the gap around the circumference is not reasonably uniform, make the appropriate adjustments by selective tightening before proceeding.

Round 1

Tighten to 20% to 30% of Target Torque. Check flange gap around circumference for uniformity. If the gap around the circumference is not reasonably uniform, make the appropriate adjustments by selective tightening before proceeding.

Round 2

Tighten to 50% to 70% of Target Torque. Check flange gap around circumference for uniformity. If the gap around the circumference is not reasonably uniform, make the appropriate adjustments by selective tightening before proceeding.

Round 3

Tighten to 100% of Target Torque. Check flange gap around circumference for uniformity. If the gap around the circumference is not reasonably uniform, make the appropriate adjustments by selective tightening before proceeding.

Round 4

Continue tightening the bolts, but on a rotational clockwise pattern until no further nut rotation occurs at the Round 3 Target Torque value. For indicator bolting, tighten bolts until the indicator rod retraction readings for all bolts are within the specified range.

Round 5

Time permitting, wait a minimum of 4 hr and repeat Round 4; this will restore the short-term creep relaxation/embedment losses. If the flange is subjected to a subsequent test pressure higher than its rating, it may be desirable to repeat this round after the test is completed.



Client Responsibilities - Valves & Accessories

Installation, Operation & Maintenance Instructions

Compatibility

Make sure that the function and technical specification of the valve/accessory is compatible with the vessel service conditions and the cargo. This includes, but is not limited to:

- dimensions
- pressure/vacuum setting
- air/gas/liquid flow capacity
- maximum allowable working pressure
- test pressure
- minimum/maximum design temperatures
- materials of construction.

Maintenance

Fort Vale valves and accessories have a long life if you use them correctly in compatible service conditions. It is not necessary to lubricate the parts, but we recommend that you obey the precautions that follow:

Visual checks at regular intervals:

1. Examine the valve to make sure there is no damage, wear or corrosion.
2. Examine the valve and adjacent area to make sure there is no leakage of cargo.
3. Examine the fasteners to make sure they are not loose.
4. Make sure the valve operates correctly.

CAUTION: If you operate the valve with very corrosive cargo, or near its temperature and/or pressure limit (very high or very low temperature and/or pressure), do the visual checks more frequently.

As well as the visual checks, schedule suitable maintenance intervals for the valve based on how frequently the valve is used, the type of cargo and the service conditions.

After 2½ years of service, do the checks that follow:

1. Examine the valve to make sure there is no damage, wear or corrosion.
2. Make sure the valve operates correctly.
3. Do a pressure test on the valve.

After 5 years of service, do the checks that follow:

1. Disassemble and clean the valve.
2. Replace all the valve seals.

Replacement Parts

Do not adapt or change the valve. If you install a replacement part, it must be a genuine Fort Vale part.

WARNING: If you install a part that is not a genuine Fort Vale part, there is a risk of:

- injury to personnel
- permanent damage to the valve
- permanent damage to the vessel
- valve malfunction.

External Fire

If the valve is installed in an area where there is a risk of external fire, you must install compatible accessories to prevent damage to the valve.

Compatibility of Accessories

Accessory components must cause no interference with the valve function. Accessories must be made from compatible materials that will cause no damage to the valve materials. Do not install an accessory that will cause an increased load on the valve, i.e. mechanical, static, dynamic, thermal.

Mis-use

Obey the instructions and recommended procedures in the installation and operating instructions. Obey the pressure and temperature markings on the valve and on the drawing. Use the valve/accessory for its correct function only. Fort Vale accept no liability or responsibility for incorrect use of the valve/accessory.



Our subsidiaries are located in:

US Office

126 N. Virginia
La Porte
TX 77571
USA

Tel: +1 281 471 8100

Fax: +1 281 471 8116

Email: ussales@fortvale.com

Head Office

Calder Vale Park
Simonstone Lane
Simonstone, Burnley
Lancashire, BB12 7ND, UK

Tel: +44 (0) 1282 687120

Fax: +44 (0) 1282 687110

Email: sales@fortvale.com

China Office

Fort Vale Engineering Shanghai Ltd
Building 11 88 Yuanshan Road
Xinzhuang Industry Park
Shanghai 201108 China

Tel: +86 21 6442 1367

Fax: +86 21 6442 1376

Email: cnsales@fortvale.com

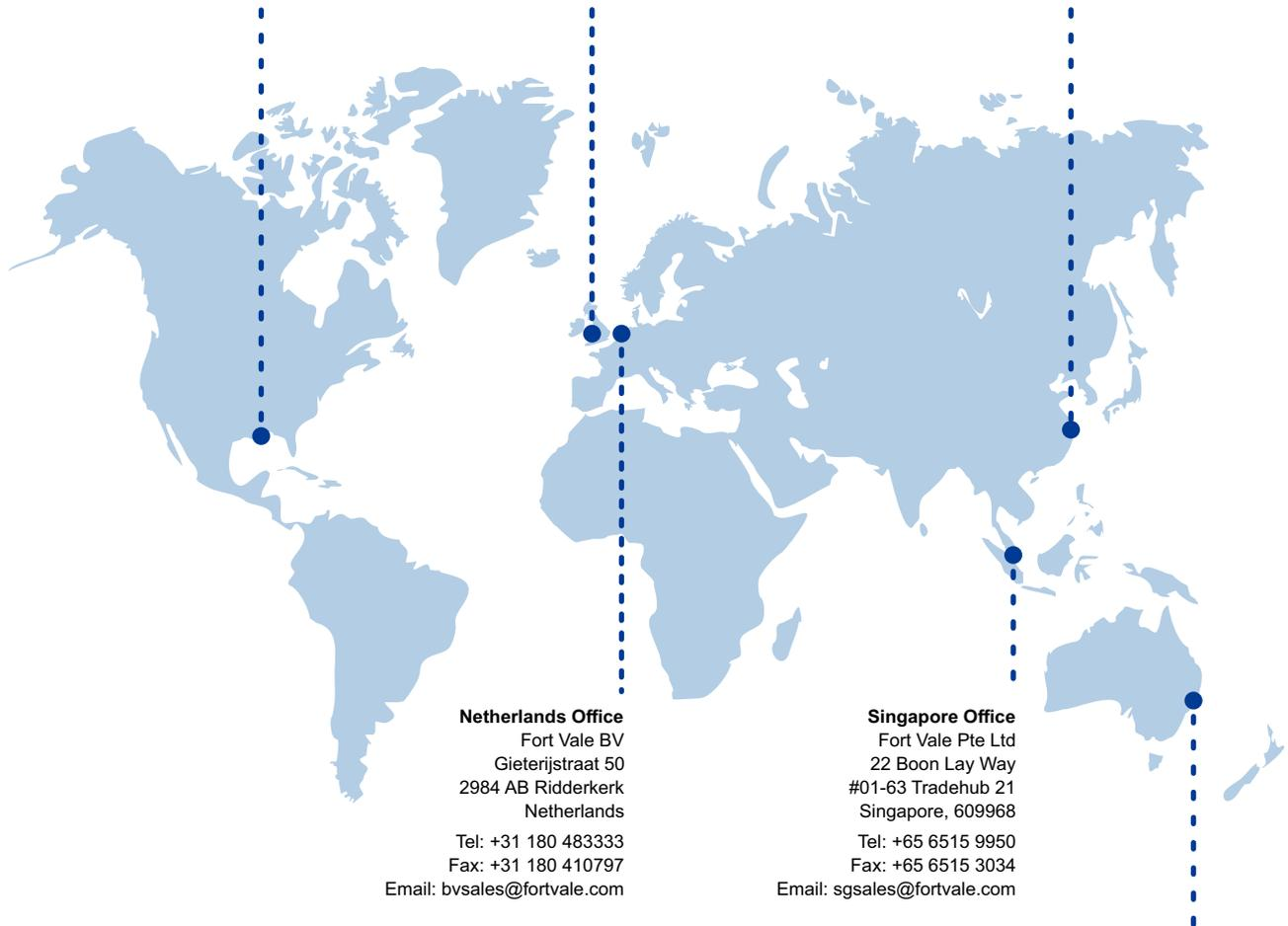

Netherlands Office

Fort Vale BV
Gieterijstraat 50
2984 AB Ridderkerk
Netherlands

Tel: +31 180 483333

Fax: +31 180 410797

Email: bvsales@fortvale.com

Singapore Office

Fort Vale Pte Ltd
22 Boon Lay Way
#01-63 Tradehub 21
Singapore, 609968

Tel: +65 6515 9950

Fax: +65 6515 3034

Email: sgsales@fortvale.com

Australia Office

Fort Vale Australia Pty Ltd
Bellwood Business Park
Unit 14, 49 Bellwood Street
Darra, Queensland, 4076

Tel: +61 7 3189 5059

Email: ausales@fortvale.com

We also have Authorised Distributors around the world to provide you with product sales and after-market services. To find your nearest distributor, please visit our website - www.fortvale.com

