



Catalogue

Standard Range of Fire Safe & Lethal Service Ball Valves



CONTENTS

Fire Safe & Lethal Service Ball Valves

Catalogue

Fire Safe & Lethal Service Ball Valves

1" Fire Safe / Lethal Service Ball Valve	3
2" Fire Safe / Lethal Service Ball Valve	5
2" Fire Safe Only Ball Valve	7
3" Fire Safe / Lethal Service Ball Valve	9

Appendix

Bolt Torque Guide & Step Loading Procedure	13
Client Responsibilities	15
Fort Vale Worldwide	17



1" Fire Safe / Lethal Service Ball Valve

Part No: 310/5000XXX

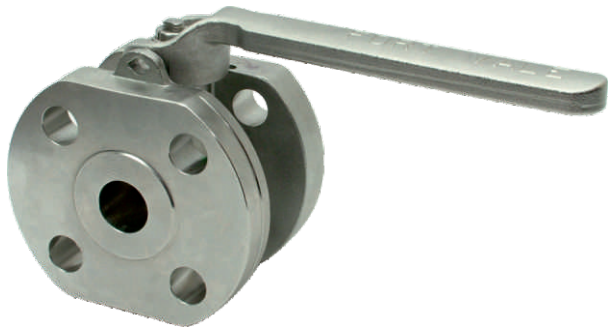

Specification

Nominal size

25mm

Tank connection

Flanged: 4 x 18mm holes on a 89mm PCD

Outlet/Process connection

Flanged: 4 x 18mm holes on a 89mm PCD

Options

Fire safe specification or lethal service specification - refer to Design Conditions: NOTE

Left or right hand operation

Materials

Contact parts: 316 stainless steel

Main seal: TFM PTFE

Design Conditions

Weight:	4.77 Kg
Design Pressure (MAWP):	16 Bar
Test Pressure:	24 Bar
Design Temperature Min:	-40°C
Design Temperature Max:	205°C

NOTE: The fire safe specification ball valve is not compatible with lethal service conditions. The lethal service specification ball valve is compatible with fire safe and lethal service conditions

Design Codes

BS EN14432, EN12516-2, EN10497
API 607

Range

Description	Part No.
1" fire safe valve, left hand	310/5000FSL
1" fire safe valve, right hand	310/5000FSR
1" fire safe/lethal service valve, left hand	310/5000LSL
1" fire safe/lethal service valve, right hand	310/5000LSR

Section View

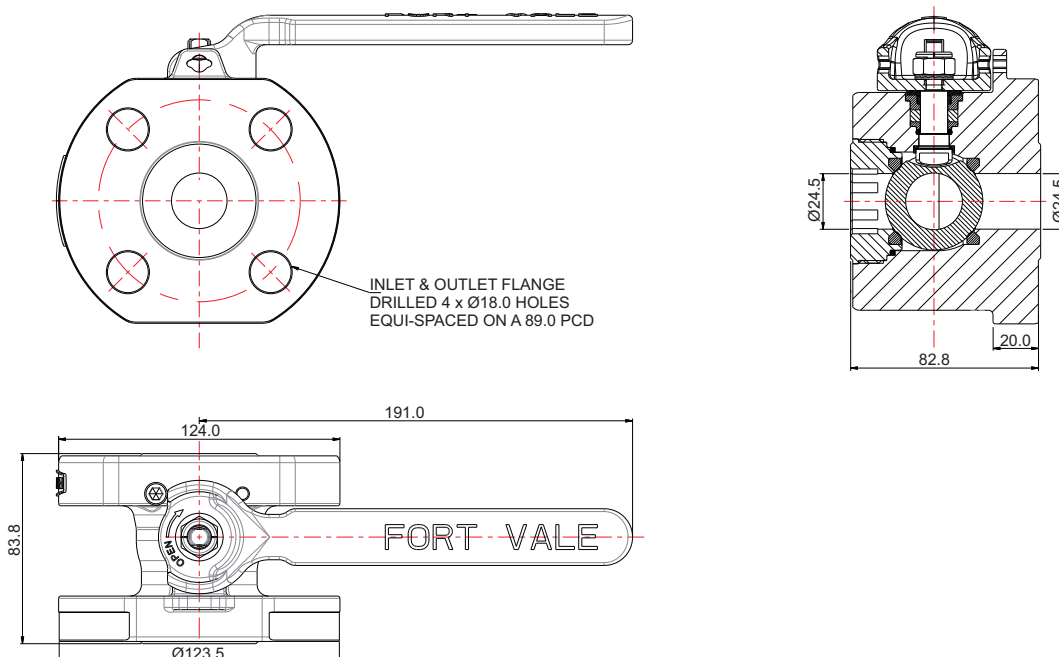



1" Fire Safe / Lethal Service Ball Valve

Part No: 310/5000XXX

Parts Drawing

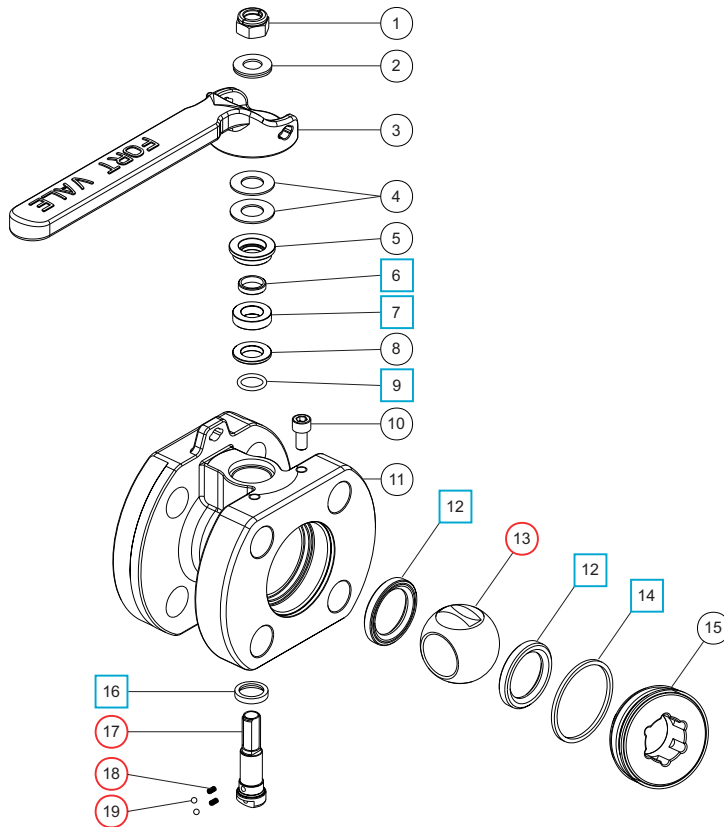

Parts List

Item	Description	Part No.
1	M10 locking nut *Note	5112-008-XX
2	M10 locking washer (pair)	5113-191
3	Handle *Note	310/0125XX
4	12mm Belleville washer (2)	5113-045
5	Stuffing gland	310/3458
6	Bearing bush	310/3443 □ ○
7	Gland seal	310/0133 □ ○
8	Stuffing gland	310/0130
9	Perfluoroelastomer O ring	5005-212PER □ ○
10	M6 cap screw	5111-034
11	1" ball valve body *Note	310/5010XX
12	TFM PTFE ball seat (2)	310/0102FS □ ○
13	Ball *Note	370/1002XX ○
14	Body seal	310/0106GR □ ○
15	Seal retainer	310/0176/2
16	Bottom bearing	310/0104FS □ ○
17	Spindle	310/0120FS ○
18	Plunger spring (2)	370-3469 ○
19	3mm ball (2)	10154SS ○

Seal Kit - All parts marked □ in the Parts List

Description	Part No.
For fire safe & lethal service valves	310/50LSK

Repair Kit - All parts marked ○ in the Parts List

Description	Part No.
For fire safe valves only	310/50FRK
For lethal service valves only	310/50LRK

NOTE: The valve specification changes the part number



2" Fire Safe / Lethal Service Ball Valve

Part No: 370/5000LSX

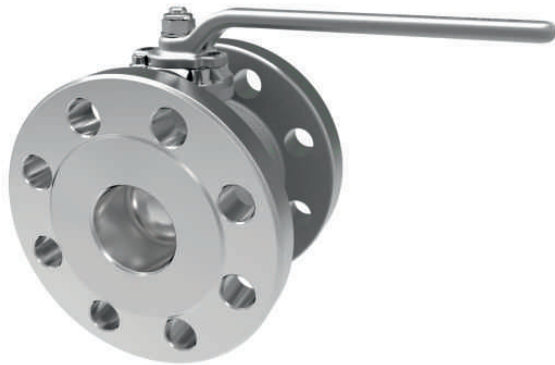

Specification

Nominal size

50mm

Tank connection

Flanged: 8 x 19mm holes on a 127mm PCD

Outlet/Process connection

Flanged: 8 x 19mm holes on a 127mm PCD

Properties

Refer to Design Conditions: NOTE

Options

Left or right hand operation

Materials

Contact parts: 316 stainless steel

Main seal: TFM PTFE

Design Conditions

Weight:	10.3 Kg
Design Pressure (MAWP):	16 Bar
Test Pressure:	24 Bar
Design Temperature Min:	-40°C
Design Temperature Max:	205°C

NOTE: This lethal service specification ball valve is compatible with fire safe and lethal service conditions.

Design Codes

BS EN14432, EN12516-2, EN10497
API 607

Range

Description	Part No.
2" fire safe/lethal service valve, left hand	370/5000LSL
2" fire safe/lethal service valve, right hand	370/5000LSR

Related Parts

Description	Part No.
Stainless steel/graphite spiral wound gasket: 2" ball valve inlet and outlet	5005-724SP

Section View

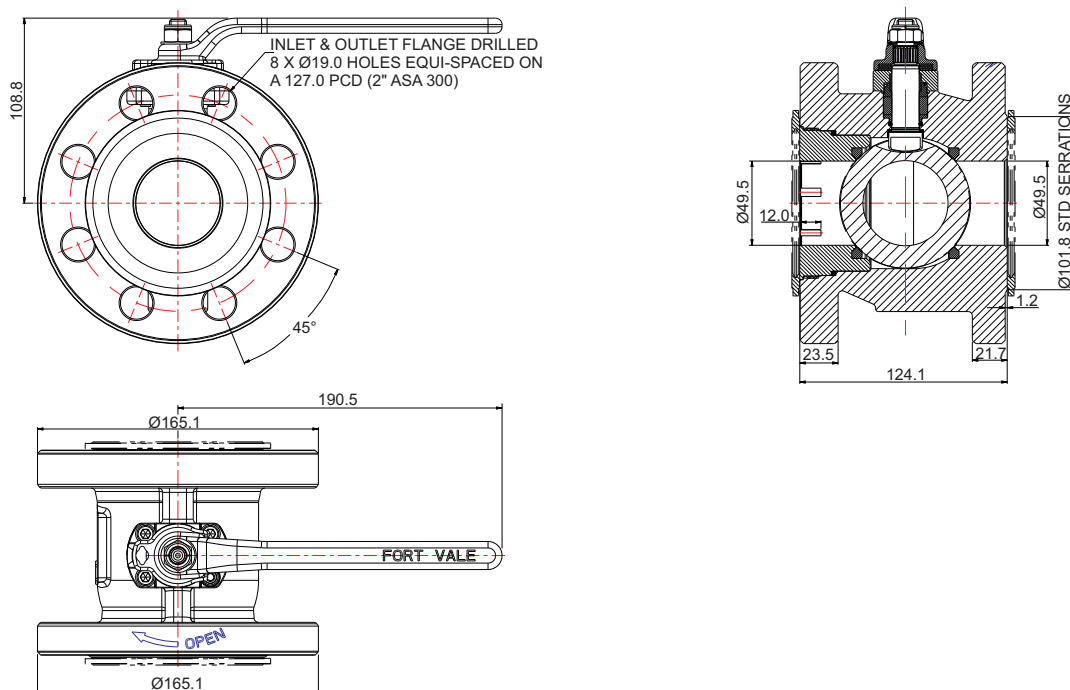



2" Fire Safe / Lethal Service Ball Valve

Part No: 370/5000LSX

Parts Drawing

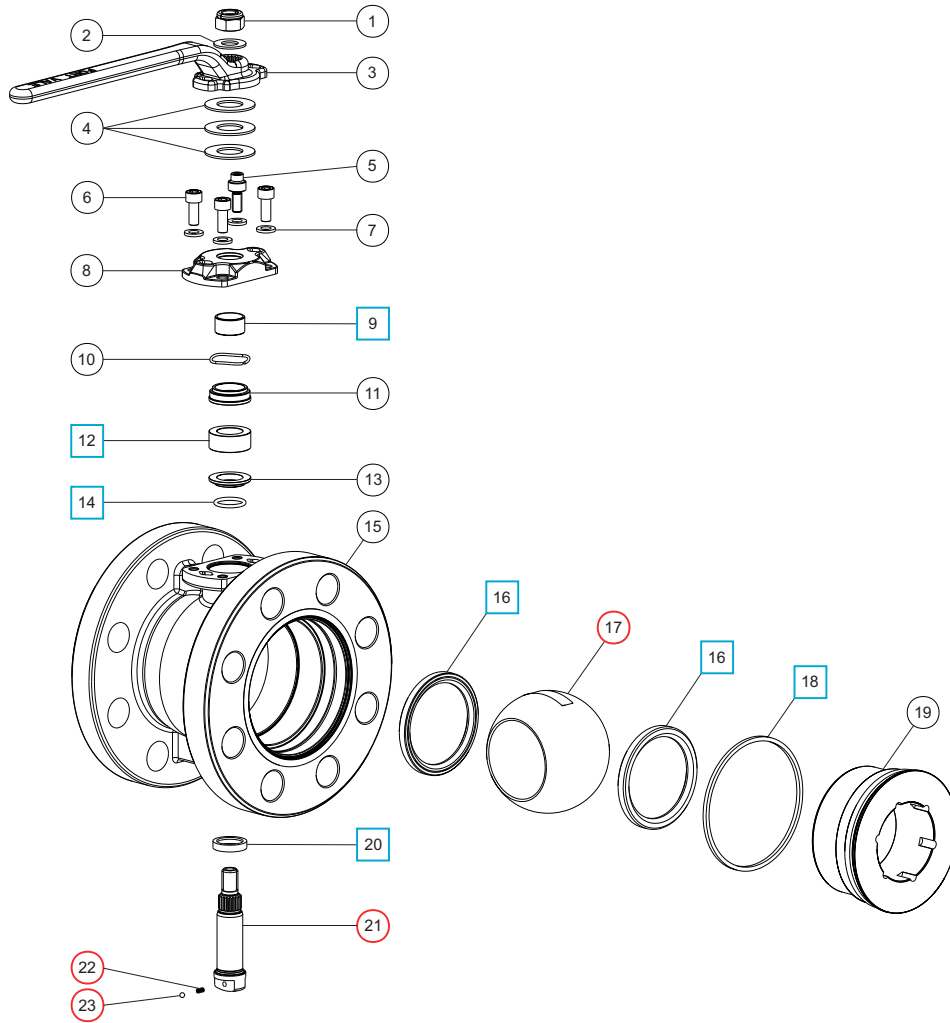

Parts List

Item	Description	Part No.
1	M10 locking nut *Note	5112-008-XX
2	M10 washer	5113-009
3	Handle	370/0125
4	16mm Belleville washer (3)	5113-038
5	Stop pin *Note	370/3442-XX
6	M6 cap screw (3) *Note	5111-108-XX
7	M6 spring washer (4)	5113-008
8	Retaining gland *Note	370/3449XX
9	Bearing bush	370/3443 <input type="checkbox"/> <input type="radio"/>
10	Wave spring	370/3457
11	Stuffing gland	370/3458
12	Gland seal	370/3353 <input type="checkbox"/> <input type="radio"/>
13	Stuffing gland	370/3459
14	Perfluoroelastomer O ring	5005-216PER <input type="checkbox"/> <input type="radio"/>
15	2" ball valve body *Note	370/5001XX
16	TFM PTFE ball seal (2)	370/0102FS <input type="checkbox"/> <input type="radio"/>
17	Ball *Note	370/3301XX <input type="radio"/>

Parts List

Item	Description	Part No.
18	Body seal	370/0106GR <input type="checkbox"/> <input type="radio"/>
19	Seal retainer	370/5003
20	Bottom bearing	370/0104FS <input type="checkbox"/> <input type="radio"/>
21	Spindle	370/0120FS <input type="radio"/>
22	Plunger spring	370-3469 <input type="radio"/>
23	3mm ball	10154SS <input type="radio"/>

NOTE: The valve specification changes the part number

Seal Kit - All parts marked in the Parts List

Description	Part No.
For fire safe & lethal service valves	370/50LSK

Repair Kit - All parts marked in the Parts List

Description	Part No.
For fire safe valves only	370/50FRK
For lethal service valves only	370/50LRK



2" Fire Safe Ball Valve

Part No: 370/0100FSX

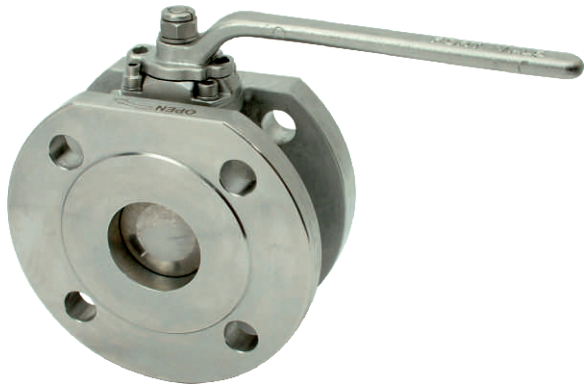

Specification

Nominal size

50mm

Tank connection

Flanged: 4 x 18mm holes on a 125mm PCD

Outlet/Process connection

Flanged: 4 x 18mm holes on a 125mm PCD

Properties

Refer to Design Conditions: NOTE

Options

Left or right hand operation

Materials

Contact parts: 316 stainless steel

Main seal: TFM PTFE

Design Conditions

Weight:	7.64 Kg
Design Pressure (MAWP):	16 Bar
Test Pressure:	24 Bar
Design Temperature Min:	-40°C
Design Temperature Max:	205°C

NOTE: This fire safe specification ball valve is not compatible with lethal service conditions.

Design Codes

BS EN14432, EN12516-2, EN10497
API 607

Range

Description	Part No.
2" fire safe valve, left hand	370/0100FSL
2" fire safe valve, right hand	370/0100FSR

Related Parts

Description	Part No.
Stainless steel/graphite spiral wound gasket: 2" ball valve inlet and outlet	5005-724SP

Section View

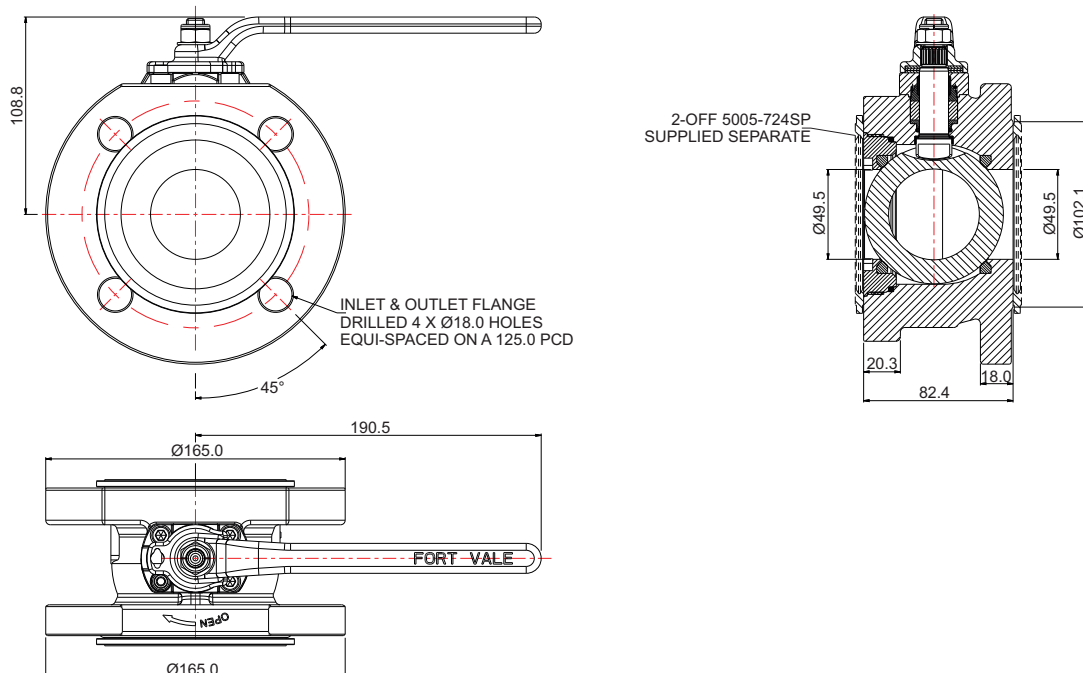



2" Fire Safe Ball Valve

Part No: 370/0100FSX

Parts Drawing

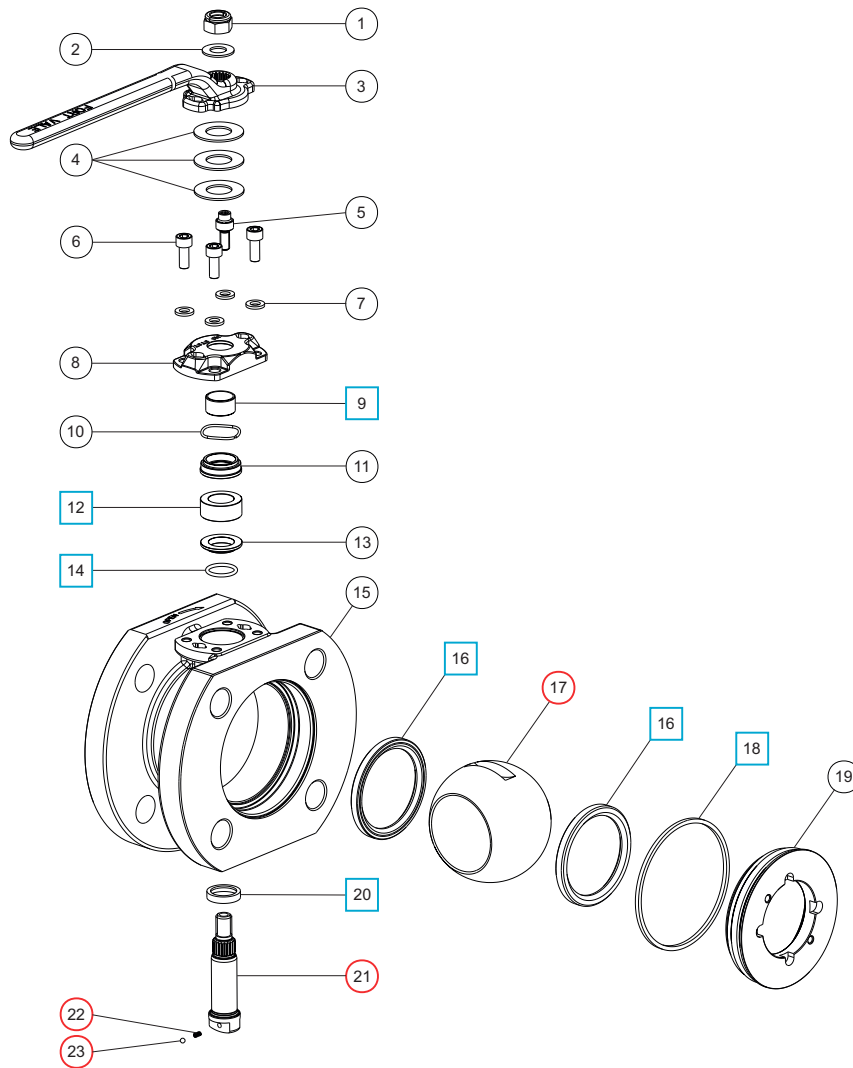

Parts List

Item	Description	Part No.
1	M10 locking nut	5112-008
2	M10 washer	5113-009
3	Handle	370/0125
4	16mm Belleville washer (3)	5113-038
5	Stop pin	370/3442
6	M6 cap screw (3)	5111-108
7	M6 spring washer (4)	5113-008
8	Retaining gland	370/3449
9	Bearing bush	370/3443 □ ○
10	Wave spring	370/3457
11	Stuffing gland	370/3458
12	Gland seal	370/3353 □ ○
13	Stuffing gland	370/3459
14	Perfluoroelastomer O ring	5005-216PER □ ○
15	2" ball valve body	370/0110FS
16	TFM PTFE ball seal (2)	370/0102FS □ ○
17	Ball	370/3301 ○

Parts List

Item	Description	Part No.
18	Body seal	370/0106GR □ ○
19	Seal retainer	370/0176/2
20	Bottom bearing	370/0104FS □ ○
21	Spindle	370/0120FS ○
22	Plunger spring	370-3469 ○
23	3mm ball	10154SS ○

Seal Kit - All parts marked □ in the Parts List

Description	Part No.
For fire safe & lethal service valves	370/50LSK

Repair Kit - All parts marked ○ in the Parts List

Description	Part No.
For fire safe valves only	370/50FRK



3" Fire Safe / Lethal Service Ball Valve

Part No: 360/5000XXX

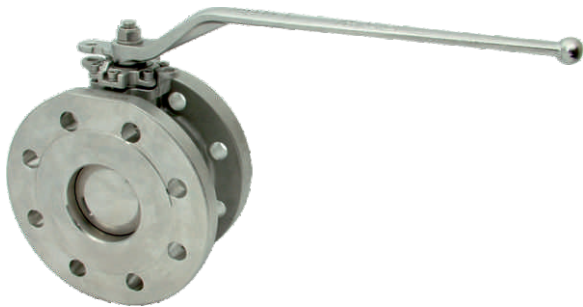

Specification

Nominal size

80mm

Tank connection

Flanged: 8 x 18mm holes on a 160mm PCD

Outlet/Process connection

Flanged: 8 x 18mm holes on a 160mm PCD

Options

Fire safe specification or lethal service specification - refer to Design Conditions: NOTE

Left or right hand operation

Materials

Contact parts: 316 stainless steel

Main seal: TFM PTFE

Design Conditions

Weight:	17.0 Kg
Design Pressure (MAWP):	16 Bar
Test Pressure:	24 Bar
Design Temperature Min:	-40°C
Design Temperature Max:	205°C

NOTE: The fire safe specification ball valve is not compatible with lethal service conditions. The lethal service specification ball valve is compatible with fire safe and lethal service conditions.

Design Codes

BS EN14432, EN12516-2, EN10497
API 607

Range

Description	Part No.
3" fire safe valve, left hand	360/5000FSL
3" fire safe valve, right hand	360/5000FSR
3" fire safe/lethal service valve, left hand	360/5000LSL
3" fire safe/lethal service valve, right hand	360/5000LSR

Related Parts

Description	Part No.
Stainless steel/graphite spiral wound gasket: 3" ball valve inlet and outlet	5005-630SP

Section View

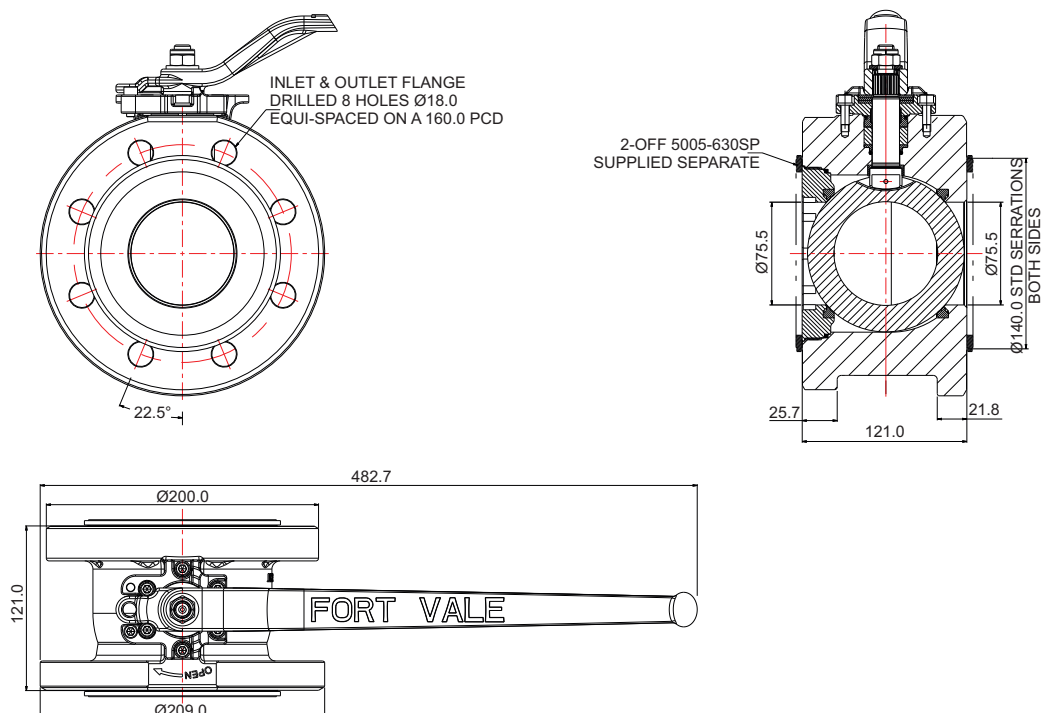



3" Fire Safe / Lethal Service Ball Valve

Part No: 360/5000XXX

Parts Drawing

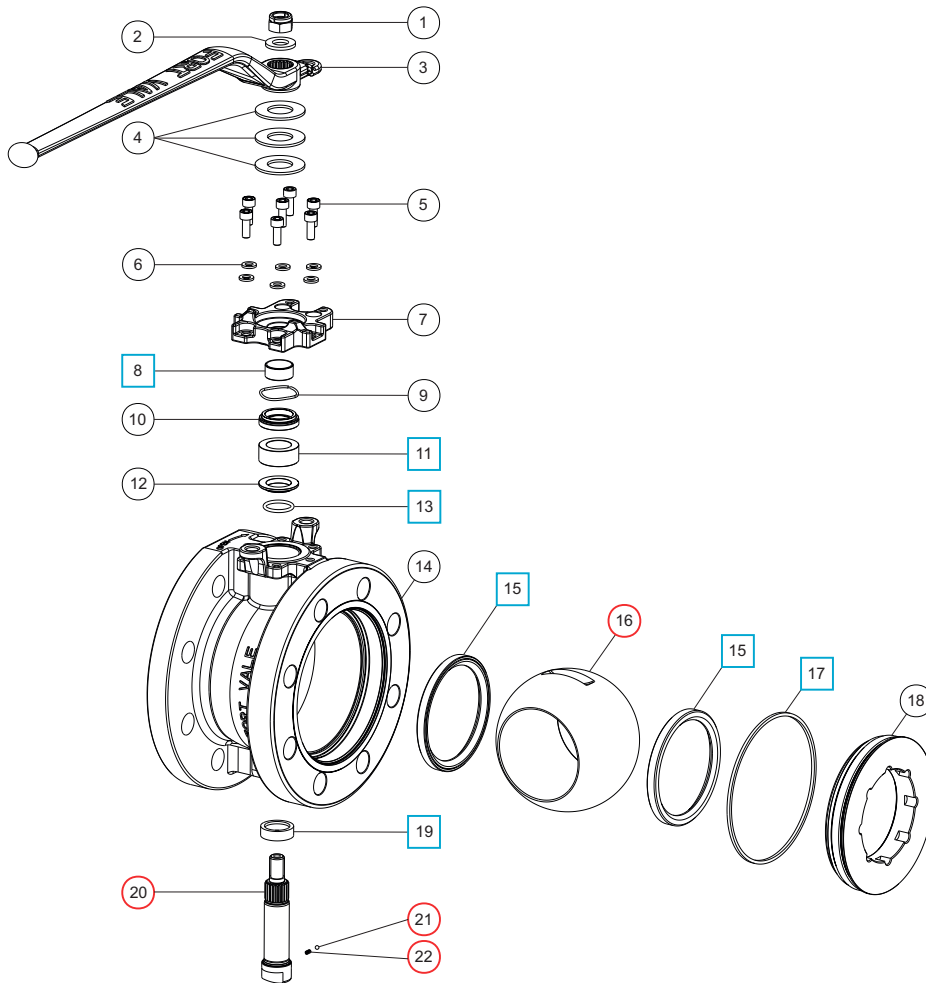

Parts List

Item	Description	Part No.
1	M12 locking nut *Note	5112-007-XX
2	M12 washer	5123-003
3	Handle	360/3416FS
4	20mm Belleville washer (3)	5113-041
5	M6 cap screw (7) *Note	5111-015-XX
6	M6 spring washer (6)	5113-008
7	Retaining gland *Note	360/5005XX
8	Bearing bush	360/0182 □ ○
9	Wave spring	360/3351
10	Stuffing gland	360/0180
11	Gland seal	360/3353 □ ○
12	Stuffing gland	360/0181
13	Perfluoroelastomer O ring	5005-928HT □ ○
14	3" ball valve body *Note	360/5014XX
15	TFM PTFE ball seal (2)	360/3402FS □ ○
16	Ball *Note	360/3401XX ○
17	Body seal	360/0106GR □ ○

Parts List

Item	Description	Part No.
18	Seal retainer	360/0176/2
19	Bearing bush	360/3421FS □ ○
20	Spindle	360/3422FS ○
21	3mm ball	10154SS ○
22	Plunger spring	370-3469 ○

NOTE: The valve specification changes the part number

Seal Kit - All parts marked □ in the Parts List

Description	Part No.
For fire safe & lethal service valves	360/50LSK

Repair Kit - All parts marked ○ in the Parts List

Description	Part No.
For fire safe valves only	360/50FRK
For lethal service valves only	360/50LRK



APPENDIX

Catalogue

A	Bolt Torque Guide & Step Loading Procedure
B	Client Responsibilities - Valves & Accessories



Bolt Torque Guide & Step Loading Procedure

Installation & Operating Instructions

Flange Bolting

CAUTION: Weld-distortion and too much tightening force will cause damage to a flange.

It is important not to cause damage to weld-in flanges and mating flanges. If a flange is damaged it will not give a satisfactory seal when a gasket and secondary mating flange is installed.

Bolt-stress can decrease after initial tightening. The cause can be deformation of the gasket material, particularly with soft materials such as a CNAF/PTFE envelope gasket.

Best procedure recommends that, after initial bolting, the flange joint is tightened again after a period of time. Most gasket manufacturers advise a period of 24 hours. ASME PCC-1-2000 GUIDELINES FOR PRESSURE BOUNDARY BOLTED FLANGE JOINT ASSEMBLY advises a minimum period of 4 hours.

Bolt torque calculations are based on a flat flange to within 0.15mm.

Recommended bolt torque values will be reduced if a lubrication is used.

Bolt Torque

Bolt Torque Values

Fort Vale bolt torque values are given as a reference guide only and are based on:

- The use of a CNAF/PTFE gasket.
- Unlubricated fasteners.
- A flange flat to within 0.15mm.

CAUTION: If you use a different gasket material, a lubricant, a flange with distortion, you must re-calculate the torque value.

Bolt Torque Procedure

To install flanged parts correctly:

- Examine the mating flange of the part.
- If the flange is marked with a torque value, obey that torque value.
- If there is no torque value marked on the mating flange, obey the bolt torque values given in Table BT1.
- Tighten the bolts evenly in sequence. See Figure BT1.
- Obey the Step Loading Procedure (ASME PCC-1-2000). See next page.

Table BT1

Thread	Torque Value
M10	30 Nm (22 lbf.ft)
M12	65 Nm (48 lbf.ft)
M16	81 Nm (60 lbf.ft)

Figure BT1

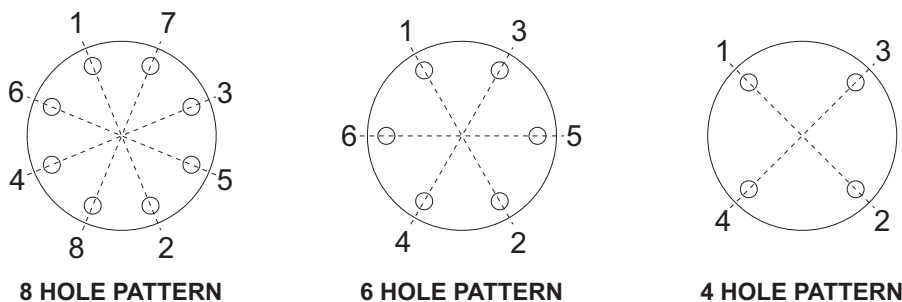



Bolt Torque Guide & Step Loading Procedure

Installation & Operating Instructions

Step Loading Procedure

To install flanged parts correctly, obey the Step Loading Procedure extract from ASME PCC-1-2000:

Install

Hand tighten, then “snug up” to 15 Nm (10 lbf.ft) to 30 Nm (20 lbf.ft) (not to exceed 20% of Target Torque). Check flange gap around circumference for uniformity. If the gap around the circumference is not reasonably uniform, make the appropriate adjustments by selective tightening before proceeding.

Round 1

Tighten to 20% to 30% of Target Torque. Check flange gap around circumference for uniformity. If the gap around the circumference is not reasonably uniform, make the appropriate adjustments by selective tightening before proceeding.

Round 2

Tighten to 50% to 70% of Target Torque. Check flange gap around circumference for uniformity. If the gap around the circumference is not reasonably uniform, make the appropriate adjustments by selective tightening before proceeding.

Round 3

Tighten to 100% of Target Torque. Check flange gap around circumference for uniformity. If the gap around the circumference is not reasonably uniform, make the appropriate adjustments by selective tightening before proceeding.

Round 4

Continue tightening the bolts, but on a rotational clockwise pattern until no further nut rotation occurs at the Round 3 Target Torque value. For indicator bolting, tighten bolts until the indicator rod retraction readings for all bolts are within the specified range.

Round 5

Time permitting, wait a minimum of 4 hr and repeat Round 4; this will restore the short-term creep relaxation/embedment losses. If the flange is subjected to a subsequent test pressure higher than its rating, it may be desirable to repeat this round after the test is completed.



Client Responsibilities - Valves & Accessories

Installation, Operation & Maintenance Instructions

Compatibility

Make sure that the function and technical specification of the valve/accessory is compatible with the vessel service conditions and the cargo. This includes, but is not limited to:

- dimensions
- pressure/vacuum setting
- air/gas/liquid flow capacity
- maximum allowable working pressure
- test pressure
- minimum/maximum design temperatures
- materials of construction.

Maintenance

Fort Vale valves and accessories have a long life if you use them correctly in compatible service conditions. It is not necessary to lubricate the parts, but we recommend that you obey the precautions that follow:

Visual checks at regular intervals:

1. Examine the valve to make sure there is no damage, wear or corrosion.
2. Examine the valve and adjacent area to make sure there is no leakage of cargo.
3. Examine the fasteners to make sure they are not loose.
4. Make sure the valve operates correctly.

CAUTION: If you operate the valve with very corrosive cargo, or near its temperature and/or pressure limit (very high or very low temperature and/or pressure), do the visual checks more frequently.

As well as the visual checks, schedule suitable maintenance intervals for the valve based on how frequently the valve is used, the type of cargo and the service conditions.

After 2½ years of service, do the checks that follow:

1. Examine the valve to make sure there is no damage, wear or corrosion.
2. Make sure the valve operates correctly.
3. Do a pressure test on the valve.

After 5 years of service do the checks that follow:

1. Disassemble and clean the valve.
2. Replace all the valve seals.

Replacement Parts

Do not adapt or change the valve. If you install a replacement part, it must be a genuine Fort Vale part.

WARNING: If you install a part that is not a genuine Fort Vale part, there is a risk of:

- injury to personnel
- permanent damage to the valve
- permanent damage to the vessel
- valve malfunction.

External Fire

If the valve is installed in an area where there is a risk of external fire, you must install compatible accessories to prevent damage to the valve.

Compatibility of Accessories

An accessory component must cause no interference with the valve function. It must be made from compatible materials that will not cause damage to the valve materials. Do not install an accessory that will cause an increased load on the valve, i.e. mechanical, static, dynamic, thermal.

Mis-use

Obey the instructions and recommended procedures in the installation and operating instructions. Obey the pressure and temperature markings on the valve and on the drawing. Use the valve/accessory for its correct function only. Fort Vale accept no liability or responsibility for incorrect use of the valve/accessory.



Our subsidiaries are located in:

US Office

126 N. Virginia
La Porte
TX 77571
USA

Tel: +1 281 471 8100

Fax: +1 281 471 8116

Email: ussales@fortvale.com

Head Office

Calder Vale Park
Simonstone Lane
Simonstone, Burnley
Lancashire, BB12 7ND, UK

Tel: +44 (0) 1282 687120

Fax: +44 (0) 1282 687110

Email: sales@fortvale.com

China Office

Fort Vale Engineering Shanghai Ltd
Building 11 88 Yuanshan Road
Xinzhuang Industry Park
Shanghai 201108 China

Tel: +86 21 6442 1367

Fax: +86 21 6442 1376

Email: cnsales@fortvale.com

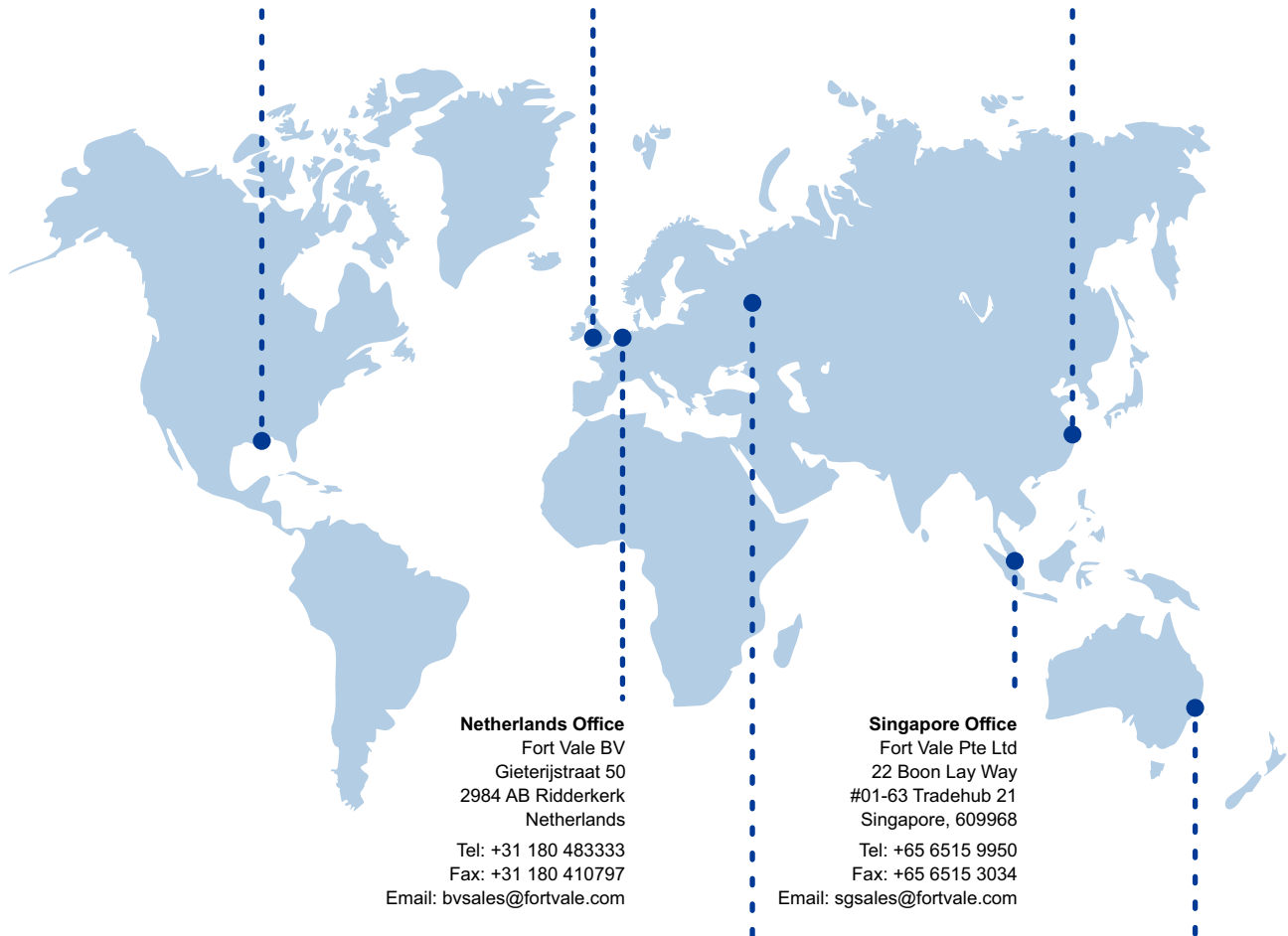

Netherlands Office

Fort Vale BV
Gieterijstraat 50
2984 AB Ridderkerk
Netherlands

Tel: +31 180 483333

Fax: +31 180 410797

Email: bvsales@fortvale.com

Singapore Office

Fort Vale Pte Ltd
22 Boon Lay Way
#01-63 Tradehub 21
Singapore, 609968

Tel: +65 6515 9950

Fax: +65 6515 3034

Email: sgsales@fortvale.com

Russia Office

Fort Vale Russian Federation
3 Moskovski Shossee
Office 11, Sergeev Posad
Moscow Region 141304
Russian Federation

Tel: +7 916 682 0947

+7 926 538 7289

Email: rw@fortvale.ru

Australia Office

Fort Vale Australia Pty Ltd
Bellwood Business Park
Unit 14, 49 Bellwood Street
Darra, Queensland, 4076

Tel: +61 7 3189 5059

Email: ausales@fortvale.com

We also have Authorised Distributors around the world to provide you with product sales and after-market services. To find your nearest distributor, please visit our website - www.fortvale.com

