

Specification

Nominal size/body angle

3" / 90°

Inlet connection

Flanged: 8 x 14mm holes on a 178mm PCD

Outlet connection

Flanged: 4 x 17mm holes on a 160mm PCD

Materials

Seating area: Superseat (alloy 625)

Contact parts: 316 stainless steel

Main seal: Fortyt

Alternatives are available, refer to the Design Options page

Design Conditions

Weight:	15.0 Kg
Design Pressure (MAWP):	4 Bar
Test Pressure:	7.3 Bar
Design Temperature Min:	-40°C
Design Temperature Max:	200°C

NOTE: The Design Conditions and Section View dimensions are for the specified part number only.

Approvals

BS EN14433

Design Approval by Lloyds Register of Shipping

Range

Description	Part No.
Standard body, manually operated	844/3000A
Extended body, manually operated	844/7400A
Standard body, pneumatically actuated	844/3080ASS
Extended body, pneumatically actuated, slotted outlet	844/7700ASS

Related Parts

Description	Part No.
Weld-in flange	324/9000
Stud kit	845/2040
Bolting kit - 4 hole outlet	311/3000
CNAF/PTFE inlet gasket	5005-015
CNAF/PTFE outlet gasket	5005-049
Valve operation decal	845/0320

Section View

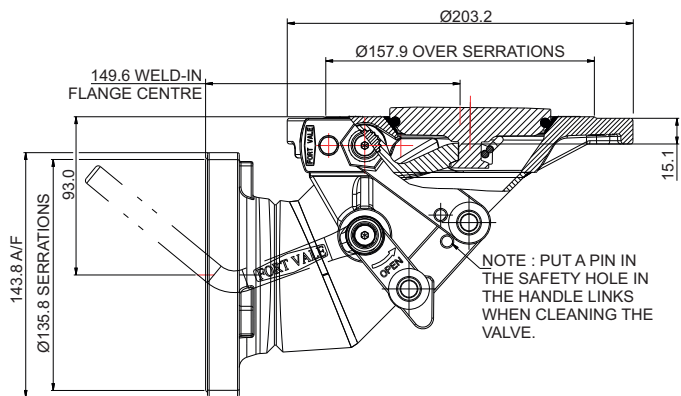
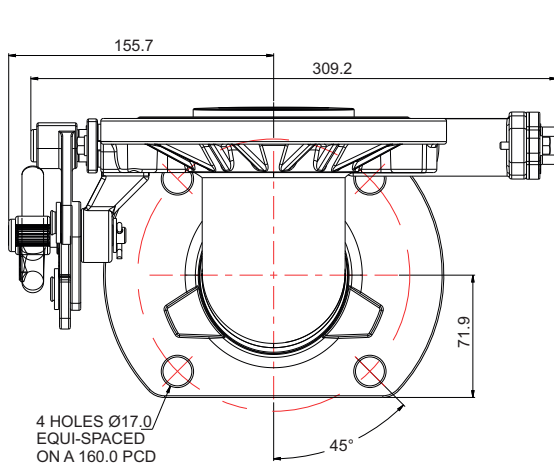

Parts Drawing

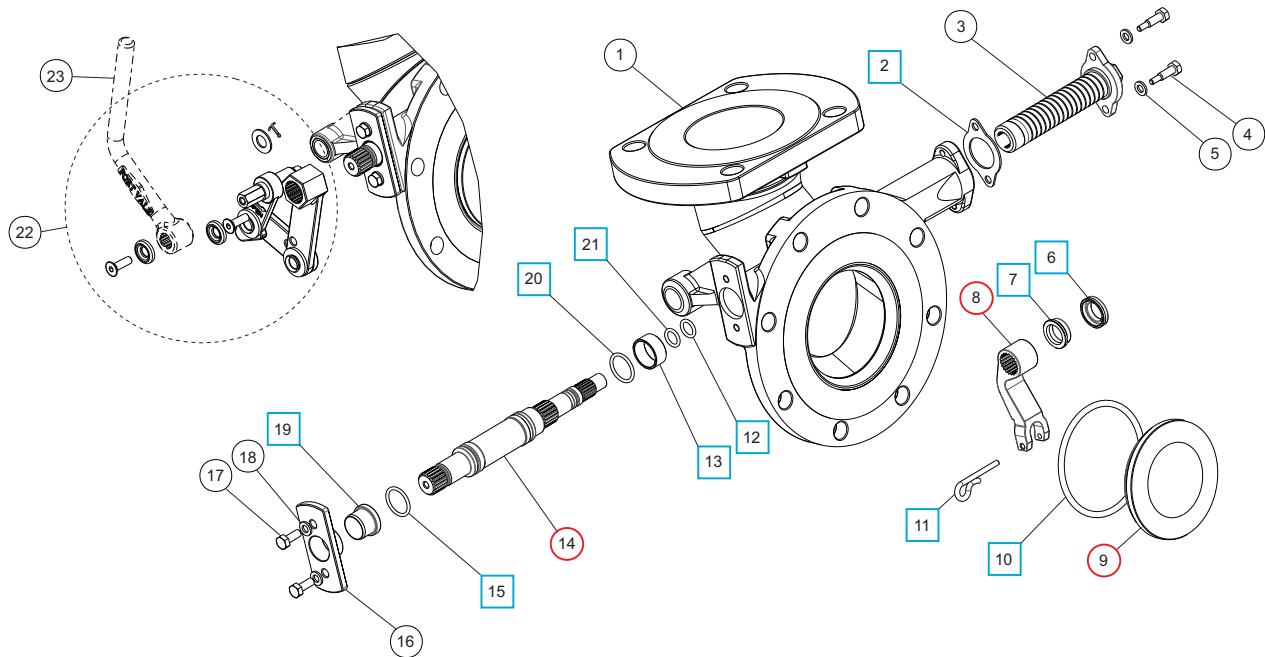

Parts List

Item	Description	Part No.
1	Body	844/2075B
2	Spring boss gasket	5005-845 <input type="checkbox"/> <input type="radio"/>
3	Spring assembly	845/0050
4	Clamp screw (2)	845/0017
5	Spring washer (2)	5113-008
6	Bush seal	845/0064 <input type="checkbox"/> <input type="radio"/>
7	Seal energizer	845/0063 <input type="checkbox"/> <input type="radio"/>
8	Lifting fork	845/0010 <input type="radio"/>
9	Poppet	845/0040 <input type="radio"/>
10	Fortyt O ring	5005-104 <input type="checkbox"/> <input type="radio"/>
11	Retaining pin	845/0015 <input type="checkbox"/> <input type="radio"/>
12	Perfluoroelastomer O ring	10133PHT <input type="checkbox"/> <input type="radio"/>
13	Spindle bearing	845/0062 <input type="checkbox"/> <input type="radio"/>
14	Spindle	845/0200 <input type="radio"/>
15	Viton O ring	5005-336 <input type="checkbox"/> <input type="radio"/>
16	Stuffing clamp	845/0016
17	Clamp bolt (2)	5111-022
18	Spring washer (2)	5113-008
19	Stuffing seal	845/0061 <input type="checkbox"/> <input type="radio"/>
20	Perlast O ring	5005-384 <input type="checkbox"/> <input type="radio"/>
21	PTFE O ring	5005-008 <input type="checkbox"/> <input type="radio"/>
22	Handle linkage assembly	324/8910
23	Handle *Refer to the Handle Options Table	

Footvalve Handle Options

Specification	Type	Part No.
Std. Cleanflow handle		324/8670
Std. Highlift handle		330/5010

Seal Kit

Description	Part No.
All parts marked <input type="checkbox"/> in the Parts List	845/00SK

Repair Kit

Description	Part No.
All parts marked <input type="radio"/> in the Parts List	845/00RK