



Specification

Nominal size/body angle
80mm / 45°

Inlet connection

Flanged: 8 x 14mm holes equi-spaced on a 178mm PCD

Outlet connection

Flanged: 4 x 17mm holes on a 160mm PCD

Materials

Seating area: Superseat (alloy 625)

Contact parts: 316 stainless steel

Main seal: Fortyt

Alternatives are available, refer to the Design Options page

Design Conditions

Weight:	8.9 Kg
Design Pressure (MAWP):	4 Bar
Test Pressure:	6 Bar
Design Temperature min:	-40°C
Design Temperature max:	200°C

NOTE: The Design Conditions and Section View dimensions are for the specified part number only.

Approvals

BS EN14433

Design Approval by Lloyds Register of Shipping

Range

Description	Part No.
Standard specification	826/1200A
With alloy C276 seating area	826/1200AHS

Related Parts

Description	Part No.
Tank weld-in flange	324/9000
Stud kit	324/2070
Bolting kit - 4 hole outlet	311/3500
CNAF/PTFE inlet gasket	5005-015
CNAF/PTFE outlet gasket	5005-049
Valve operation decal	326/0300

Section View

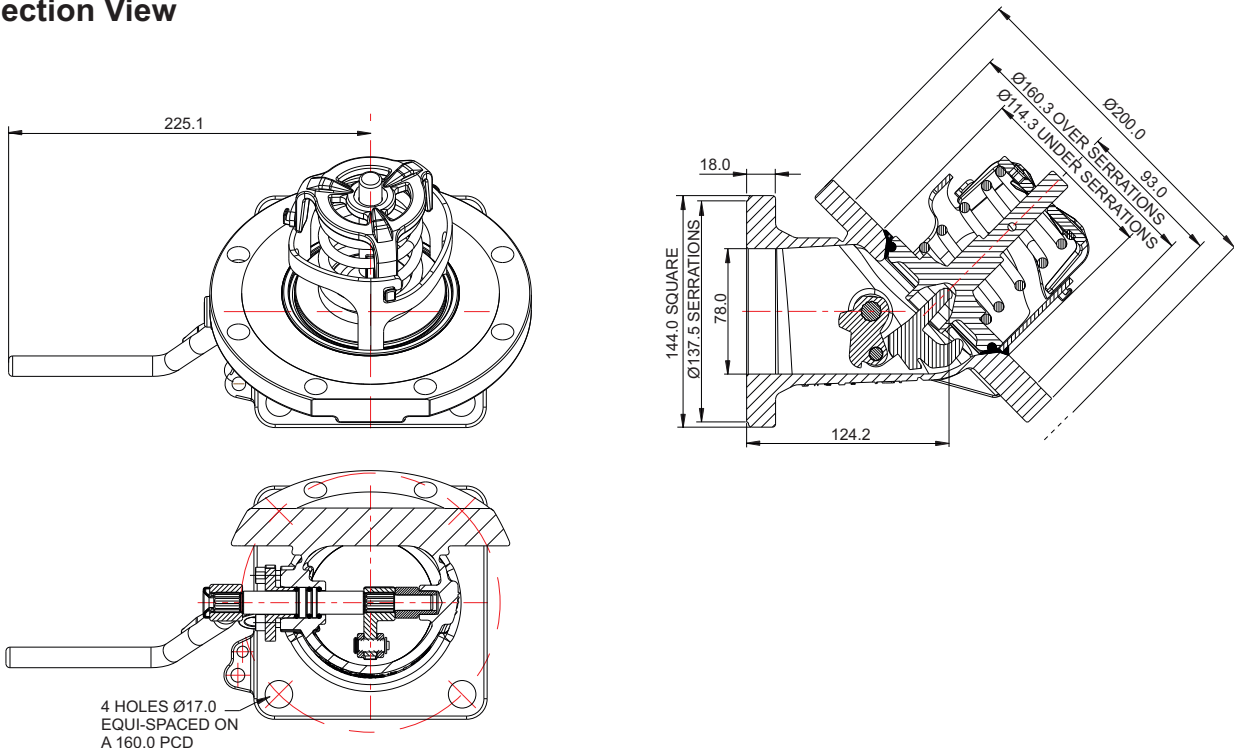

Parts Drawing

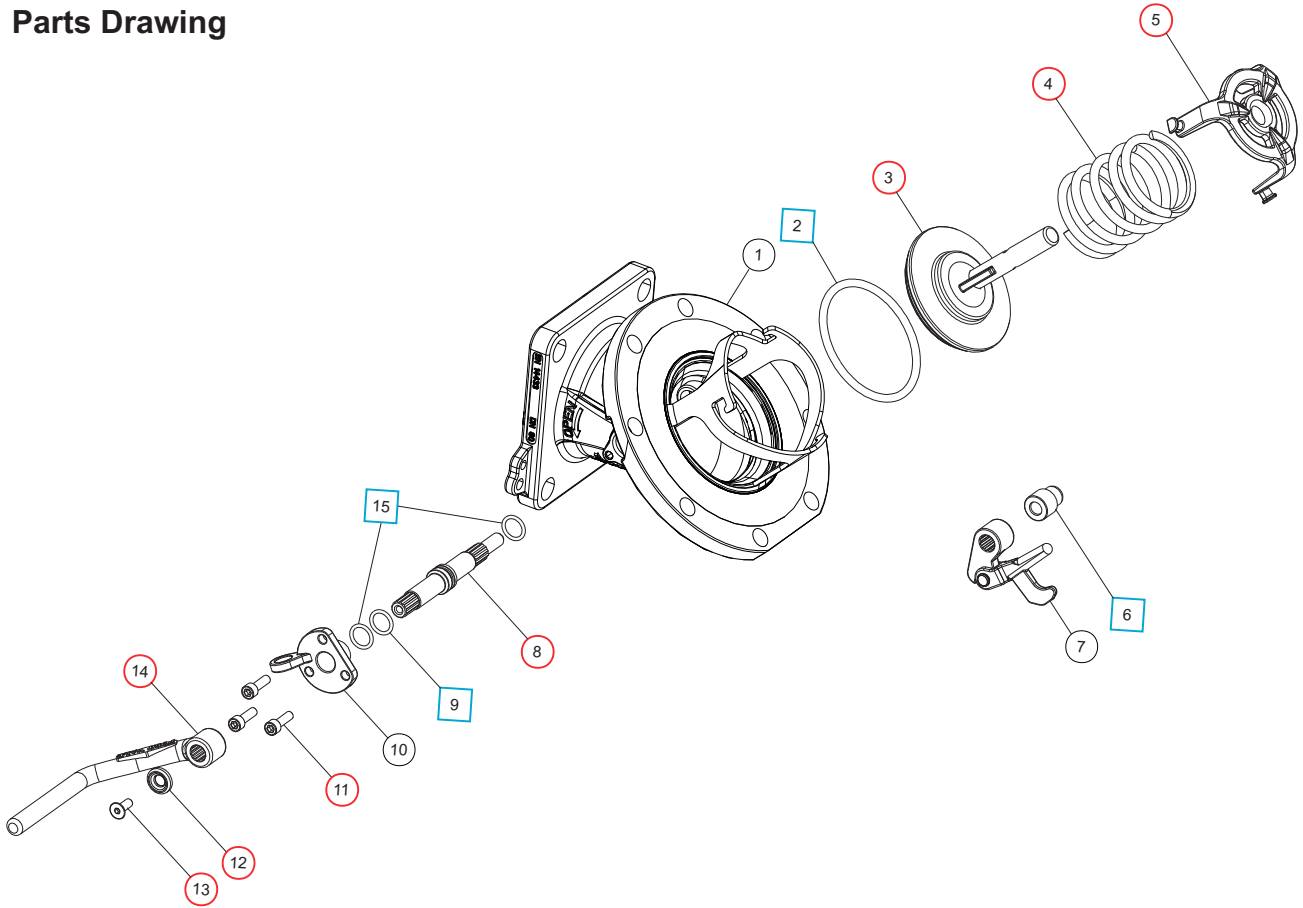

Parts List

Item	Description	Part No.
1	Body	826/1100B
2	Fortyt O ring	5005-104 <input type="checkbox"/> <input type="radio"/>
3	Solid poppet	324/2020 <input type="radio"/>
4	Spring	5104-971 <input type="radio"/>
5	Spring top plate	290/6104 <input type="radio"/>
6	PTFE crankshaft end bush	20362 <input type="checkbox"/> <input type="radio"/>
7	Crank block assembly	821/0300
8	Spindle	821/0010 <input type="radio"/>
9	Viton O ring	20361 <input type="checkbox"/> <input type="radio"/>
10	Stuffing clamp	324/1001
11	M6 capscrew (3)	5111-017 <input type="radio"/>
12	Handle retaining washer	20370 <input type="radio"/>
13	Handle retaining screw	5111-030 <input type="radio"/>
14	Handle	330/5010 <input type="radio"/>
15	PTFE O ring (2)	20363 <input type="checkbox"/> <input type="radio"/>

Seal Kit

Description	Part No.
All parts marked <input type="checkbox"/> in the Parts List	826/00SK

Repair Kit

Description	Part No.
All parts marked <input type="radio"/> in the Parts List	826/00RKA

Spare Parts

Description	Type	Part No.
Spindle & crank block assy Item 6, 7, 8, 9, & 15		821/0200