

Specification

Nominal size/body angle
80mm / 45°

Inlet connection

Flanged: 8 x 14mm holes equi-spaced on a 178mm PCD

Outlet connection

Flanged: 4 x 17mm holes on a 160mm PCD

Materials

Seating area: Superseat (alloy 625)

Contact parts: 316 stainless steel

Main seal: Fortyt

Alternatives are available, refer to the Design Options page

Design Conditions

Weight:	9.87 Kg
Design Pressure (MAWP):	4 Bar
Test Pressure:	6 Bar
Design Temperature min:	-40°C
Design Temperature max:	200°C

NOTE: The Design Conditions and Section View dimensions are for the specified part number only.

Approvals

BS EN14433

Design Approval by Lloyds Register of Shipping

Range

Description	Part No.
Standard specification	845/1200A
With alloy C276 seating area	845/1200AHS

Related Parts

Description	Part No.
Tank weld-in flange	324/9000
Stud kit	845/2040
Bolting kit - 4 hole outlet	311/3500
Bolting kit - 6 hole outlet	360/0300
CNAF/PTFE inlet gasket	5005-015
CNAF/PTFE outlet gasket	5005-049
CNAF/PTFE outlet gasket - 6 hole	5005-169
Valve operation decal	845/0320

Section View

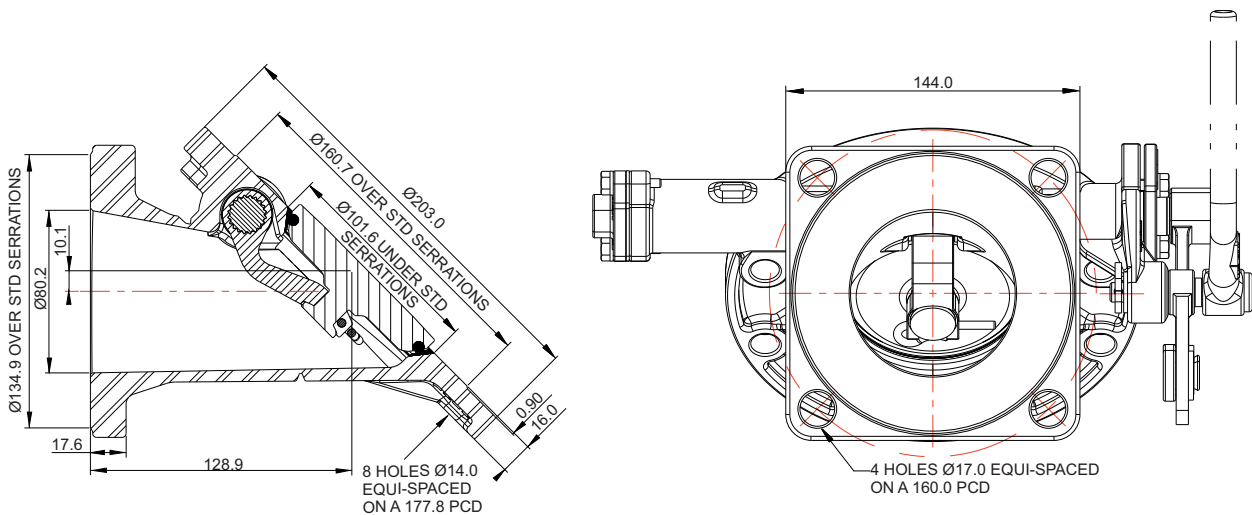

Parts Drawing

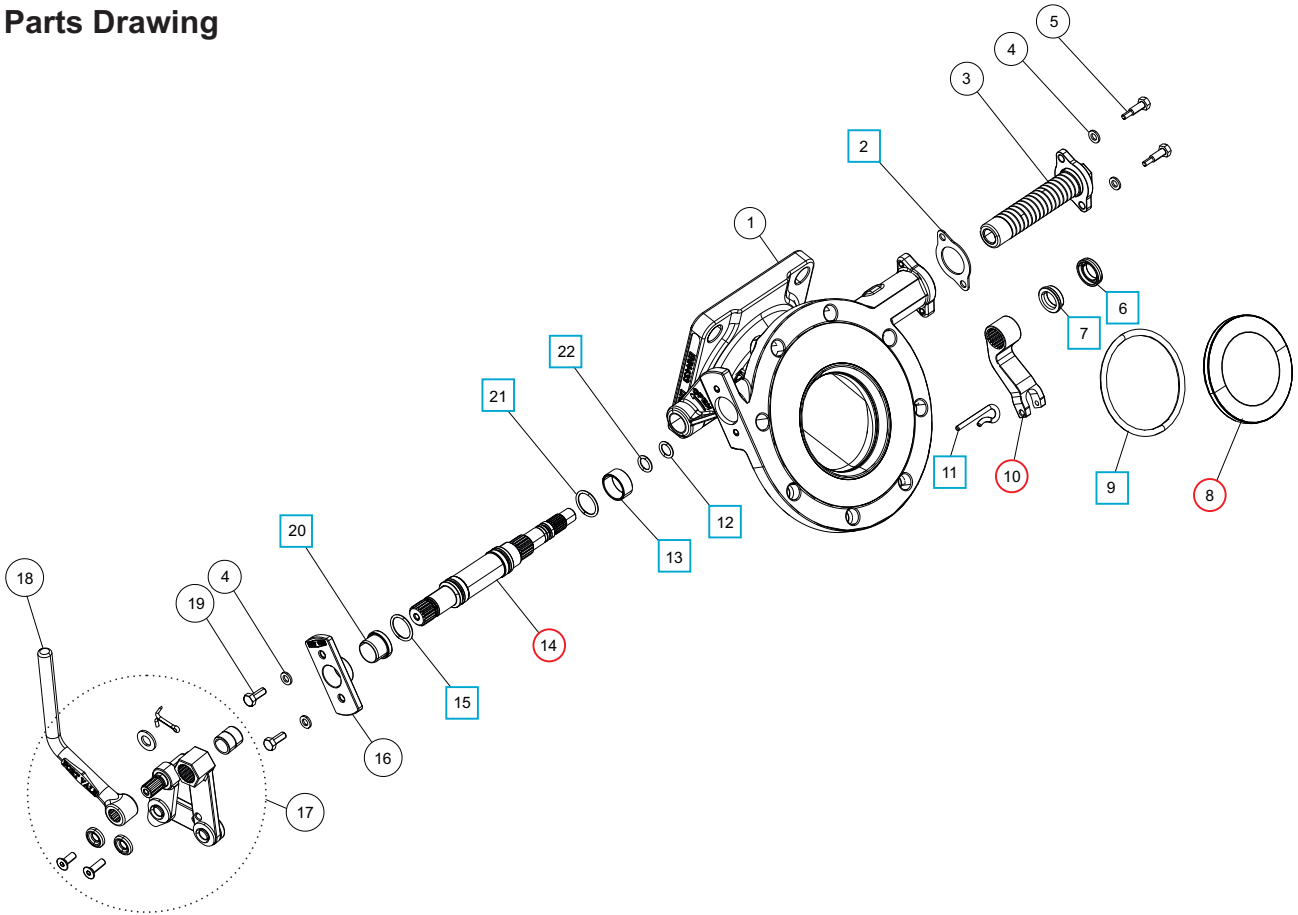

Parts List

Item	Description	Part No.
1	Body	845/1100B
2	Spring housing gasket	5005-845 <input type="checkbox"/> <input type="radio"/>
3	Spring assembly	845/0050
4	M6 spring washer (4)	5113-008
5	M6 hex bolt (2)	845/0017
6	Bush seal	845/0064 <input type="checkbox"/> <input type="radio"/>
7	Seal energizer	845/0063 <input type="checkbox"/> <input type="radio"/>
8	Poppet	845/0040 <input type="radio"/>
9	Fortyt O ring	5005-104 <input type="checkbox"/> <input type="radio"/>
10	Lifting fork	845/0010 <input type="radio"/>
11	Retaining pin	845/0015 <input type="checkbox"/> <input type="radio"/>
12	Perlast O ring	10133PHT <input type="checkbox"/> <input type="radio"/>
13	Spindle bearing	845/0062 <input type="checkbox"/> <input type="radio"/>
14	Spindle	845/0200 <input type="radio"/>
15	Viton O ring	5005-336 <input type="checkbox"/> <input type="radio"/>
16	Stuffing clamp flange	845/0016
17	Handle linkage assembly	324/8910
18	Handle *Refer to Handle Options Table	
19	M6 X 16mm hex bolt (2)	5111-022
20	Stuffing seal	845/0061 <input type="checkbox"/> <input type="radio"/>
21	Perlast O ring	5005-384 <input type="checkbox"/> <input type="radio"/>
22	PTFE O ring	5005-008 <input type="checkbox"/> <input type="radio"/>

Footvalve Handle Options

Specification	Type	Part No.
Std. Cleanflow handle		324/8670
Cranked Cleanflow handle		324/8671
Std. Highlift handle		330/5010

Seal Kit

Description	Part No.
All parts marked <input type="checkbox"/> in the Parts List	845/00SK

Repair Kit

Description	Part No.
All parts marked <input type="radio"/> in the Parts List	845/00RK