



## Specification

### Nominal size

50mm

### Tank connection

Flanged: 4 x 18mm holes on a 126mm PCD

### Outlet/process connection

Flanged: 4 x 18mm slots on a 120 - 127mm PCD

### Options

Left hand operated, handle with TIR

### Materials

Contact parts: PFA lined

Main seal: PTFE

Refer to Range for other PFA Lined Ball Valves

Alternatives are available, refer to the Design Options page

## Design Conditions

|                         |          |
|-------------------------|----------|
| Weight:                 | 9.76 Kg  |
| Design Pressure (MAWP): | 6.9 Bar  |
| Test Pressure:          | 12.6 Bar |
| Design Temperature Min: | -40°C    |
| Design Temperature Max: | 200°C    |

**NOTE:** The Design Conditions and Section View dimensions are for the specified part number only.

### Design Codes

BS EN14432

RID

## Range

| Description                             | Part No.    |
|---|-------------|
| 25mm reduced bore ball valve PFA lined  | 530/P100    |
| 50mm full bore ball valve PFA lined     | 370/P200    |
| 50mm ball valve PFA lined, painted body | 370/P200PA  |
| 80mm full bore ball valve PFA lined     | 360/P030X * |

\*The part number changes for left or right hand operated

## Related Parts

| Description            | Part No.    |
|------------------------|-------------|
| Stud kit               | 311/3790    |
| Bolting kit            | 311/3590    |
| PFA lined blind flange | 370/4239PFA |

## Section View

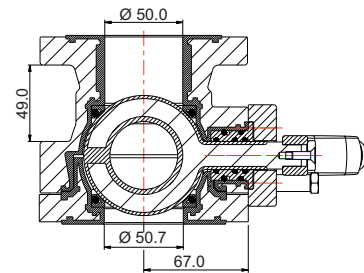
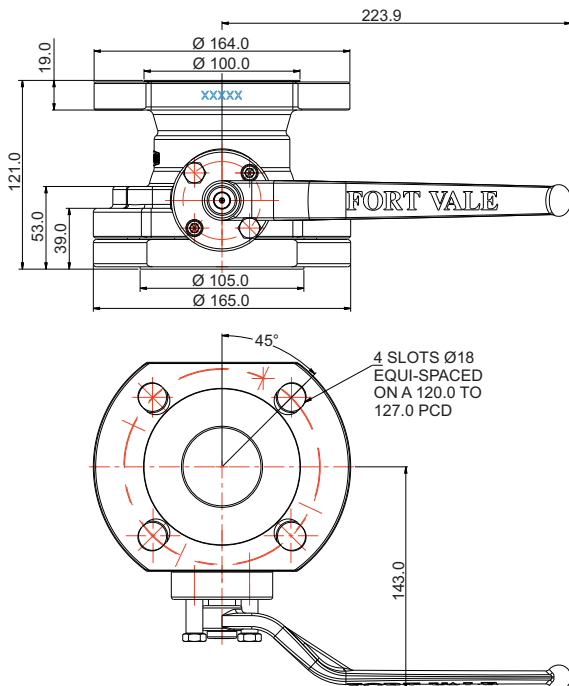

## Parts Drawing

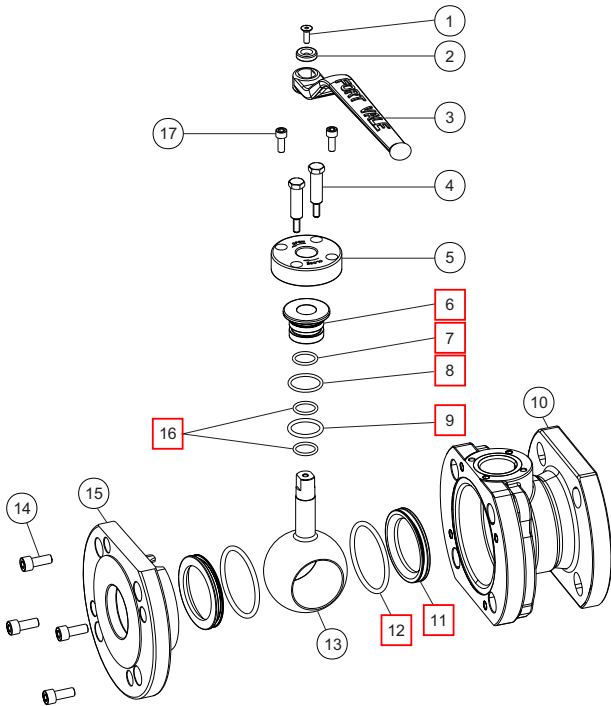

## Parts List

| Item | Description                   | Part No.     |   |
|------|-------------------------------|--------------|---|
| 1    | M5 screw                      | 5111-113     |   |
| 2    | Retaining washer              | 20370/5      |   |
| 3    | Handle                        | 370/3306/1   |   |
| 4    | Stop pin (2)                  | 370/P107     |   |
| 5    | Stuffing plate                | 370/P114     |   |
| 6    | Seal carrier                  | 370/P113     | ☐ |
| 7    | Viton O ring                  | ORB115VL     | ☐ |
| 8    | Viton O ring                  | ORB121VL     | ☐ |
| 9    | Perfluoroelastomer O ring     | 5005-214PER  | ☐ |
| 10   | PFA lined body                | 370/P110/2   |   |
| 11   | PTFE ball seal (2)            | 370/P115     | ☐ |
| 12   | Fortyt O ring (2)             | ORM0580400F0 | ☐ |
| 13   | PFA lined spindle/ball        | 370/P101     |   |
| 14   | M8 cap screw (4)              | 5111-010     |   |
| 15   | PFA lined clamp plate         | 370/P111     |   |
| 16   | Perfluoroelastomer O ring (2) | 5005-370P    | ☐ |
| 17   | M6 cap screw (2)              | 5111-015     |   |

## Seal Kit

| Description                          | Part No.   |
|--------------------------------------|------------|
| All parts marked ☐ in the Parts List | 370/P100SK |