



82.5mm Flanged Extended Hyper Maxi Pressure Only Relief Valve - Flange drilled 4 slots with a 145.0/152.4mm min/max PCD. (See below for drilling details) Suitable for a set pressure range of 75 to 204 PSI (5.17 to 14.07 Bar). Contact parts manufactured in 316 stainless steel. Fitted with Forty seals as standard.

Options - pressure/vacuum version. Standard body version for pressure below 75 PSI. Alternative seal materials are available.

Fort Vale offers a full range of threaded and flanged relief valves.

Specification

Weight 8.9 Kg *Note

Note : Weight and all other design conditions vary according to valve specification.

Design Approval by Lloyds Register of Shipping.

Valve Flow Data

Please contact sales@fortvale.com and request document reference 043/049/82/5/FLOW/NORM. See below for de-rations. Test certificates supplied as standard.

De-rations

Description	De-ration
Valve with removable gauze (176/2920)	-5.01%
Valve with 80mm Icon CDC burst disc (864/XXXX)	-15.00%
Valve with removable gauze (176/2920) and 80mm Icon CDC burst disc (864/XXXX)	-15.61%

Drilling Details & Fittings

Specification	PCD	Weld-in Flange	Gasket
DIN65 PN10	145.0mm	176/3250	5005-332
3" Table D	146.1mm	176/3140	5005-013
DIN80 PN6	150.0mm	176/3158	5005-334
3" ASA 150	152.4mm	176/3125	5005-204

Associated Parts

Part No.	Associated Parts
921/20BBSP	0-290 PSI pressure gauge, bottom entry, brass internal parts, 1/4" BSP connection
176/2920	Removable clamped gauze
864/XXXX	80mm bursting disc
311/3700	Stud kit (4 x M16)
311/3785	Bolt kit (cap screws) - 145/146mm PCD

Range

Part No.	Description
043/XXX0082S	82.5mm standard pressure only
043/XXXXX82S	82.5mm standard pressure/vacuum
049/XXXX0082S	82.5mm extended pressure only
049/XXXXXX82S	82.5mm extended pressure/vacuum

Fitting Details

Part Number : 049/XXXX0082S

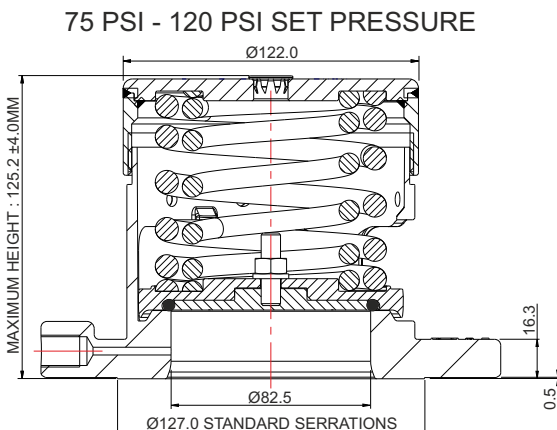

ABOVE 120 PSI SET PRESSURE

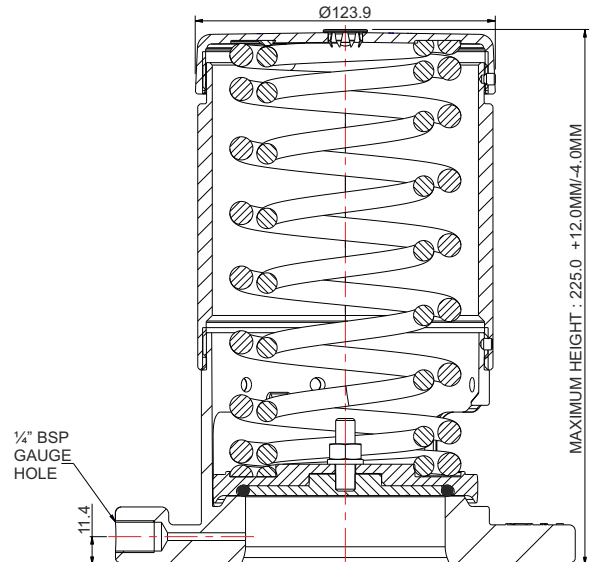

Parts drawing

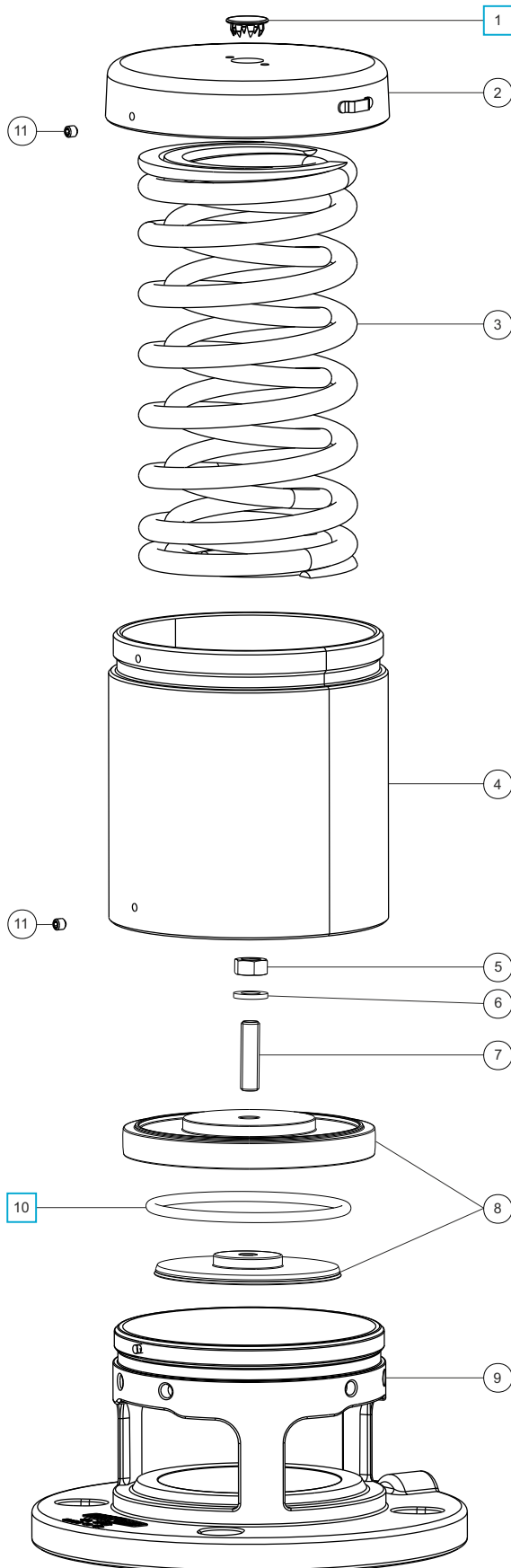

Item	Description	Part No.
1	Stainless steel plug	10978 <input type="checkbox"/>
2	Top cap *See Note 1	1860/XXXXXX
3	Spring *See Note 1	6104-XXXX
4	Extension tube *See Note 2	1860/1025/X
5	Full nut	5112-001
6	Spring washer	5113-003
7	Stud	11426
8	Pressure plate assy. *See Note 1	1860/X031XX
9	Body	1860/19SL
10	Fortyt O ring *See Note 1	ORB337F0 <input type="checkbox"/>
11	Grubscrew (2)	5121-001

NOTE 1 : Part number varies according to specification.

NOTE 2 : An extension tube is fitted to valves with a set pressure over 120 PSI (8.28 Bar). The part number varies according to the length of tube required.

SEAL KIT

Part number **043/1PSK** contains all parts marked

Visual inspection and service (where necessary) is recommended on a 6 monthly basis.