



SUPER MAXI RELIEF VALVE CATALOGUE

//

REVISION_16.01.17



The Fort Vale
Range of
Super Maxi &
Hyper Maxi
Relief Valves

PAGE

2½" BSP SUPER MAXI //

- » Pressure Only 1/2
- » Pressure/Vacuum 3/4
- » Pressure/Vacuum with Manual Vent Button 5/6
- » Pressure Only Extended Body 7/8
- » Pressure/Vacuum Extended Body 9/10

65MM FLANGED SUPER MAXI //

- » Pressure Only 11/12
- » Pressure/Vacuum 13/14
- » Pressure Only Extended Body 15/16

65-80MM TAPERED BORE FLANGED SUPER MAXI //

- » Pressure Only 17/18
- » Pressure/Vacuum 19/20
- » Pressure Only Extended Body 21/22

82.5MM FLANGED HYPER MAXI //

- » Pressure Only 23/24
- » Pressure/Vacuum 25/26
- » Pressure Only Extended Body 27/28
- » Pressure/Vacuum Extended Body 29/30

RELIEF VALVES FOR HYGIENIC SERVICE //

- » 65mm NB with 80mm DIN11851 connection 31/32
- » 2½" BSP - Food grade, for liquid flow 33/34
- » 65mm NB with 100mm DIN11851 connection - Food grade, for liquid flow 35/36

RELIEF VALVE ANCILLARIES //

- » Ancillaries 37/38
- » Weld-in Flanges 39/40
- » Fitting Details 41
- » Pressure & Vacuum Test Rig and Tool Kits 42





2½" BSP Super Maxi Emergency Relief Valve - 2½" BSP male connection with 65mm nominal bore. Suitable for a pressure range of between 2 - 75 PSI (0.14 - 5.17 Bar). Contact parts manufactured in 316 stainless steel fitted with Fortyt seals as standard. Complete with rubber/PTFE tank seal.

Options - combined pressure/vacuum version. Flanged connections available. High pressure range of extended body valves. A range of alternative seal materials is available.

Specification

Weight 4.12 Kg *Varies
Temperature Range Dependant upon seal material

Design Approval by Lloyds Register of Shipping.

Tests may be witnessed and valves individually stamped by an independent inspectorate by arrangement.

Test certificates are supplied as standard.

Valve flow rates are available by request.

*** Fitting ancillary items in the flow stream will alter the valve flow rate.**

Range

Part No.	Common Valve Configurations
010/13200	31.8 PSI (2.19 Bar)
010/14800	48.0 PSI (3.31 Bar)
010/15400	53.8 PSI (3.71 Bar)
010/16300	63.8 PSI (4.40 Bar)

NB Above part number varies according to valve pressure and vacuum settings. These are standard settings.

Associated Parts

Part No.	Associated Parts
600/1000	2½" BSP weld-in socket
176/7020	Adaptor assembly for bursting disc
176/3150	Tank weld-in pad
176/7001	Adaptor flange for bursting disc
862/XXXX *	65mm bursting disc – full range available
5005-398	CNAF/PTFE gasket to suit weld-in pad /adaptor flange
921/07BBSP	0-100 PSI pressure gauge, bottom entry, brass internal parts
921/07RBSP	0-100 PSI pressure gauge, rear entry, brass internal parts
920/07BBSP	0-100 PSI pressure gauge, bottom entry, stainless steel internal parts
176/2900 *	Removable flameproof gauze
176/6000 *	Gauzed cowl

Fitting Details

Example shown : 010/1XX00

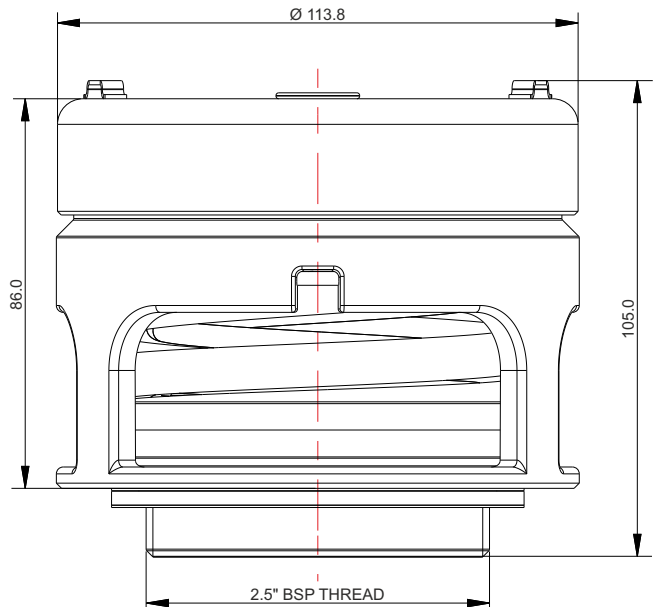
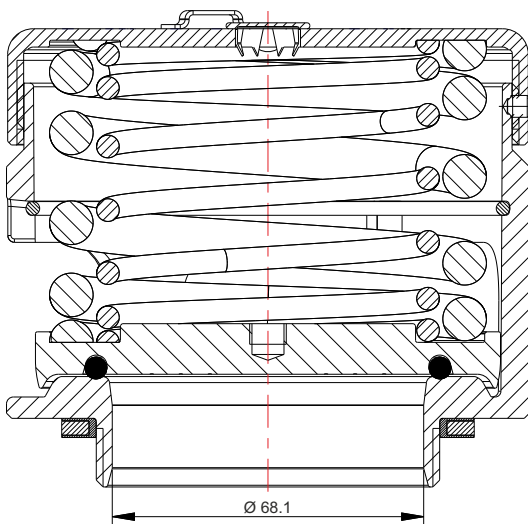

Parts Drawing

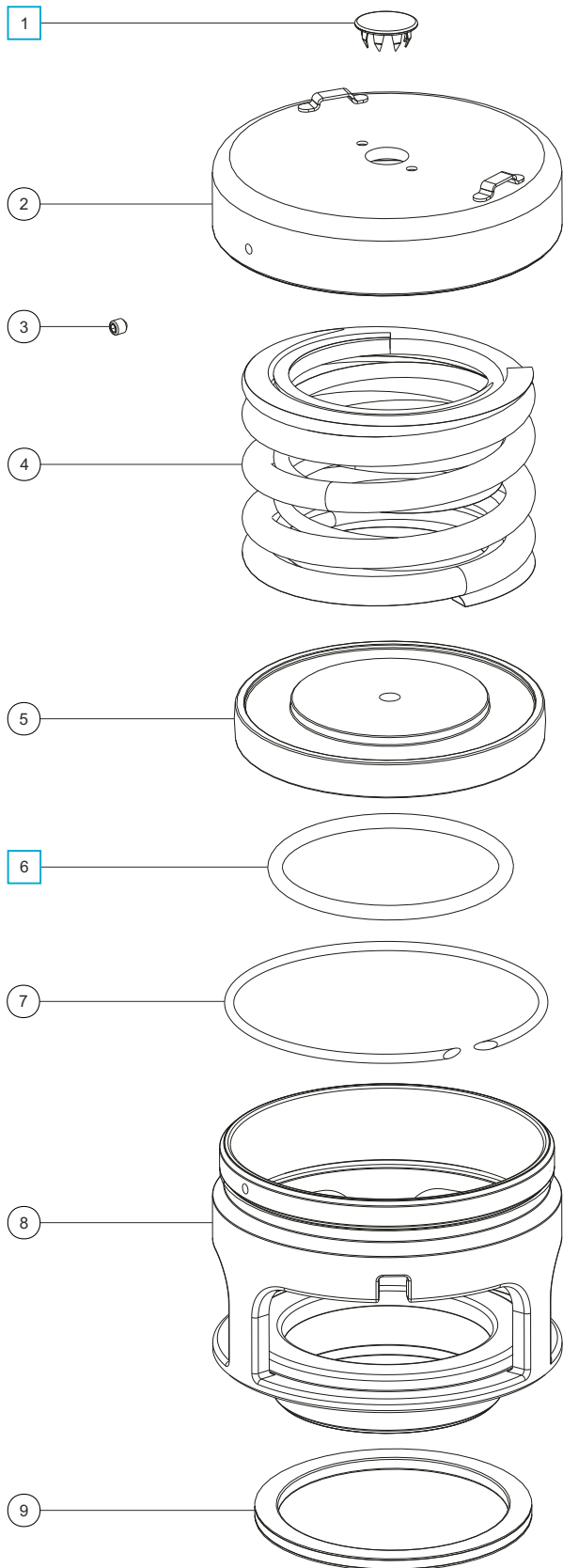

Item	Description	Part No.
1	Stainless steel plug	10978 <input type="checkbox"/>
2	Cap *See Note	1760/0005XX
3	Setting locking grub screw	5121-001
4	Pressure spring *See Table 1	6104-XXXX
5	Fortyt pressure plate *See Note	1860/005XXX
6	Fortyt pressure O ring	5005-101 <input type="checkbox"/>
7	Retaining ring clip	5120-067
8	Body assembly	1860/0100
9	Rubber/PTFE envelope seal	5005-046

NOTE : Part number varies according to specification.

SEAL KIT

Part number **000/1PSK** contains all parts marked

TABLE 1

Common Pressure Settings	Pressure Springs Part No.
31.8 PSI (2.19 Bar)	6104-0252
48.0 PSI (3.31 Bar)	6104-0112 & 6104-0252
53.8 PSI (3.71 Bar)	6104-0422 (Pair)
63.8 PSI (4.40 Bar)	6104-0485 (Pair)

Pressure springs are available from 2 PSI (0.14 Bar) up to 75 PSI (5.17 Bar)

Visual inspection and service (where necessary) is recommended regularly. A detailed step-by-step repair manual is available for our Super Maxi Relief Valves. Please contact our Sales team for further information.



2½" BSP Super Maxi Emergency Relief Valve - 2½" BSP male connection with 65mm nominal bore. Suitable for a pressure range of between 2 - 75 PSI (0.14 - 5.17 Bar) and a vacuum range of between 0 - 26"Hg (0 - 0.88 Bar). Contact parts manufactured in 316 stainless steel. Fitted with Fortyt seals as standard. Complete with rubber/PTFE tank seal.

Options - pressure only version. Flanged connections available. Range of high pressure extended body valves. Manual vent button option. A range of alternative seal materials is available.

Specification

Weight 4.08 Kg *Varies
 Temperature Range Dependant upon seal material

Design Approval by Lloyds Register of Shipping.

Tests may be witnessed and valves individually stamped by an independent inspectorate by arrangement.

Test certificates are supplied as standard.

Valve flow rates are available by request.

*** Fitting ancillary items in the flow stream will alter the valve flow rate.**

Range

Part No.	Common Valve Configurations
010/13212	31.8 PSI (2.19 Bar) & 6.2"Hg (-0.21 Bar)
010/14812	48.0 PSI (3.31 Bar) & 6.2"Hg (-0.21 Bar)
010/15412	53.8 PSI (3.71 Bar) & 6.2"Hg (-0.21 Bar)
010/16312	63.8 PSI (4.40 Bar) & 6.2"Hg (-0.21 Bar)

NB Above part number varies according to valve pressure and vacuum settings. These are standard settings.

Associated Parts

Part No.	Associated Parts
600/1000	2½" BSP weld-in socket
176/3150	Tank weld-in pad
5005-398	CNAF/PTFE gasket to suit weld-in pad/adaptor flange
921/07BBSP	0-100 PSI pressure gauge, bottom entry, brass internal parts
921/07RBSP	0-100 PSI pressure gauge, rear entry, brass internal parts
920/07BBSP	0-100 PSI pressure gauge, bottom entry, stainless steel internal parts
176/2900 *	Removable flameproof gauze
176/6000 *	Gauzed cowl

Fitting Details

Example shown : 010/1XXXX

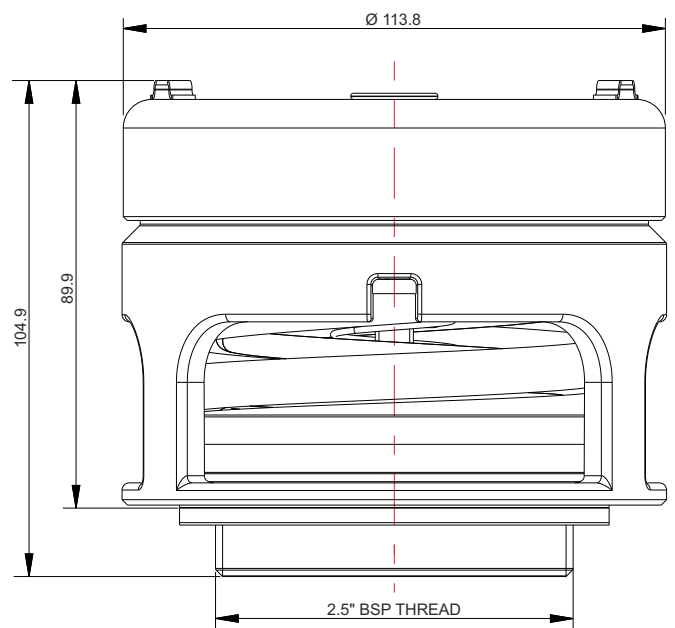
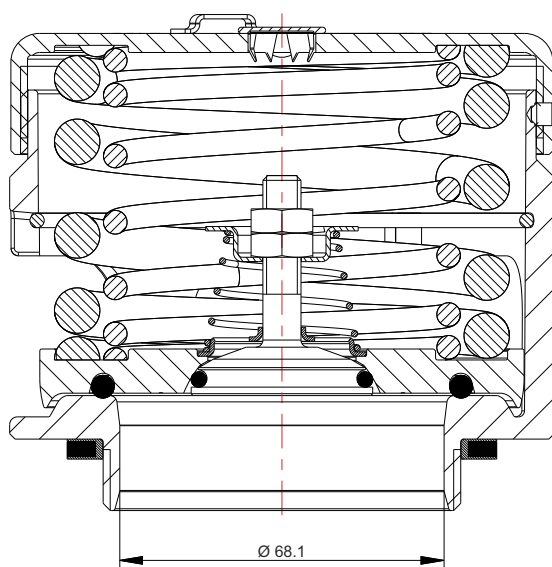

Parts drawing

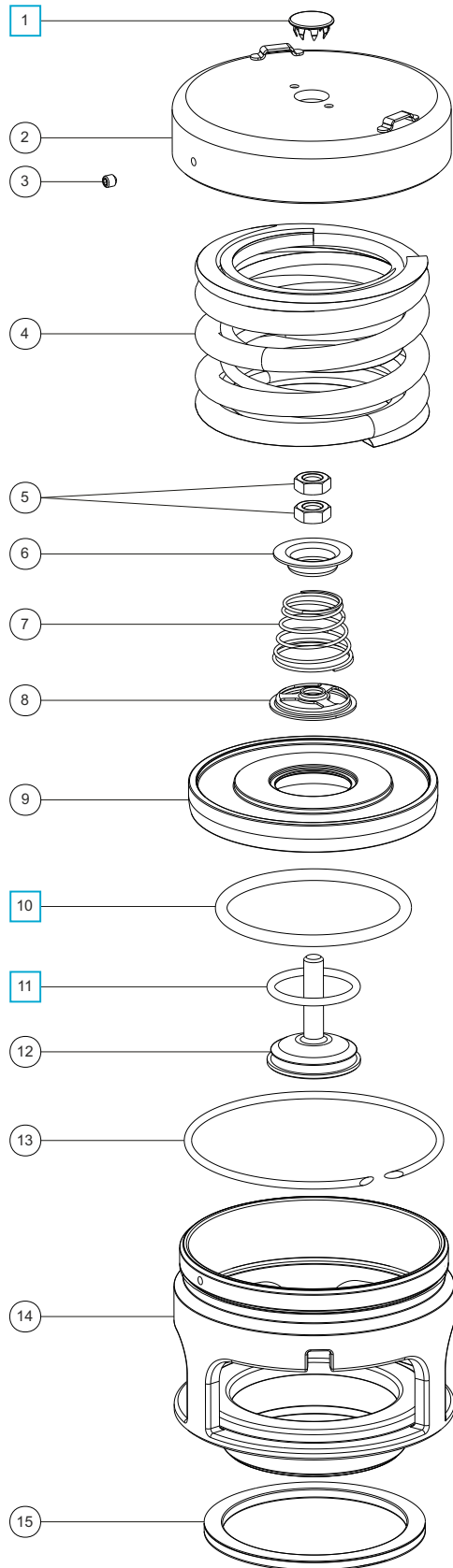

Item	Description	Part No.
1	Stainless steel plug	10978 <input type="checkbox"/>
2	Cap *See Note	1760/0005XX
3	Setting locking grub screw	5121-001
4	Pressure springs *See Table 1	6104-XXXX
5	M8 half nut (2)	5112-004
6	Vacuum spring pad	1860/0005
7	Vacuum spring *See Table 2	7104-XXX
8	Spring pad	10986/3
9	Pressure plate *See Note	1860/005XXX
10	Fortyt pressure O ring	5005-101 <input type="checkbox"/>
11	Fortyt vacuum O ring	5005-108H <input type="checkbox"/>
12	Vacuum poppet	10983V/3
13	Retaining ring clip	5120-067
14	Body	1860/0100
15	Rubber/PTFE envelope seal	5005-046

NOTE : Part number varies according to specification.

SEAL KIT

Part number 000/1PVSK contains all parts marked

TABLE 1

Common Pressure Settings	Pressure Spring Part No.
31.8 PSI (2.19 Bar)	6104-0252
48.0 PSI (3.31 Bar)	6104-0112 & 6104-0252
53.8 PSI (3.71 Bar)	6104-0422 (Pair)
63.8 PSI (4.40 Bar)	6104-0485 (Pair)

Pressure springs are available from 2 PSI (0.14 Bar) up to 75 PSI (5.17 Bar)

TABLE 2

Common Vacuum Setting	Vacuum Spring Part No.
6.2"Hg (0.21 Bar)	7104-012

Vacuum springs are available from 0.5"Hg (0.02 Bar) to 26"Hg (0.88 Bar)

Visual inspection and service (where necessary) is recommended regularly. A detailed step-by-step repair manual is available for our Super Maxi Relief Valves. Please contact our Sales team for further information.



2½" BSP Super Maxi Relief Valve with Manual Vent Button - 2½" BSP male connection with 65mm nominal bore. Suitable for a pressure range of between 2 - 75 PSI (0.14 - 5.17 Bar) and a vacuum range of between 0 - 24"Hg (0 - 0.81 Bar). Contact parts manufactured in 316 stainless steel. Fitted with Fortyt seals as standard. Complete with rubber/PTFE tank seal.

Options - Alternative seal materials are available. Cable vacuum actuator linkage available to clamp to vent button for remote operation.

Specification

Weight 2.98 Kg *Varies
 Temperature Range Dependant upon seal material

Design Approval by Lloyds Register of Shipping.

Tests may be witnessed and valves individually stamped by an independent inspectorate by arrangement.

Test certificates are supplied as standard.

Valve flow rates are available by request.

*** Fitting ancillary items in the flow stream will alter the valve flow rate.**

Range

Part No.	Pressure	Vacuum
01B/13212	31.8 PSI (2.19 Bar)	6.2" Hg (-0.21 Bar)
01B/14812	48.0 PSI (3.31 Bar)	6.2" Hg (-0.21 Bar)
01B/15412	53.8 PSI (3.71 Bar)	6.2" Hg (-0.21 Bar)
01B/16312	63.8 PSI (4.40 Bar)	6.2" Hg (-0.21 Bar)

NB Above part numbers vary according to valve pressure and vacuum settings. These are standard settings.

Associated Parts

Part No.	Description
600/1000	2½" BSP weld-in socket
176/3150	Tank weld-in pad
5005-398	CNAF/PTFE gasket to suit weld-in pad / adaptor flange
921/07BBSP	0-100 PSI pressure gauge, bottom entry, brass internal parts
921/07RBSP	0-100 PSI pressure gauge, rear entry, brass internal parts
920/07BBSP	0-100 PSI pressure gauge, bottom entry, stainless steel internal parts
176/2900 *	Removable clamped gauze
176/6000 *	Gauzed cowl
1860/0400	Cable vacuum actuator

Fitting Details

Example shown : 01B/1XXXX

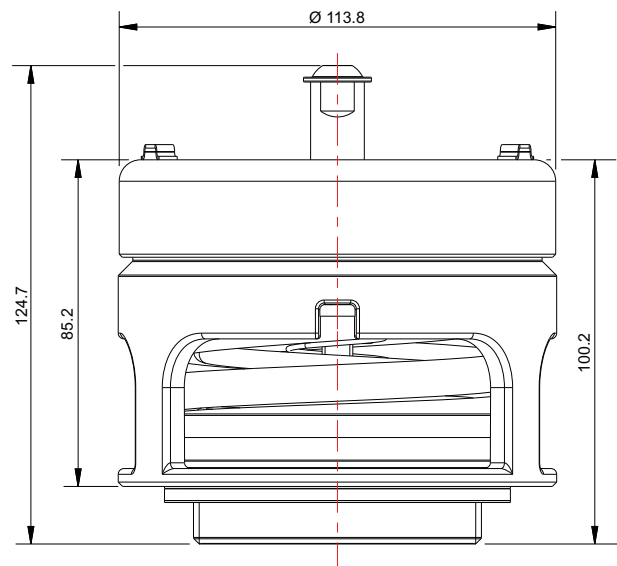
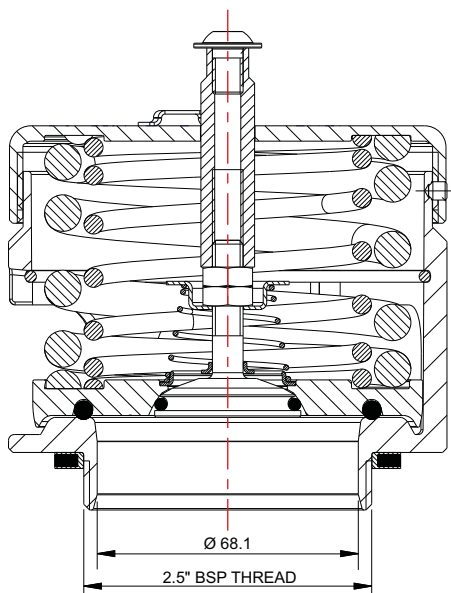

Parts drawing

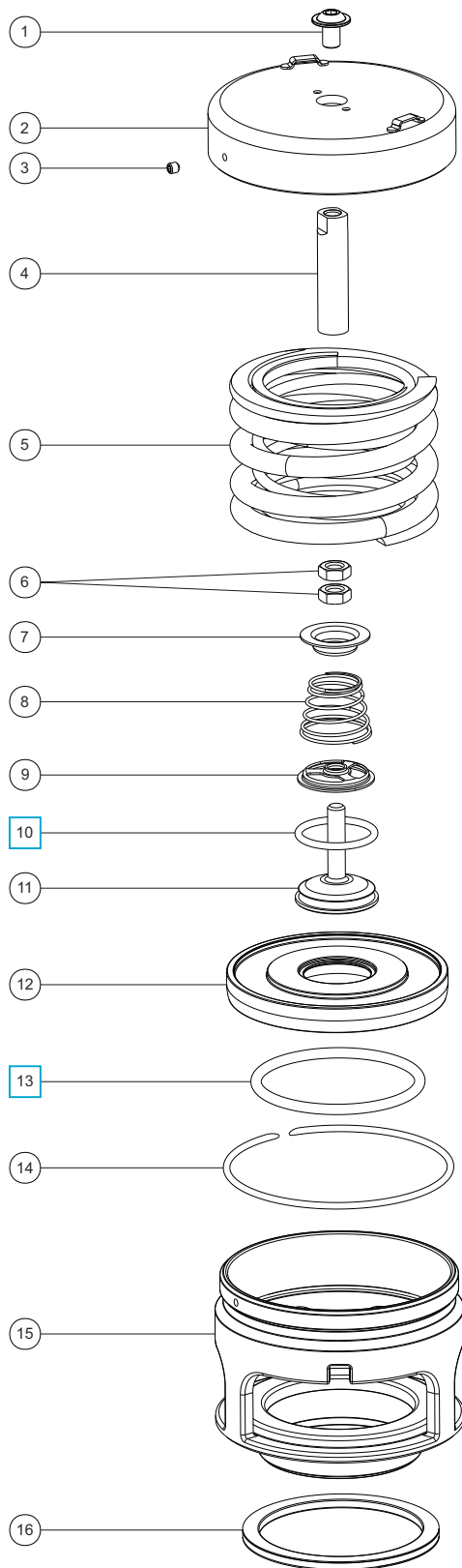

Item	Description	Part No.
1	Flanged button screw	5111-9812
2	Cap	1760/0005
3	Setting locking grub screw	5121-001
4	Stem extension	1860/0070
5	Pressure spring pair *See Table 1	6104-XXXX
6	M8 locknut (2)	5112-004
7	Vacuum spring pad	1860/0005
8	6" Vacuum spring	7104-012
9	Spring pad	10986/3
10	Fortyt vacuum O ring	5005-108H <input type="checkbox"/>
11	Vacuum poppet	10983V/3
12	Pressure plate *See Note	1860/005XXX
13	Fortyt pressure O ring	5005-101 <input type="checkbox"/>
14	Retaining ring clip	5120-067
15	Body assembly	1860/0100
16	Rubber/PTFE envelope seal	5005-046

NOTE : Part number varies according to specification.

SEAL KIT

Part number **000/1PVSK** contains all parts marked

TABLE 1

Common Pressure Settings	Pressure Springs Part No.
31.8 PSI (2.19 Bar)	6104-0252
48.0 PSI (3.31 Bar)	6104-0112 & 6104-0252
53.8 PSI (3.71 Bar)	6104-0422 (Pair)
63.8 PSI (4.40 Bar)	6104-0485 (Pair)

Visual inspection and service (where necessary) is recommended regularly. A detailed step-by-step repair manual is available for our Super Maxi Relief Valves. Please contact our Sales team for further information.



Extended body 65mm Super Maxi Relief Valve - 2½" BSP male connection with 65mm nominal bore. Suitable for a pressure range of between 66 - 204 PSI (4.55 - 14.07 Bar). Contact parts manufactured in 316 stainless steel. Fitted with Fortyt seals as standard. Complete with rubber/PTFE tank seal.

Options - combined pressure/vacuum version. Alternative seal materials are available.

Specification

Weight 4.97 Kg *Varies
 Temperature Range Dependant upon seal material

Design Approval by Lloyds Register of Shipping.

Tests may be witnessed and valves individually stamped by an independent inspectorate by arrangement.

Test certificates are supplied as standard.

Valve flow rates are available by request.

*** Fitting ancillary items in the flow stream will alter the valve flow rate.**

Range

Part No.	Description
018/1XXXXXX	Pressure/vacuum valve
018/1XXX00	Pressure only valve

NB Above part number varies according to valve pressure and vacuum settings.

Associated Parts

Part No.	Description
600/1000	2½" BSP weld-in socket
176/7020	Adaptor assembly for bursting disc
176/3150	Tank weld-in pad
176/7001	Adaptor flange for bursting disc
862/XXXX *	65mm bursting disc
5005-398	CNAF/PTFE gasket to suit weld-in pad/adaptor flange
921/20BBSP	0-290 PSI pressure gauge, bottom entry, brass internal parts, ¼" BSP connection
921/20BNPT	0-290 PSI pressure gauge, bottom entry, brass internal parts, ¼" NPT connection
176/2900 *	Removable clamped gauze
176/6000 *	Gauzed cowl

Fitting Details

Example shown : 018/1XXX00

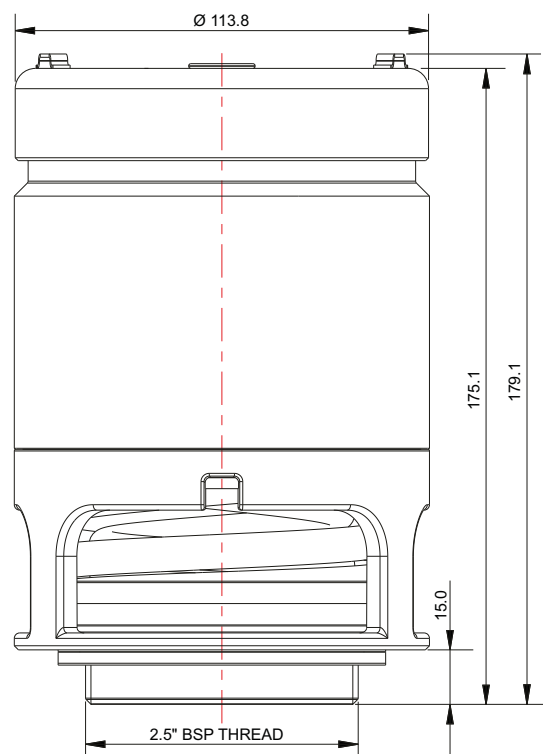
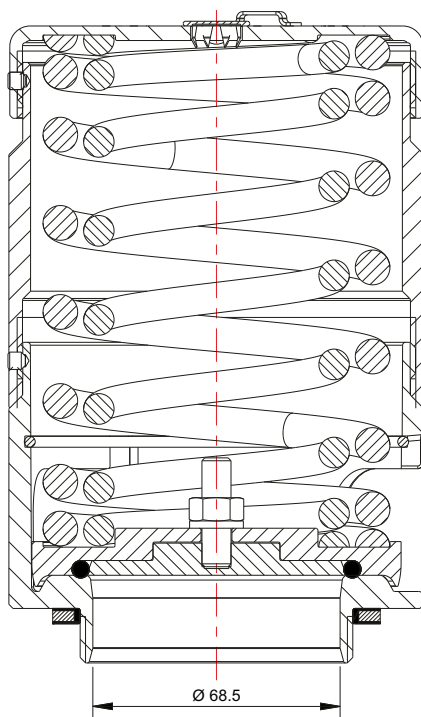

Parts drawing

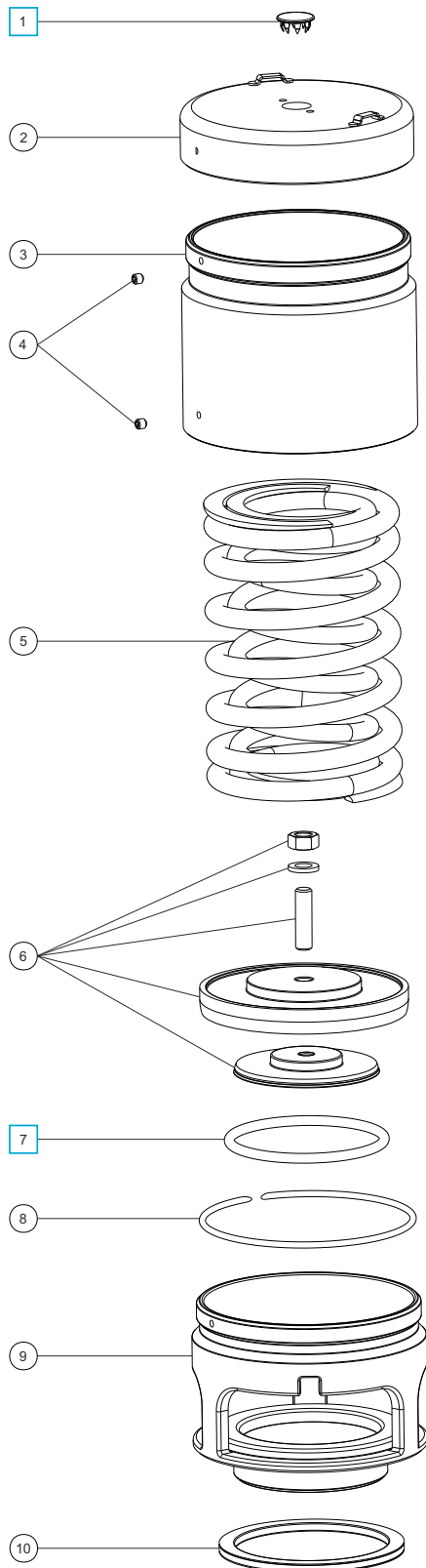

Item	Description	Part No.
1	Stainless steel plug	10978 <input type="checkbox"/>
2	Top cap *See Note	1760/0005XX
3	Extension tube	1860/0035
4	Setting locking grub screw (2)	5121-001
5	Pressure spring pair *See Table 1	6104-XXXX
6	Pressure plate *See Note	1860/X0XXXX
7	Pressure O ring *See Note	5005-XXX <input type="checkbox"/>
8	Retaining ring clip	5120-067
9	Body	1860/0100
10	Rubber/PTFE envelope seal	5005-046

NOTE: Part number varies according to specification.

SEAL KIT

Part number **018/XPSK** contains all parts marked 'X' in part number indicates variable seal material. Please contact Sales for correct seal kit part number.

TABLE 1

Common Pressure Settings	Pressure Spring Part No.
116 PSI (8.00 Bar)	6104-0696
145 PSI (10.00 Bar)	6104-1145
175 PSI (12.07 Bar)	6104-1375

Visual inspection and service (where necessary) is recommended regularly. A detailed step-by-step repair manual is available for our Super Maxi Relief Valves. Please contact our Sales team for further information.



Extended body 65mm Super Maxi Relief Valve - 2½" BSP male connection with 65mm nominal bore. Suitable for a pressure range of between 66 - 204 PSI (4.55 - 14.07 Bar) and a vacuum range of between 0 - 26"Hg (0 - 0.88 Bar). Contact parts manufactured in 316 stainless steel. Fitted with Fortyt seals as standard. Complete with rubber/PTFE tank seal.

Options - pressure only version. Alternative seal materials are available.

Specification

Weight 4.95 Kg *Varies
 Temperature Range Dependant upon seal material

Design Approval by Lloyds Register of Shipping.

Tests may be witnessed and valves individually stamped by an independent inspectorate by arrangement.

Test certificates are supplied as standard.

Valve flow rates are available by request.

*** Fitting ancillary items in the flow stream will alter the valve flow rate.**

Range

Part No.	Description
018/1XXXXX	Pressure/vacuum valve
018/1XXX00	Pressure only valve

NB Above part number varies according to valve pressure and vacuum settings.

Associated Parts

Part No.	Description
600/1000	2½" BSP weld-in socket
176/3150	Tank weld-in pad
5005-398	CNAF/PTFE gasket to suit weld-in pad/adaptor flange
921/20BBSP	0-290 PSI pressure gauge, bottom entry, brass internal parts, ¼" BSP connection
921/20BNPT	0-290 PSI pressure gauge, bottom entry, brass internal parts, ¼" NPT connection
176/2900 *	Removable clamped gauze
176/6000 *	Gauzed cowl

Fitting Details

Example shown : 018/1XXXXX

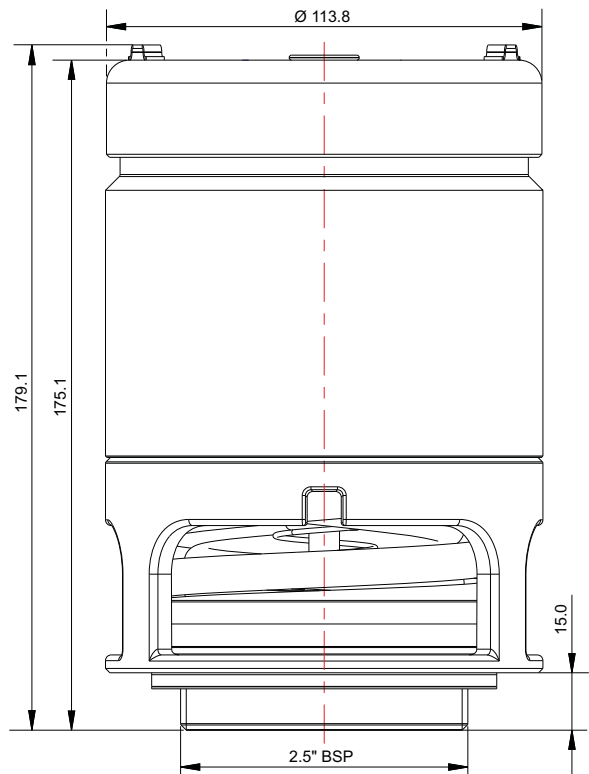
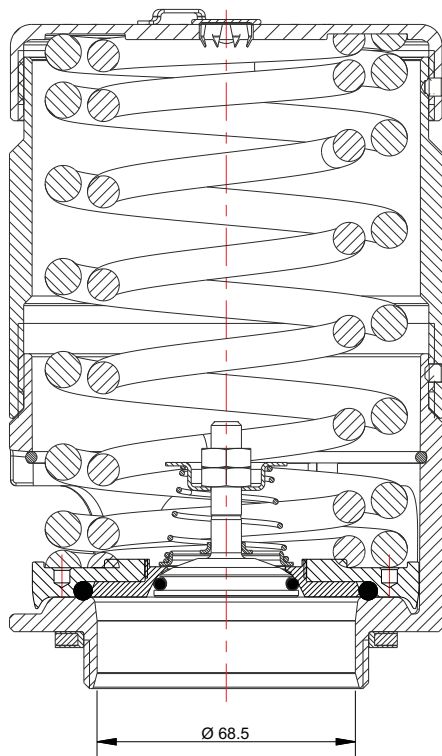

Parts drawing

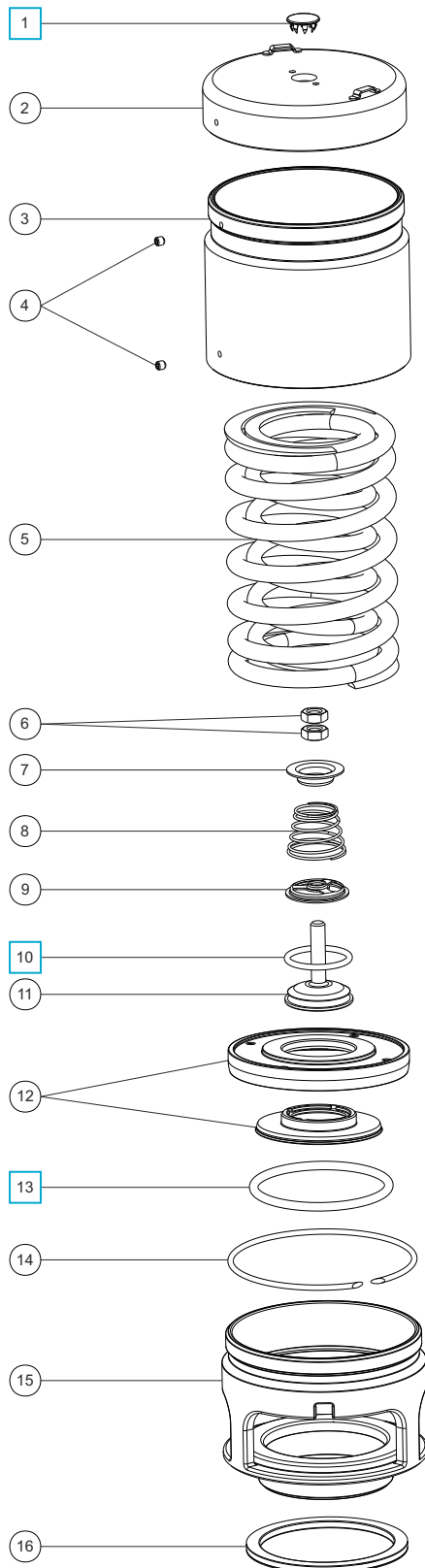

Item	Description	Part No.
1	Stainless steel plug	10978 <input type="checkbox"/>
2	Top cap *See Note	1760/0005XX
3	Extension tube	1860/0035
4	Setting locking grub screw (2)	5121-001
5	Pressure spring pair *See Table 1	6104-XXXX
6	M8 lock nut (2)	5112-004
7	Vacuum spring pad	1860/0005
8	Vacuum spring *See Table 2	7104-XXX
9	Spring pad	10986/3
10	PTFE vacuum O ring	5005-108H <input type="checkbox"/>
11	Vacuum poppet	10983V/3
12	Pressure plate *See Note	1860/X0XXXX
13	Pressure O ring *See Note	5005-XXX <input type="checkbox"/>
14	Retaining ring clip	5120-067
15	Body	1860/0100
16	Rubber/PTFE envelope seal	5005-046

NOTE: Part number varies according to specification.

SEAL KIT

Part number **018/XPSK** contains all parts marked 'X' in part number indicates variable seal material. Please contact Sales for correct seal kit part number.

TABLE 1

Common Pressure Settings	Pressure Spring Part No.
95 PSI (6.55 Bar)	6104-0763
96 PSI (6.62 Bar)	6104-0763
110 PSI (7.58 Bar)	6104-0870

TABLE 2

Common Vacuum Settings	Vacuum Spring Part No.
6" Hg (-0.20 Bar)	7104-012
12" Hg (-0.41 Bar)	7104-024

Visual inspection and service (where necessary) is recommended regularly. A detailed step-by-step repair manual is available for our Super Maxi Relief Valves. Please contact our Sales team for further information.



Flanged 65mm Super Maxi Emergency Relief Valve - flanged tank connection *See below for flange options. Suitable for a pressure range of between 2 - 70 PSI (0.14 - 4.83 Bar). Contact parts manufactured in 316 stainless steel. Fitted with Fortyt seals as standard.

Options - combined pressure/vacuum version. 80mm nominal bore range. BSP threaded range. High pressure extended body valves. Tapered Bore version. Lined version for corrosive cargoes. Alternative seal materials are available. Additional flange drillings are available.

Specification

Weight 7.13 Kg *Varies
 Temperature Range Dependant upon seal material

Design Approval by Lloyds Register of Shipping.

Tests may be witnessed and valves individually stamped by an independent inspectorate by arrangement.

Test certificates are supplied as standard.

Valve flow rates are available by request.

*** Fitting ancillary items in the flow stream will alter the valve flow rate.**

Range

Part No.	Description
013/1XX0065X	65mm NB flanged Super Maxi valve

NB Above part number varies according to valve pressure and vacuum settings.

Associated Parts

Part No.	Description
921/07BBSP	0-100 PSI pressure gauge, bottom entry, brass internal parts
921/07RBSP	0-100 PSI pressure gauge, rear entry, brass internal parts
920/07BBSP	0-100 PSI pressure gauge, bottom entry, stainless steel internal parts
176/2900 *	Removable clamped gauze
862/XXXX *	65mm bursting disc
311/3700	Stud kit (4 x M16)

Fitting Details

Example shown : 013/1XX0065X

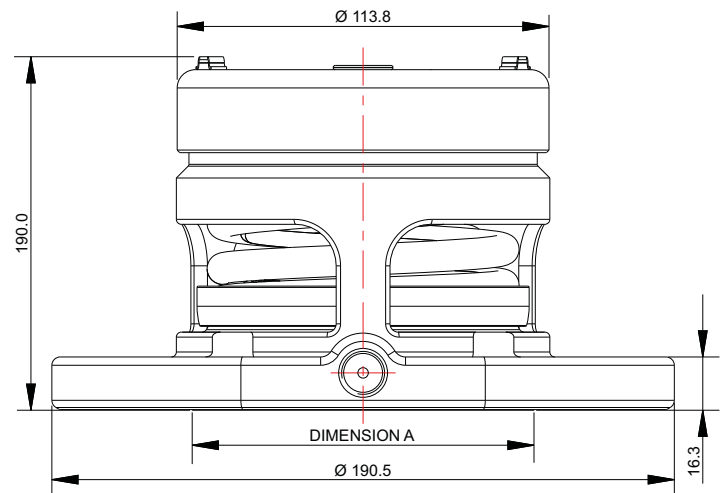
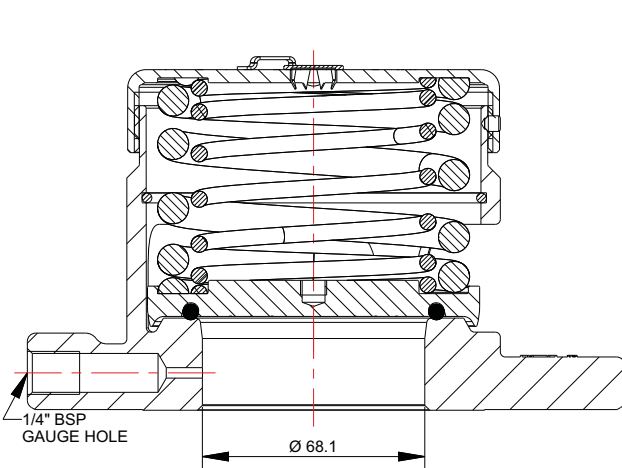

Part Number	Dimension A	Flange Drilling Pattern			Flange Spec.	Tank Weld in Pad	Gasket
		No. of Holes	Ø (mm) (equi-spaced)	PCD (mm)			
013/1XX0065SL	Ø 125.5	4	18	145.0	DIN 65 PN10	176/3245	5005-892
	Ø 127.0			150.0	DIN 80 PN6		
	Ø 109.2			146.1	3" BSTD		
	Ø 127.0			152.4	3" ASA 150		
013/1XX00654	Ø 104.6	4	18	139.7	2.5" ASA 150	176/3035	5005-897

Parts Drawing

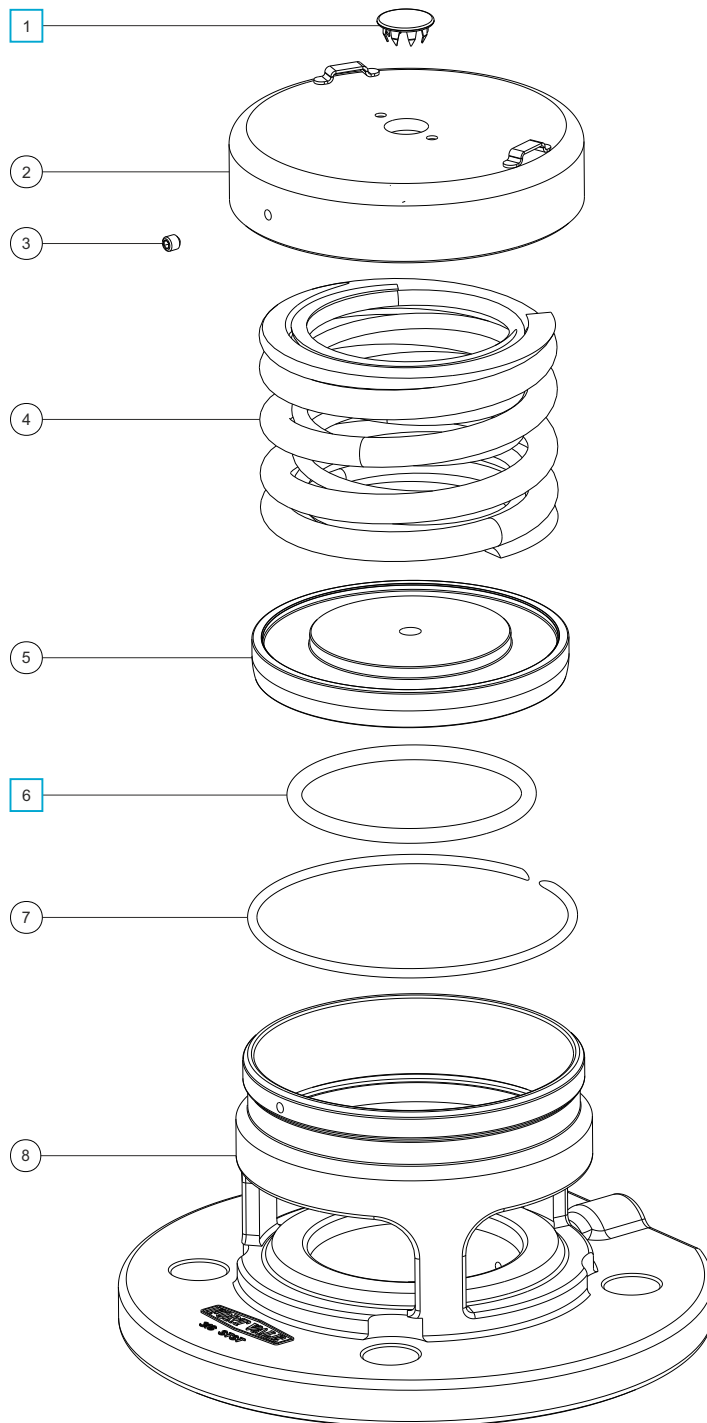

Item	Description	Part No.
1	Stainless steel plug	10978 <input type="checkbox"/>
2	Cap *See Note	1760/0005XX
3	Setting locking grub screw	5121-001
4	Pressure spring pair *See Table 1	6104-XXXX
5	Fortyt pressure plate *See Note	1860/005XXX
6	Fortyt pressure O ring	5005-101 <input type="checkbox"/>
7	Retaining ring clip	5120-067
8	Body *See Table 2	1860/065X

NOTE : Part number varies according to specification.

SEAL KIT

Part number **000/1PSK** contains all parts marked

TABLE 1

Common Pressure Settings	Pressure Spring Part No.
31.8 PSI (2.19 Bar)	6104-0252
48.0 PSI (3.31 Bar)	6104-0112 & 6104-0252
53.8 PSI (3.71 Bar)	6104-0422 (Pair)
63.8 PSI (4.40 Bar)	6104-0485 (Pair)

TABLE 2

Part No.	Drilling	Body
013/1XX00650	DIN65 PN10	1860/0650
013/1XX00651	DIN80 PN6	1860/0651
013/1XX00653	3" BSTD	1860/0653
013/1XX00654	2½" ASA150	1860/0654
013/1XX00655	3" ASA150	1860/0655
013/1XX00657	DIN80 PN10	1860/0657

Visual inspection and service (where necessary) is recommended regularly. A detailed step-by-step repair manual is available for our Super Maxi Relief Valves. Please contact our Sales team for further information.



Flanged 65mm Super Maxi Emergency Relief Valve - flanged tank connection with 65mm nominal bore (see below for flange options). Suitable for a pressure range of between 2 - 70 PSI (0.14 - 4.83 Bar) and a vacuum setting of between 0 -24"Hg (0 - 0.81 Bar). Contact parts manufactured in 316 stainless steel. Fitted with Fortyt seals as standard.

Options - pressure only version. 80mm nominal bore range. BSP range. High pressure extended body valves. Tapered Bore version. Alternative seal materials are available. Additional flange drillings are available.

Specification

Weight 5.93 Kg *Varies
 Temperature Range Dependant upon seal material

Design Approval by Lloyds Register of Shipping.

Tests may be witnessed and valves individually stamped by an independent inspectorate by arrangement.

Test certificates are supplied as standard.

Valve flow rates are available by request.

*** Fitting ancillary items in the flow stream will alter the valve flow rate.**

Range

Part No.	Description
013/1XXXX65X	65mm NB flanged Super Maxi valve

NB Above part number varies according to valve pressure and vacuum settings.

Associated Parts

Part No.	Description
921/07BBSP	0-100 PSI pressure gauge, bottom entry, brass internal parts
921/07RBSP	0-100 PSI pressure gauge, rear entry, brass internal parts
920/07BBSP	0-100 PSI pressure gauge, bottom entry, stainless steel internal parts
176/2900 *	Removable clamped gauge
311/3700	Stud kit (4 x M16)

Fitting Details

Example shown : 013/1XXXX65X

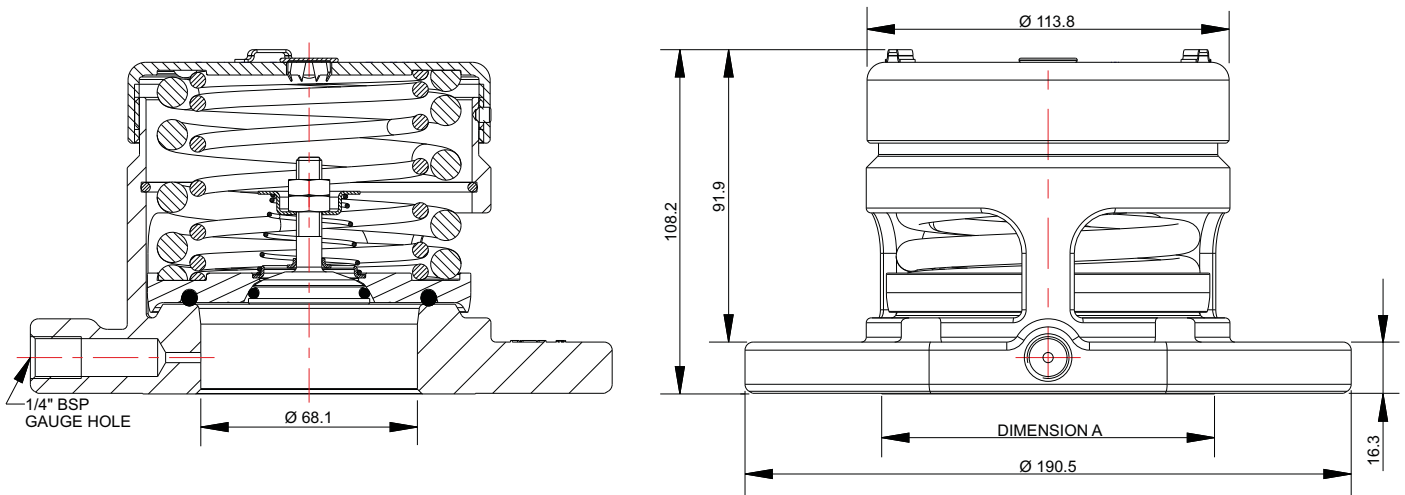

Part Number	Dimension A	Flange Drilling Pattern			Flange Spec.	Tank Weld in Pad	Gasket
		No. of Holes	Ø (mm) (equi-spaced)	PCD (mm)			
013/1XXXX65SL	Ø 125.5	4	18	145.0	DIN 65 PN10	176/3245	5005-892
	Ø 109.2			146.1	3" BSTD		
	Ø 127.0			152.4	3" ASA 150		
013/1XXXX654	Ø 104.6	4	18	139.7	2.5" ASA 150	176/3035	5005-897

Parts Drawing

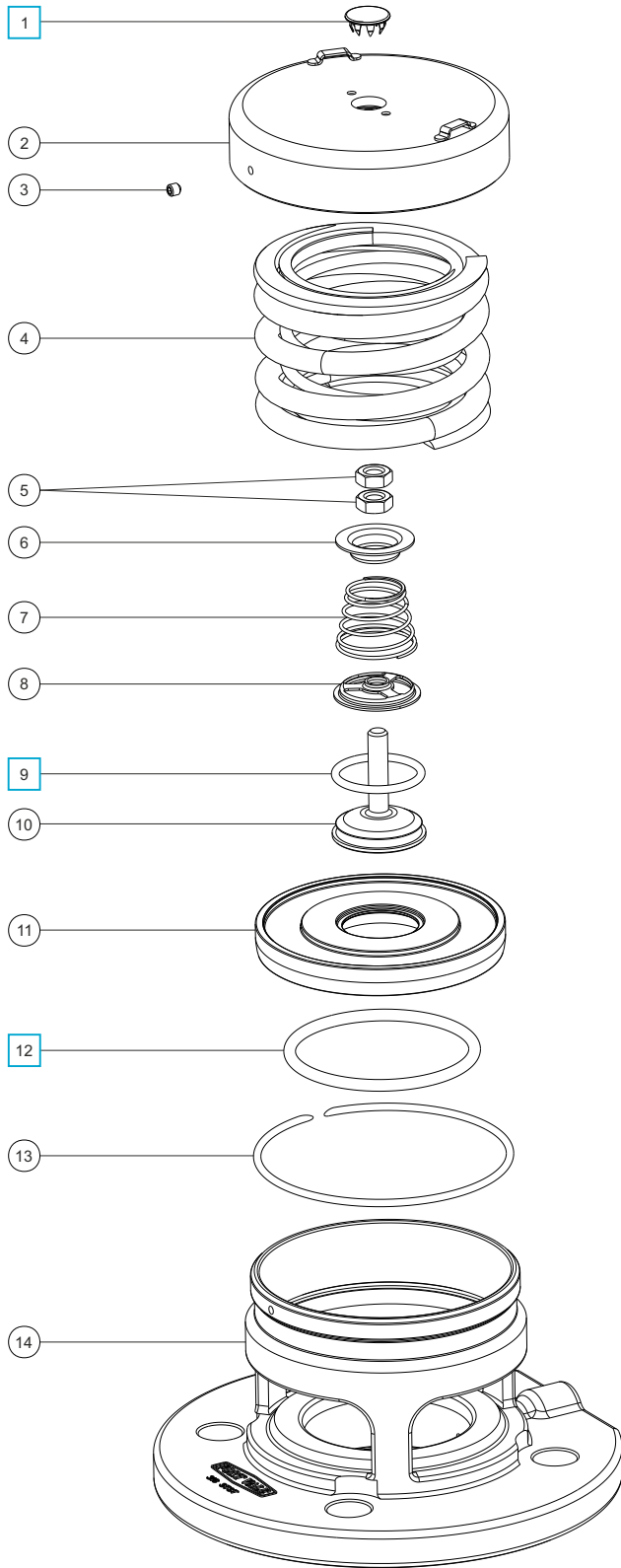

Item	Description	Part No.
1	Stainless steel plug	10978 <input type="checkbox"/>
2	Cap	1760/0005
3	Setting locking grub screw	5121-001
4	Pressure spring pair *See Table 1	6104-XXXX
5	M8 nut (2)	5112-004
6	Vacuum spring pad	1860/0005
7	Vacuum spring *See Table 2	7104-XXX
8	Spring pad	10986/3
9	Fortyt vacuum O ring	5005-108H <input type="checkbox"/>
10	Vacuum poppet	10983V/3
11	Pressure plate *See Note	1860/005XXX
12	Fortyt pressure O ring	5005-101 <input type="checkbox"/>
13	Retaining ring clip	5120-067
14	Body *See Table 3	1860/065X

NOTE : Part number varies according to specification.

SEAL KIT

Part number **000/1PVSK** contains all parts marked

TABLE 1

Common Pressure Settings	Pressure Springs Part No.
31.8 PSI (2.19 Bar)	6104-0252
48.0 PSI (3.31 Bar)	6104-0112 & 6104-0252
53.8 PSI (3.71 Bar)	6104-0422 (Pair)
63.8 PSI (4.40 Bar)	6104-0485 (Pair)

TABLE 2

Common Vacuum Settings	Vacuum Spring Part No.
3"Hg (-0.10 Bar)	7104-006
6"Hg (-0.20 Bar)	7104-012

TABLE 3

Part No.	Drilling	Body
013/1XX00650	DIN65 PN10	1860/0650
013/1XX00653	3" BSTD	1860/0653
013/1XX00654	2½" ASA150	1860/0654
013/1XX00655	3" ASA150	1860/0655
013/1XX00657	DIN80 PN10	1860/0657

Visual inspection and service (where necessary) is recommended regularly. A detailed step-by-step repair manual is available for our Super Maxi Relief Valves. Please contact our Sales team for further information.



Extended body flanged 65mm Super Maxi Relief Valve - flanged tank connection with 65mm nominal bore (see below for flange options). Suitable for a pressure range of between 66 - 204 PSI (4.55 - 14.07 Bar). Contact parts manufactured in 316 stainless steel. Fitted with Forty seals as standard.

Options - combined pressure/vacuum version available by request only. 80mm nominal bore range. Tapered bore version. Alternative seal materials are available. Additional flange drillings are available.

Specification

Weight 7.97 Kg *Varies
 Temperature Range Dependant upon seal material

Design Approval by Lloyds Register of Shipping.

Tests may be witnessed and valves individually stamped by an independent inspectorate by arrangement.

Test certificates are supplied as standard.

Valve flow rates are available by request.

*** Fitting ancillary items in the flow stream will alter the valve flow rate.**

Range

Part No.	Description
019/1XXX065X	65mm NB flanged extended body Super Maxi valve

NB Above part number varies according to valve pressure and vacuum settings.

Associated Parts

Part No.	Description
921/20BBSP	0-290 PSI pressure gauge, bottom entry, brass internal parts
920/20BBSP	0-290 PSI pressure gauge, bottom entry, stainless steel internal parts
176/2900 *	Removable clamped gauge
862/XXXX *	65mm bursting disc
311/3700	Stud kit (4 x M16)

Fitting Details

Example shown : 019/1XXX065X

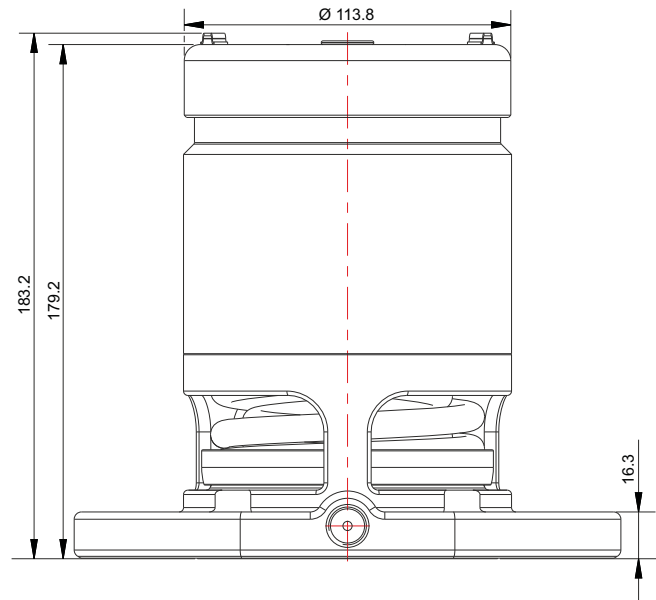
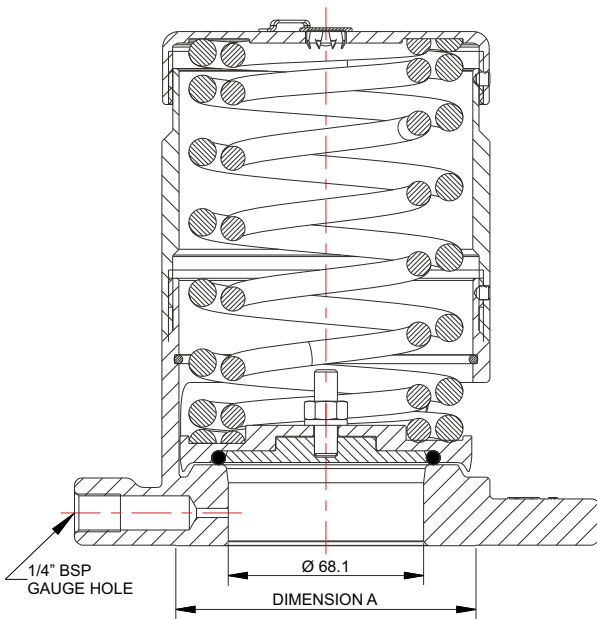

Part Number	Dimension A	Flange Drilling Pattern			Flange Spec.	Tank Weld in Pad	Gasket
		No. of Holes	Ø (mm) (equi-spaced)	PCD (mm)			
019/1XXX065SL	Ø 125.5	4	18	145.0	DIN 65 PN10	176/3245	5005-892
	Ø 127.0			150.0	DIN 80 PN6		
	Ø 109.2			146.1	3" BSTD		
	Ø 127.0			152.4	3" ASA 150		
019/1XXX0654	Ø 104.6	4	18	139.7	2.5" ASA 150	176/3035	5005-897

Parts drawing

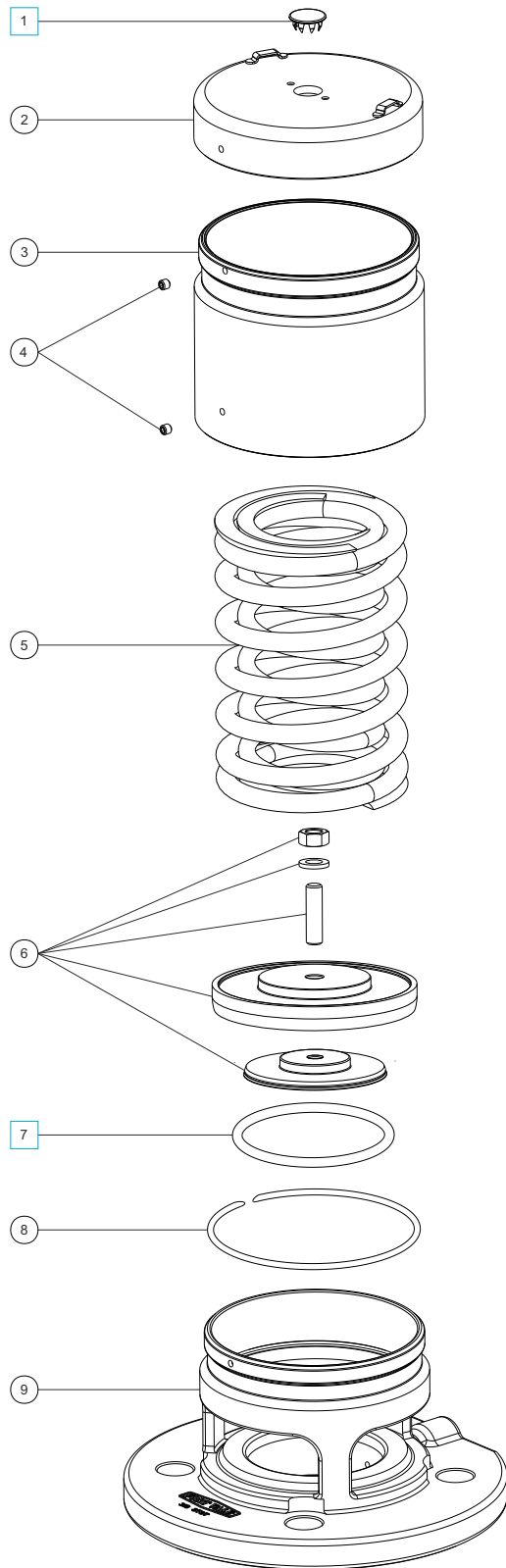

Item	Description	Part No.
1	Stainless steel plug	10978
2	Top cap *See Note	1760/0005XX
3	Extension tube	1860/0035
4	Setting locking grub screw (2)	5121-001
5	Pressure spring pair *See Table 1	6104-XXXX
6	Pressure plate *See Note	1860/X0X8XX
7	Pressure O ring *See Note	5005-XXX
8	Retaining ring clip	5120-067
9	Body *See Table 2	1860/065X

NOTE : Part number varies according to specification.

SEAL KIT

Part number **018/XPSK** contains all parts marked 'X' in part number indicates variable seal material. Please contact Sales for correct seal kit part number.

TABLE 1

Common Pressure Settings	Pressure Spring Part No.
96 PSI (6.62 Bar)	6104-0763
106 PSI (7.31 Bar)	6104-0840
110 PSI (7.59 Bar)	6104-0840

TABLE 2

Part No.	Drilling	Body
019/1XXX0650	DIN65 PN10	1860/0650E
019/1XXX0651	DIN80 PN6	1860/0651E
019/1XXX0653	3" BSTD	1860/0653E
019/1XXX0654	2½" ASA 150	1860/0654E
019/1XXX0655	3" ASA 150	1860/0655E
019/1XXX0657	DIN80 PN10	1860/0657E

Visual inspection and service (where necessary) is recommended regularly. A detailed step-by-step repair manual is available for our Super Maxi Relief Valves. Please contact our Sales team for further information.



Flanged Tapered Bore Super Maxi Relief Valve - flanged tank connection with 65 - 80mm tapered bore (see below for flange options). Suitable for a pressure range of between 2 - 70 PSI (0.14 - 4.83 Bar). Contact parts manufactured in 316 stainless steel. Fitted with Forty seals as standard.

Options - combined pressure/vacuum version. Alternative seal materials are available. Additional flange drillings are available.

Specification

Weight 5.85 Kg *Varies
 Temperature Range Dependant upon seal material

Design Approval by Lloyds Register of Shipping.

Tests may be witnessed and valves individually stamped by an independent inspectorate by arrangement.

Test certificates are supplied as standard.

Valve flow rates are available by request.

*** Fitting ancillary items in the flow stream will alter the valve flow rate.**

Range

Part No.	Description
013/1XX0066X	65 - 80mm tapered bore flanged Super Maxi valve

NB Above part number varies according to valve pressure and vacuum settings.

Associated Parts

Part No.	Description
921/07BBSP	0-100 PSI pressure gauge, bottom entry, brass internal parts
921/07RBSP	0-100 PSI pressure gauge, rear entry, brass internal parts
920/07BBSP	0-100 PSI pressure gauge, bottom entry, brass internal parts
176/2900 *	Removable clamped gauze
864/XXXX *	80mm bursting disc
311/3700	Stud kit (4 x M16)

Fitting Details

Example shown : 013/1XX0066X

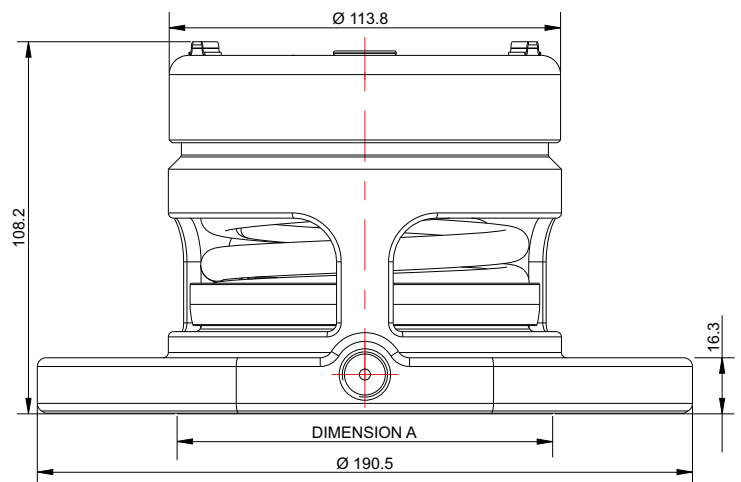
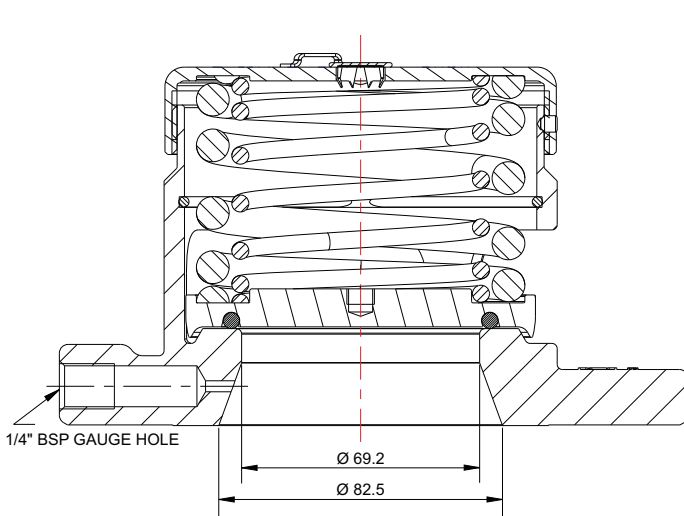

Part Number	Dimension A	Flange Drilling Pattern			Flange Spec.	Tank Weld in Pad	Gasket
		No. of Holes	Ø (mm) (equi-spaced)	PCD (mm)			
013/1XX00660	Ø 125.5	4	18	145.0	DIN 65 PN10	176/3245	5005-892
013/1XX00661	Ø 127.0	4	18	150.0	DIN 80 PN6	176/3158	5005-334
013/1XX00665	Ø 127.0	4	18	152.4	3" ASA 150	176/3125	5005-204

Parts Drawing

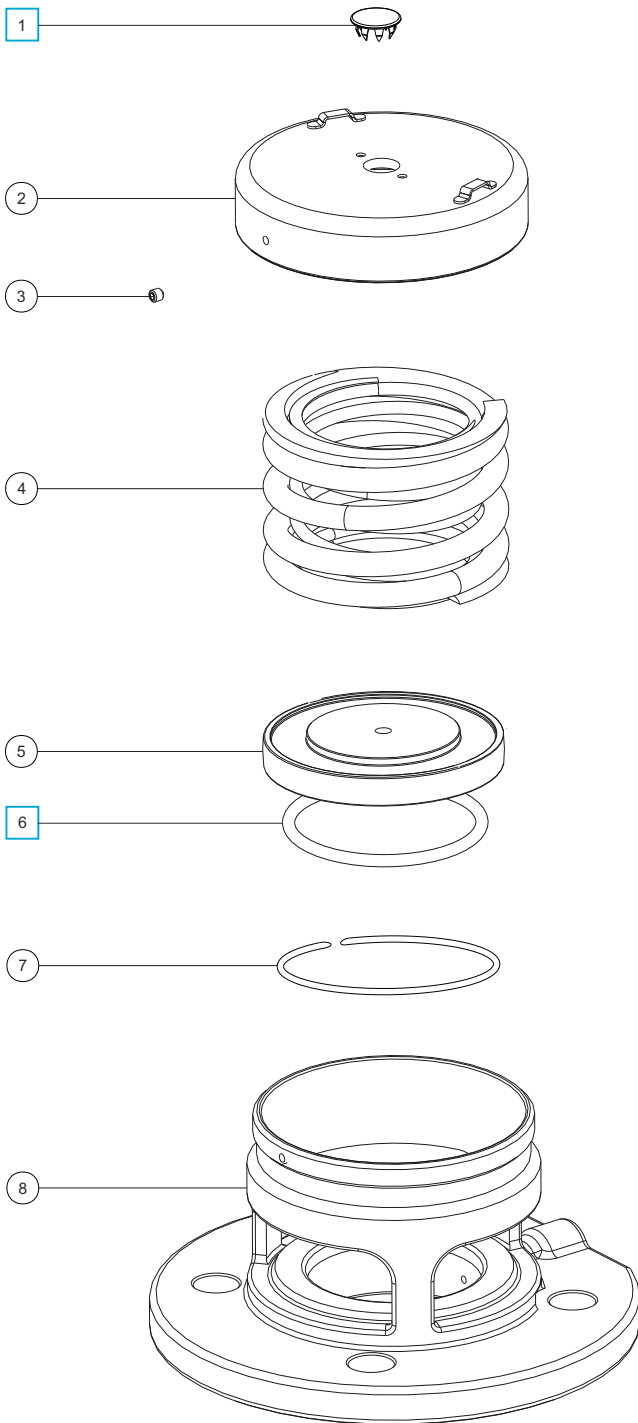

Item	Description	Part No.
1	Stainless steel plug	10978 <input type="checkbox"/>
2	Top cap	1760/0005
3	Setting locking grub screw	5121-001
4	Pressure spring *See Table 1	6104-XXXX
5	Pressure plate	1860/00XX
6	Fortyt pressure O ring	5005-101 <input type="checkbox"/>
7	Retaining ring clip	5120-067
8	Body *See Table 2	1860/066X

SEAL KIT

Part number **000/1PSK** contains all parts marked

TABLE 1

Common Pressure Settings	Pressure Spring Part No.
31.8 PSI (2.19 Bar)	6104-0252
48.0 PSI (3.31 Bar)	6104-0112 & 6104-0252
53.8 PSI (3.71 Bar)	6104-0422
63.8 PSI (4.40 Bar)	6104-0485

TABLE 2

Part No.	Drilling	Body
013/1XX00660	DIN65 PN10	1860/0660
013/1XX00661	DIN80 PN6	1860/0661
013/1XX00665	3" ASA150	1860/0665

Visual inspection and service (where necessary) is recommended regularly. A detailed step-by-step repair manual is available for our Super Maxi Relief Valves. Please contact our Sales team for further information.



Flanged Tapered Bore Super Maxi Relief Valve - flanged tank connection with 65 - 80mm tapered bore (see below for flange options). Suitable for a pressure range of between 2 - 70 PSI (0.14 - 4.83 Bar) and a vacuum range of between 0 - 24" Hg (0 - 0.81 Bar). Contact parts manufactured in 316 stainless steel. Fitted with Fortyt seals as standard.

Options - pressure only version. Alternative seal materials are available. Additional flange drillings are available.

Specification

Weight 5.82 Kg *Varies
 Temperature Range Dependant upon seal material

Design Approval by Lloyds Register of Shipping.

Tests may be witnessed and valves individually stamped by an independent inspectorate by arrangement.

Test certificates are supplied as standard.

Valve flow rates are available by request.

*** Fitting ancillary items in the flow stream will alter the valve flow rate.**

Range

Part No.	Description
013/1XXXX66X	65 - 80mm tapered bore flanged Super Maxi valve

NB Above part number varies according to valve pressure and vacuum settings.

Associated Parts

Part No.	Description
921/07BBSP	0-100 PSI pressure gauge, bottom entry, brass internal parts
921/07RBSP	0-100 PSI pressure gauge, rear entry, brass internal parts
920/07BBSP	0-100 PSI pressure gauge, bottom entry, stainless steel internal parts
176/2900 *	Removable clamped gauze
311/3700	Stud kit (4 x M16)

Fitting Details

Example shown : 013/1XXXX66X

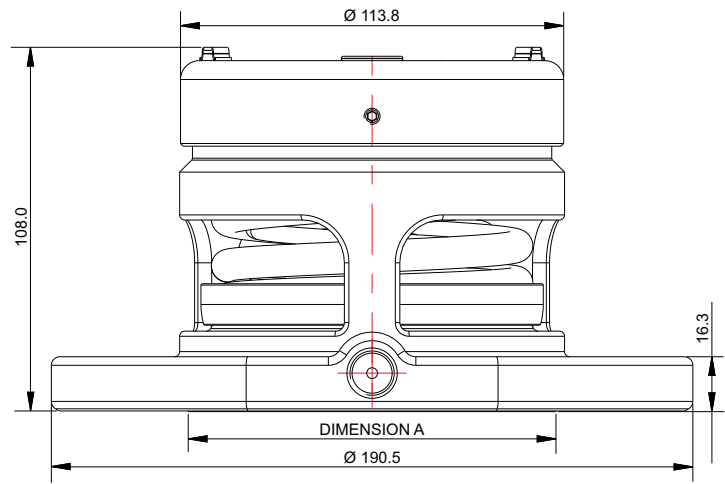
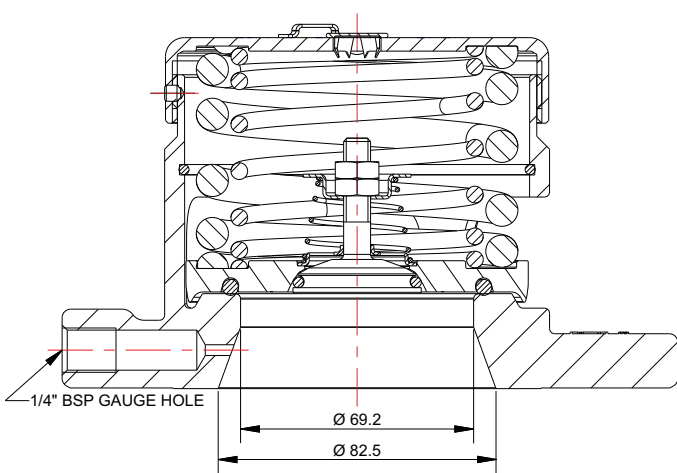

Part Number	Dimension A	Flange Drilling Pattern			Flange Spec.	Tank Weld in Pad	Gasket
		No. of Holes	Ø (mm) (equi-spaced)	PCD (mm)			
013/1XXXX660	Ø 109.2	4	18	145.0	DIN 65 PN10	176/3245	5005-892
013/1XXXX665	Ø 127.0	4	18	152.4	3" ASA 150	176/3125	5005-204

Parts Drawing

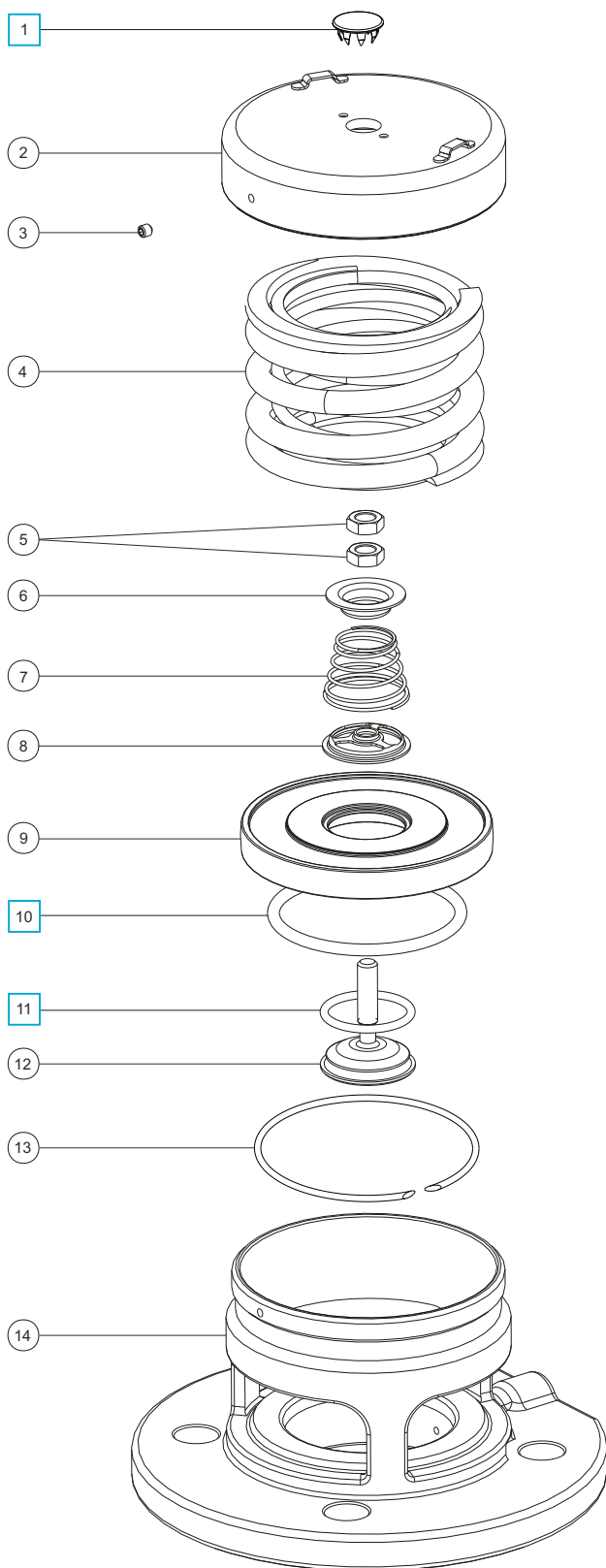

Item	Description	Part No.
1	Stainless steel plug	10978 <input type="checkbox"/>
2	Cap	1760/0005
3	Setting locking grub screw	5121-001
4	Pressure spring pair *See Table 1	6104-XXXX
5	M8 lock nut (2)	5112-004
6	Vacuum spring pad	1860/0005
7	Vacuum spring *See Table 2	7104-XXX
8	Spring pad	10986/3
9	Pressure plate	1860/XXXX
10	Fortyt pressure O ring	5005-101 <input type="checkbox"/>
11	Fortyt vacuum O ring	5005-108H <input type="checkbox"/>
12	Vacuum poppet	10983V/3
13	Retaining ring clip	5120-067
14	Body *See Table 3	1860/066X

SEAL KIT

Part number **000/1PVSK** contains all parts marked

TABLE 1

Common Pressure Settings	Pressure Spring Part No.
31.8 PSI (2.19 Bar)	6104-0252
48.0 PSI (3.31 Bar)	6104-0112 & 6104-0252
53.8 PSI (3.71 Bar)	6104-0422
63.8 PSI (4.40 Bar)	6104-0485

TABLE 2

Common Vacuum Settings	Vacuum Spring Part No.
3"Hg (-0.10 Bar)	7104-006
6"Hg (-0.20 Bar)	7104-012

TABLE 3

Part No.	Drilling	Body
013/1XX00650	DIN65 PN10	1860/0660
013/1XX00655	3" ASA150	1860/0665

Visual inspection and service (where necessary) is recommended regularly. A detailed step-by-step repair manual is available for our Super Maxi Relief Valves. Please contact our Sales team for further information.



Extended Body Flanged Tapered Bore Super Maxi Relief Valve - flanged tank connection with 69.2 - 82.6mm tapered bore (see below for flange options). Suitable for a pressure range of between 66 - 204 PSI (4.55 - 14.07 Bar). Contact parts manufactured in 316 stainless steel. Fitted with reinforced Fortyt seals as standard.

Options - combined pressure/vacuum version. 65mm and 80mm nominal bore range. Alternative seal materials are available. Additional flange drillings are available

Specification

Weight 7.43 Kg *Varies
Temperature Range Dependant upon seal material

Design Approval by Lloyds Register of Shipping.

Tests may be witnessed and valves individually stamped by an independent inspectorate by arrangement.

Test certificates are supplied as standard.

Valve flow rates are available by request.

*** Fitting ancillary items in the flow stream will alter the valve flow rate.**

Range

Part No.	Description
019/1XXX66X	Extended body flanged tapered bore Super Maxi valve

NB Above part number varies according to valve pressure and vacuum settings.

Associated Parts

Part No.	Description
920/20BBSP	0-200 PSI pressure gauge, bottom entry, stainless steel internal parts
921/20BBSP	0-200 PSI pressure gauge, bottom entry, brass internal parts
921/07RBSP	0-100 PSI pressure gauge, rear entry, brass internal parts
176/2900 *	Removable clamped gauze
864/XXXX *	80mm bursting disc
311/3700	Stud kit (4 x M16)

Fitting Details

Example shown : 019/1XXX066X

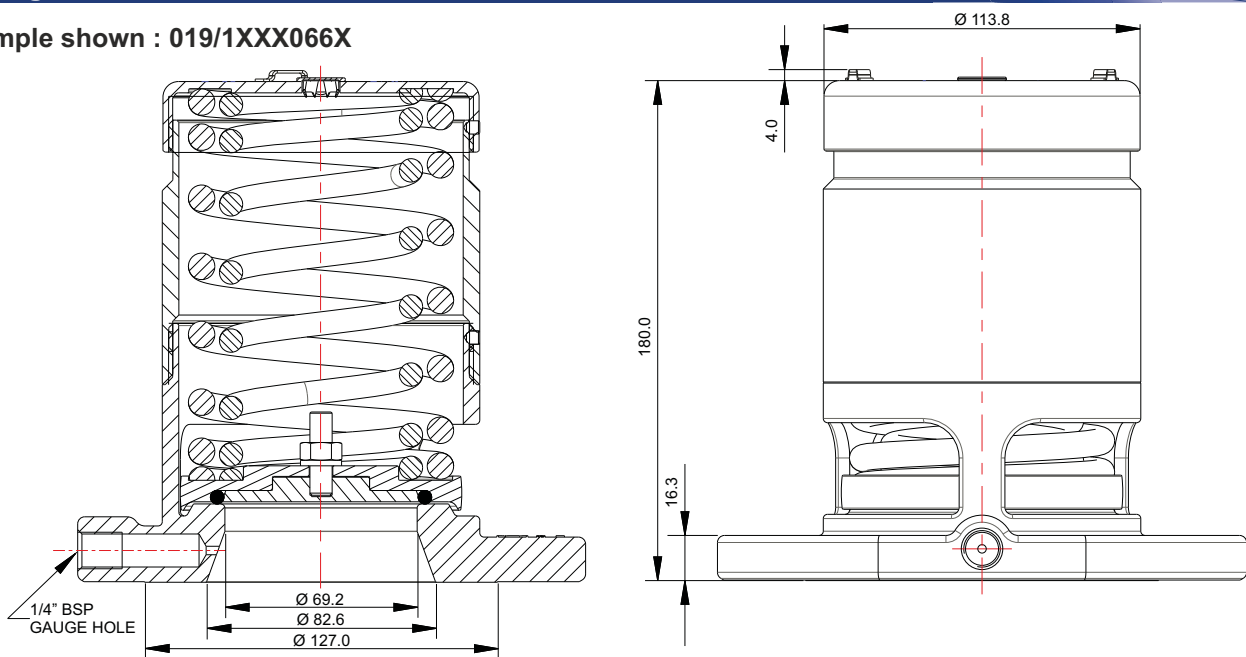

Part Number	Flange Drilling Pattern			Flange Spec.	Tank Weld in Pad	Gasket
	No. of Holes	Ø (mm) (equi-spaced)	PCD (mm)			
019/1XXX0660	4	18	145.0	DIN 65 PN10	176/3245	5005-892
019/1XXX0661	4	18	150.0	DIN 80 PN6	176/3158	5005-334
019/1XXX0663	4	18	146.1	3" BSTD	176/3140	5005-397
019/1XXX0665	4	18	152.4	3" ASA 150	176/3125	5005-204

Parts Drawing

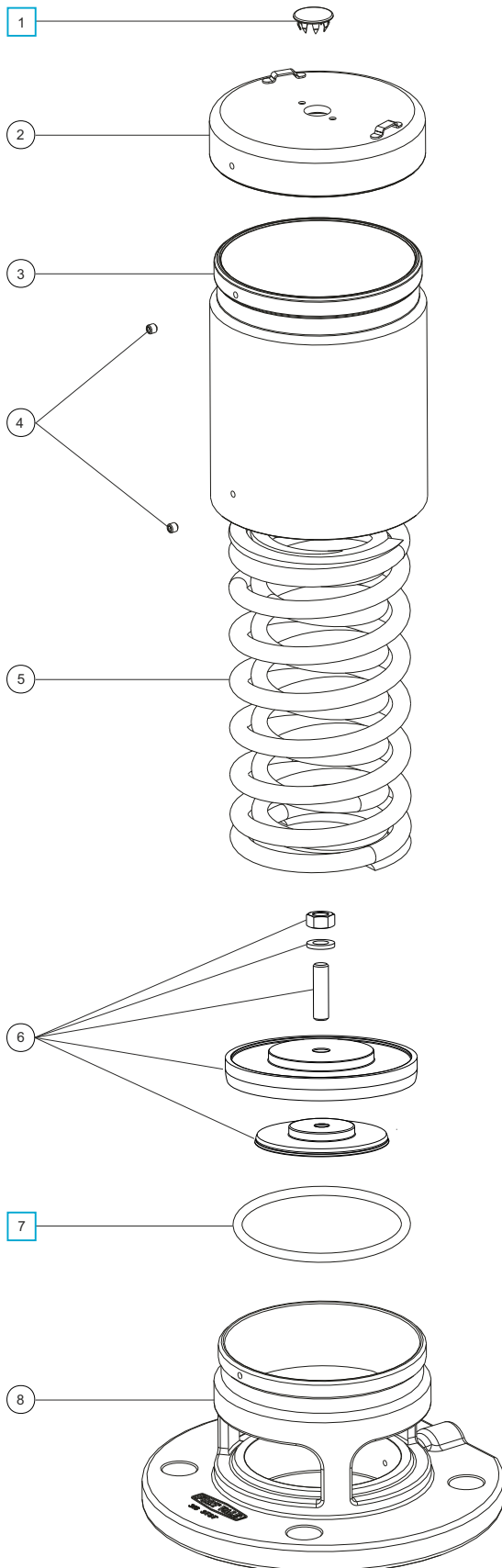

Item	Description	Part No.
1	Stainless steel plug	10978 <input type="checkbox"/>
2	Top cap	1760/0005
3	Extension tube	1860/0035
4	Setting locking grub screw (2)	5121-001
5	Pressure spring pair *See Table 1	6104-XXXX
6	Pressure plate *See Note	1860/00XX
7	Pressure O ring *See Note	5005-XXX <input type="checkbox"/>
8	Body *See Table 2	1860/066X

NOTE : Part number varies according to specification.

SEAL KIT

Part number **018/XPSK** contains all parts marked 'X' in part number indicates variable seal material. Please contact Sales for correct seal kit part number.

TABLE 1

Common Pressure Settings	Pressure Spring Part No.
100 PSI (6.89 Bar)	6104-0763
106 PSI (7.31 Bar)	6104-0840
110 PSI (7.58 Bar)	6104-0840

TABLE 2

Part No.	Drilling	Body
019/1XXX0660	DIN65 PN10	1860/0660
019/1XXX0661	DIN80 PN6	1860/0661
019/1XXX0663	3" BSTD	1860/0663
019/1XXX0665	3" ASA150	1860/0665

Visual inspection and service (where necessary) is recommended regularly. A detailed step-by-step repair manual is available for our Super Maxi Relief Valves. Please contact our Sales team for further information.



82.5mm Flanged Hyper Maxi Pressure Only Relief Valve - Flange drilled 4 slots with a 145.0/152.4mm min/max PCD. (See below for drilling details) Suitable for a set pressure range of *2 to 75 PSI (*0.14 to 5.17 Bar) *See Note under Specification. Contact parts manufactured in 316 stainless steel. Fitted with Fortyt seal as standard.

Options - combined pressure/vacuum version. High pressure extended body version. Alternative seal materials are available.

Fort Vale offers a full range of threaded and flanged relief valves.

Specification

Weight	5.6 Kg *
Design Pressure (MAWP)	5.2 Bar (75 PSIG)
Test Pressure	10.1 Bar (147 PSIG)

*Weight varies according to valve specification.
Temperature range : Dependant upon seal material.

Design Approval by Lloyds Register of Shipping.
*Note: Scope of Approval covers valves set at 25 PSI (1.7 Bar) and above.

Valve Flow Data

Please contact sales@fortvale.com and request data sheet reference: 043/049/82/5/FLOW/NORM.
See below for de-rations.
Test certificates supplied as standard.

De-rations

Description	De-ration
Valve with removable gauze (176/2920)	-5.01%
Valve with 80mm Icon CDC burst disc (864/XXXX)	-15.00%
Valve with removable gauze (176/2920) and 80mm Icon CDC burst disc (864/XXXX)	-15.61%

Drilling Details & Fittings

Specification	PCD	Weld-in Flange	Gasket
DIN65 PN10	145.0mm	176/3250	5005-332
3" Table D	146.1mm	176/3140	5005-013
DIN80 PN6	150.0mm	176/3158	5005-334
3" ASA 150	152.4mm	176/3125	5005-204

Associated Parts

Part No.	Associated Parts
921/07BBSP	0-100 PSI pressure gauge, bottom entry, brass internal parts
921/07RBSP	0-100 PSI pressure gauge, rear entry, brass internal parts
920/07BBSP	0-100 PSI pressure gauge, bottom entry, stainless steel internal parts
176/2920	Removable clamped gauze
864/XXXX	80mm bursting disc
311/3700	Stud kit (4 x M16)
311/3785	Bolt kit (cap screws) - 145/146mm PCD

Range

Part No.	Description
043/XXX0082S	82.5mm standard pressure only
043/XXXXX82S	82.5mm standard pressure/vacuum
049/XXXXX0082S	82.5mm extended pressure only
049/XXXXXX82S	82.5mm extended pressure/vacuum

Fitting Details

Part Number : 043/XXX0082S - Depicted with removable gauze

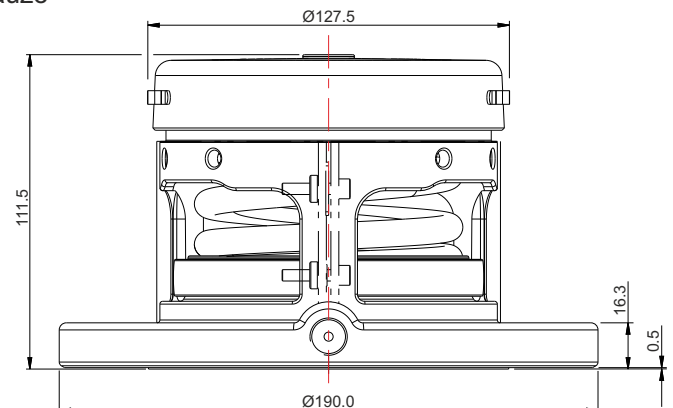
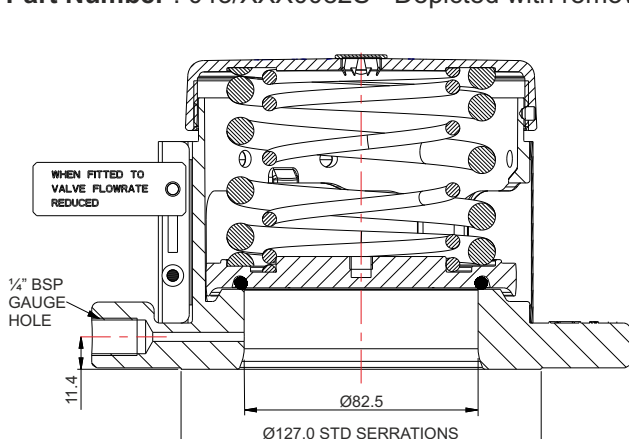

Parts drawing

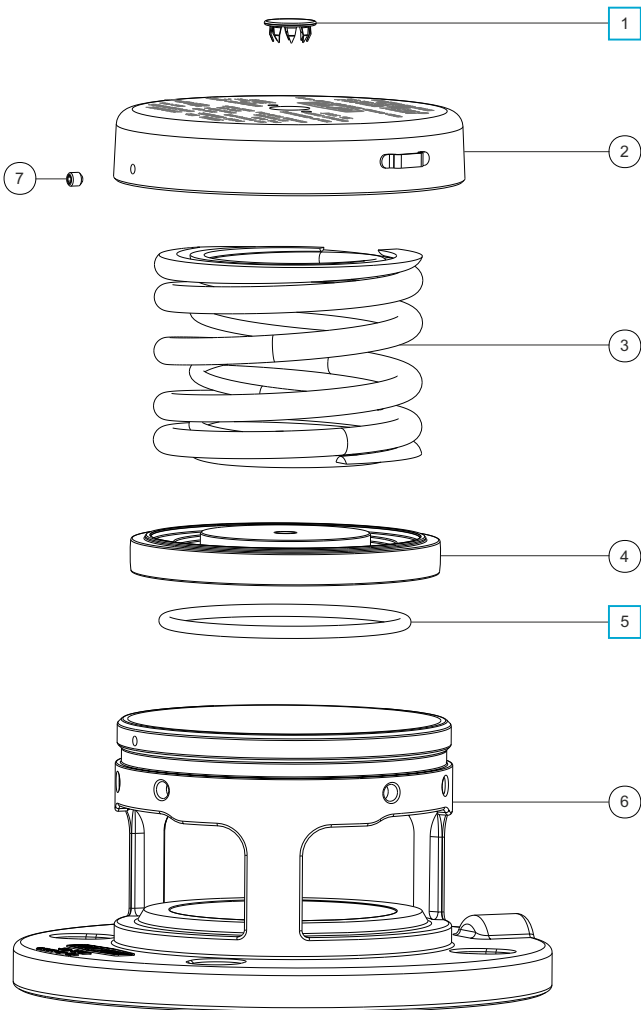

Item	Description	Part No.
1	Stainless steel plug	10978 <input type="checkbox"/>
2	Top cap *See Note	1860/1008XX
3	Spring *See Table 1	610X-XXXX
4	Pressure plate *See Note	1860/1070XXX
5	Fortyt O ring	ORB337F0 <input type="checkbox"/>
6	Body	1860/19SL
7	Grubscrew	5121-001

NOTE : Part number varies according to specification.

SEAL KIT

Part number **043/1PSK** contains all parts marked

TABLE 1

Common Pressure Settings	Pressure Spring Part No.
15.0 PSI (1.03 Bar)	6109-0674
31.8 PSI (2.19 Bar)	6104-0048 & 6104-0310
48.0 PSI (3.31 Bar)	6104-0485 (Pair)
53.8 PSI (3.71 Bar)	6104-0570 (Pair)
63.8 PSI (4.40 Bar)	6104-0665 (Pair)

Pressure springs are available from 2 PSI (0.14 Bar) to 75 PSI (5.17 Bar)

Visual inspection and service (where necessary) is recommended on a 6 monthly basis.



82.5mm Flanged Hyper Maxi Pressure/Vacuum Relief Valve - Flange drilled 4 slots with a 145.0/152.4mm min/max PCD. (See below for drilling details) Suitable for a set pressure range of *2 to 75 PSI (*0.14 to 5.17 Bar) *See Note under Specification, and a set vacuum range of 0.5"Hg to 26"Hg (0.02 to 0.88 Bar). Contact parts manufactured in 316 stainless steel. Fitted with Forty seals as standard.

Options - pressure only version. High pressure extended body version. Alternative seal materials are available.

Fort Vale offers a full range of threaded and flanged relief valves.

Specification

Weight	5.9 Kg *
Design Pressure (MAWP)	5.2 Bar (75 PSIG)
Test Pressure	10.1 Bar (147 PSIG)

*Weight varies according to valve specification.
Temperature range : Dependant upon seal material.

Design Approval by Lloyds Register of Shipping.
*Note: Scope of Approval covers valves set at 25 PSI (1.7 Bar) and above.

Valve Flow Data

Please contact sales@fortvale.com and request data sheet reference: 043/049/82/5/FLOW/NORM.
See below for de-rations.
Test certificates supplied as standard.

Drilling Details & Fittings

Specification	PCD	Weld-in Flange	Gasket
DIN65 PN10	145.0mm	176/3250	5005-332
3" Table D	146.1mm	176/3140	5005-013
DIN80 PN6	150.0mm	176/3158	5005-334
3" ASA 150	152.4mm	176/3125	5005-204

Associated Parts

Part No.	Associated Parts
921/07BBSP	0-100 PSI pressure gauge, bottom entry, brass internal parts
921/07RBSP	0-100 PSI pressure gauge, rear entry, brass internal parts
920/07BBSP	0-100 PSI pressure gauge, bottom entry, stainless steel internal parts
176/2920	Removable clamped gauge
311/3700	Stud kit (4 x M16)
311/3785	Bolt kit (cap screws) - 145/146mm PCD

De-rations

Description	De-ration
Valve with removable gauge (176/2920)	-5.01%

Range

Part No.	Description
043/XXX0082S	82.5mm standard pressure only
043/XXXXX82S	82.5mm standard pressure/vacuum
049/XXX0082S	82.5mm extended pressure only
049/XXXXX82S	82.5mm extended pressure/vacuum

Fitting Details

Part Number : 043/XXXXX82S - Depicted with removable gauge

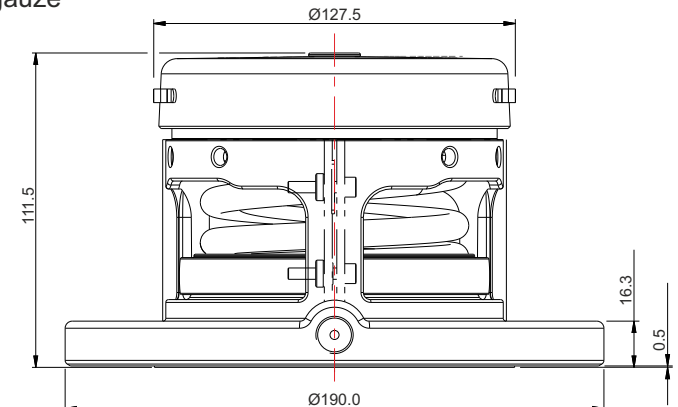
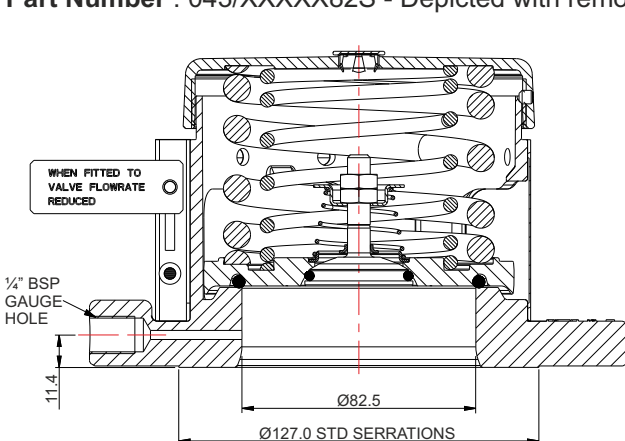

Parts drawing

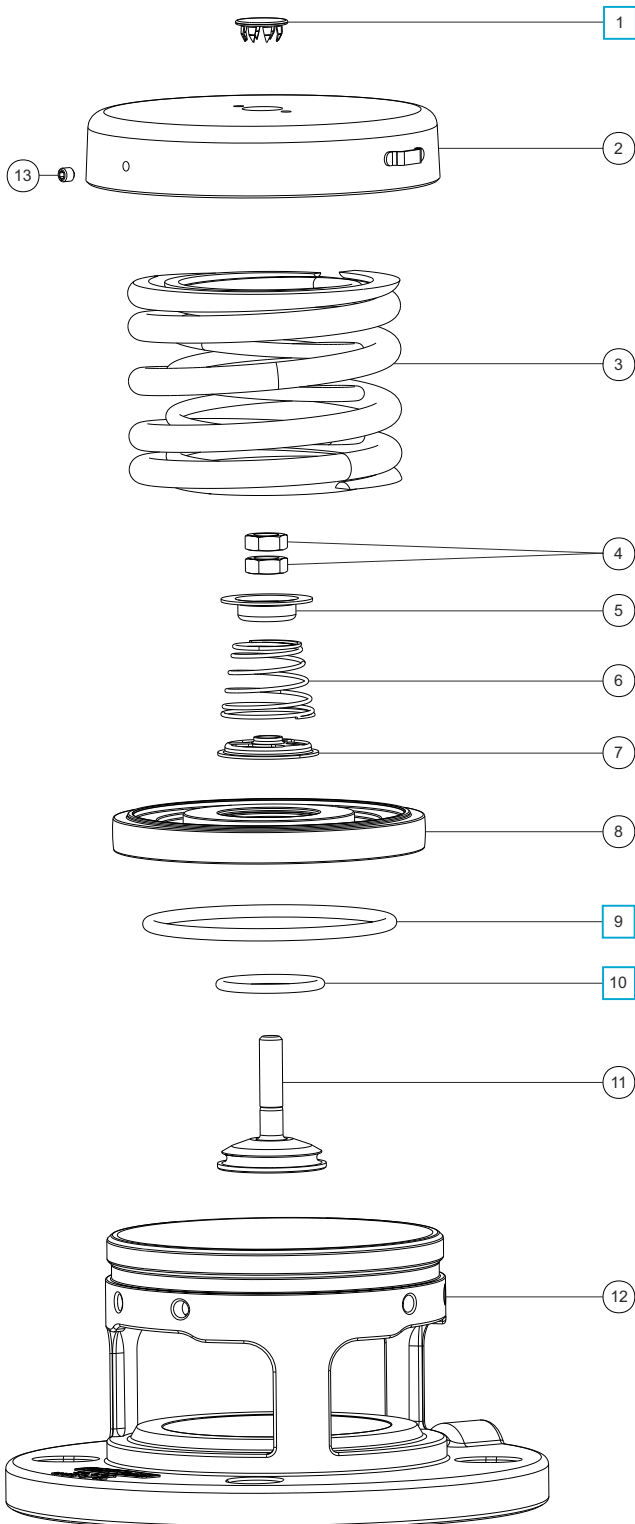

Item	Description	Part No.
1	Stainless steel plug	10978
2	Top cap *See Note	1860/1008XX
3	Spring *See Table 1	610X-XXXX
4	Half nut (2)	5112-004
5	Vacuum spring pad	1860/0005
6	Vacuum spring *See Table 2	7104-XXX
7	Spring pad	10986/3
8	Pressure plate *See Note	1860/1071XX
9	Fortyt pressure O ring	ORB337F0
10	Fortyt vacuum O ring	5005-108H
11	Vacuum poppet	10983V/3
12	Body	1860/19SL
13	Grubscrew	5121-001

NOTE : Part number varies according to specification.

SEAL KIT

Part number **043/1PVSK** contains all parts marked

TABLE 1

Common Pressure Settings	Pressure Spring Part No.
15.0 PSI (1.03 Bar)	6109-0674
31.8 PSI (2.19 Bar)	6104-0048 & 6104-0310
48.0 PSI (3.31 Bar)	6104-0485 (Pair)
53.8 PSI (3.71 Bar)	6104-0570 (Pair)
63.8 PSI (4.40 Bar)	6104-0665 (Pair)

Pressure springs are available from 2 PSI (0.14 Bar) to 75 PSI (5.17 Bar)

TABLE 2

Common Vacuum Setting	Vacuum Spring Part No.
6.2"Hg (0.21 Bar)	7104-012

Vacuum springs are available from 0.5"Hg (0.02 Bar) to 26"Hg (0.88 Bar)

Visual inspection and service (where necessary) is recommended on a 6 monthly basis.



82.5mm Flanged Extended Hyper Maxi Pressure Only Relief Valve - Flange drilled 4 slots with a 145.0/152.4mm min/max PCD. (See below for drilling details) Suitable for a set pressure range of 75 to 204 PSI (5.17 to 14.07 Bar). Contact parts manufactured in 316 stainless steel. Fitted with Forty seals as standard.

Options - pressure/vacuum version. Standard body version for pressure below 75 PSI. Alternative seal materials are available.

Fort Vale offers a full range of threaded and flanged relief valves.

Specification

Weight 8.9 Kg *Note

Note : Weight and all other design conditions vary according to valve specification.

Design Approval by Lloyds Register of Shipping.

Valve Flow Data

Please contact sales@fortvale.com and request document reference 043/049/82/5/FLOW/NORM. See below for de-rations. Test certificates supplied as standard.

De-rations

Description	De-ration
Valve with removable gauze (176/2920)	-5.01%
Valve with 80mm Icon CDC burst disc (864/XXXX)	-15.00%
Valve with removable gauze (176/2920) and 80mm Icon CDC burst disc (864/XXXX)	-15.61%

Drilling Details & Fittings

Specification	PCD	Weld-in Flange	Gasket
DIN65 PN10	145.0mm	176/3250	5005-332
3" Table D	146.1mm	176/3140	5005-013
DIN80 PN6	150.0mm	176/3158	5005-334
3" ASA 150	152.4mm	176/3125	5005-204

Associated Parts

Part No.	Associated Parts
921/20BBSP	0-290 PSI pressure gauge, bottom entry, brass internal parts, 1/4" BSP connection
176/2920	Removable clamped gauze
864/XXXX	80mm bursting disc
311/3700	Stud kit (4 x M16)
311/3785	Bolt kit (cap screws) - 145/146mm PCD

Range

Part No.	Description
043/XXX0082S	82.5mm standard pressure only
043/XXXXX82S	82.5mm standard pressure/vacuum
049/XXXX0082S	82.5mm extended pressure only
049/XXXXXX82S	82.5mm extended pressure/vacuum

Fitting Details

Part Number : 049/XXXX0082S

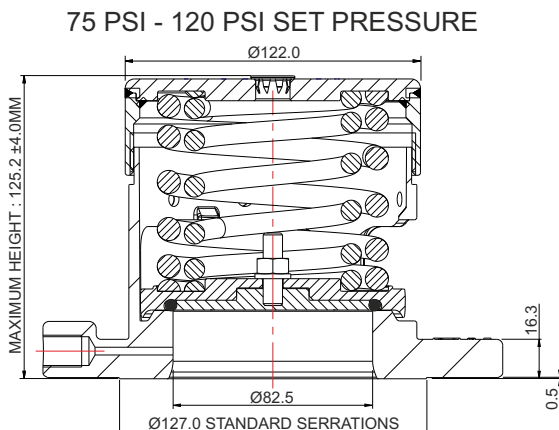

ABOVE 120 PSI SET PRESSURE

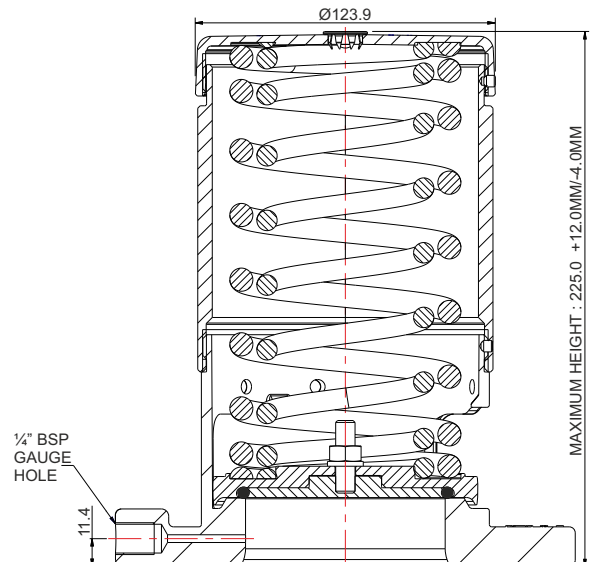

Parts drawing

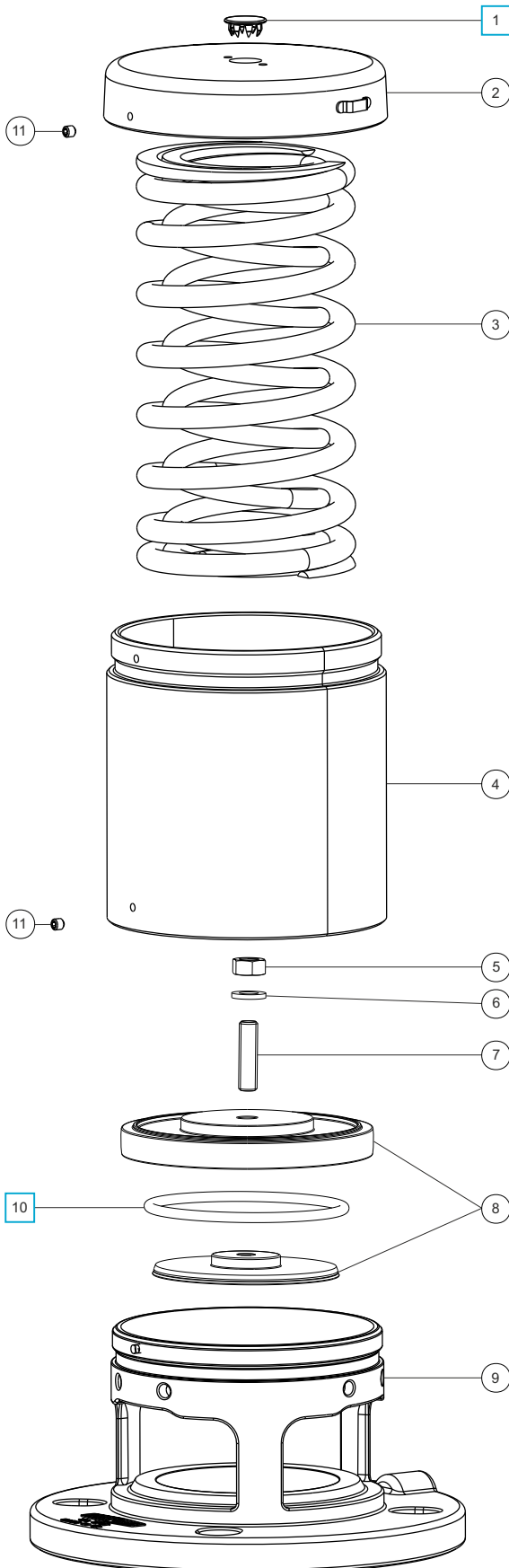

Item	Description	Part No.
1	Stainless steel plug	10978 <input type="checkbox"/>
2	Top cap *See Note 1	1860/XXXXXX
3	Spring *See Note 1	6104-XXXX
4	Extension tube *See Note 2	1860/1025/X
5	Full nut	5112-001
6	Spring washer	5113-003
7	Stud	11426
8	Pressure plate assy. *See Note 1	1860/X031XX
9	Body	1860/19SL
10	Fortyt O ring *See Note 1	ORB337F0 <input type="checkbox"/>
11	Grubscrew (2)	5121-001

NOTE 1 : Part number varies according to specification.

NOTE 2 : An extension tube is fitted to valves with a set pressure over 120 PSI (8.28 Bar). The part number varies according to the length of tube required.

SEAL KIT

Part number **043/1PSK** contains all parts marked

Visual inspection and service (where necessary) is recommended on a 6 monthly basis.



82.5mm Flanged Extended Hyper Maxi Pressure/Vacuum Relief Valve - Flange drilled 4 slots with a 145.0/152.4mm min/max PCD. (See below for drilling details) Suitable for a set pressure range of 75 to 204 PSI (5.17 to 14.07 Bar) and a set vacuum range of 0.5"Hg to 24"Hg (0.02 to 0.81 Bar). Contact parts manufactured in 316 stainless steel. Fitted with Fortyt seals as standard.

Options - pressure only version. Standard body version for pressure below 75 PSI. Alternative seal materials are available.

Fort Vale offers a full range of threaded and flanged relief valves.

Specification

Weight 8.8 Kg *Note

Note : Weight and all other design conditions vary according to valve specification.

Design Approval by Lloyds Register of Shipping.

Valve Flow Data

Please contact sales@fortvale.com and request data sheet reference 043/049/82/5/FLOW/NORM.

See below for de-rations.

Test certificates supplied as standard.

Drilling Details & Fittings

Specification	PCD	Weld-in Flange	Gasket
DIN65 PN10	145.0mm	176/3250	5005-332
3" Table D	146.1mm	176/3140	5005-013
DIN80 PN6	150.0mm	176/3158	5005-334
3" ASA 150	152.4mm	176/3125	5005-204

Associated Parts

Part No.	Associated Parts
921/20BBSP	0-290 PSI pressure gauge, bottom entry, brass internal parts, 1/4" BSP connection
176/2920	Removable clamped gauze
311/3700	Stud kit (4 x M16)
311/3785	Bolt kit (cap screws) - 145/146mm PCD

De-rations

Description	De-ration
Valve with removable gauze (176/2920)	-5.01%

Range

Part No.	Description
043/XXX0082S	82.5mm standard pressure only
043/XXXXX82S	82.5mm standard pressure/vacuum
049/XXXX0082S	82.5mm extended pressure only
049/XXXXXX82S	82.5mm extended pressure/vacuum

Fitting Details

Part Number : 049/XXXXXX82S

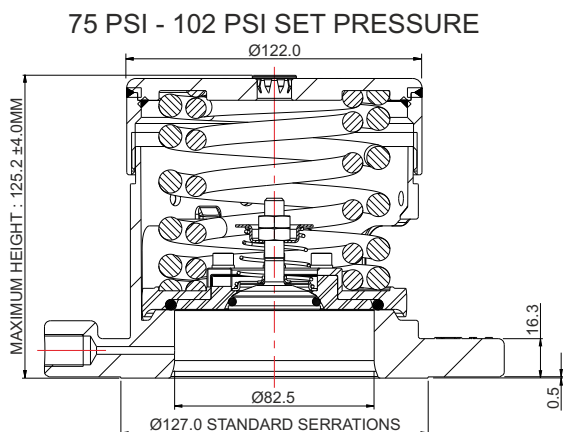

ABOVE 102 PSI SET PRESSURE

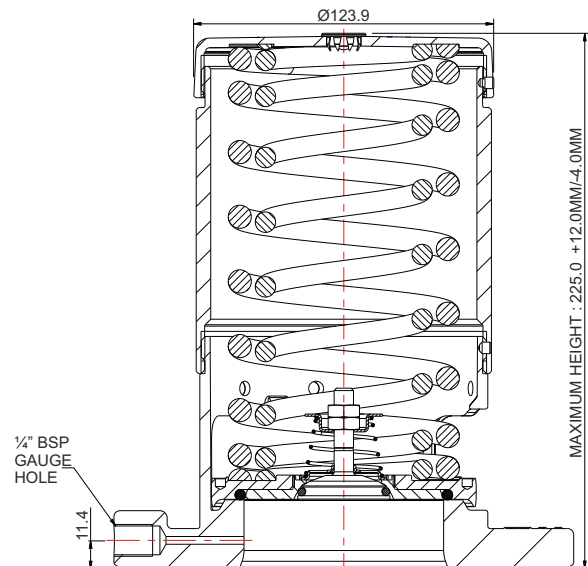

Parts drawing

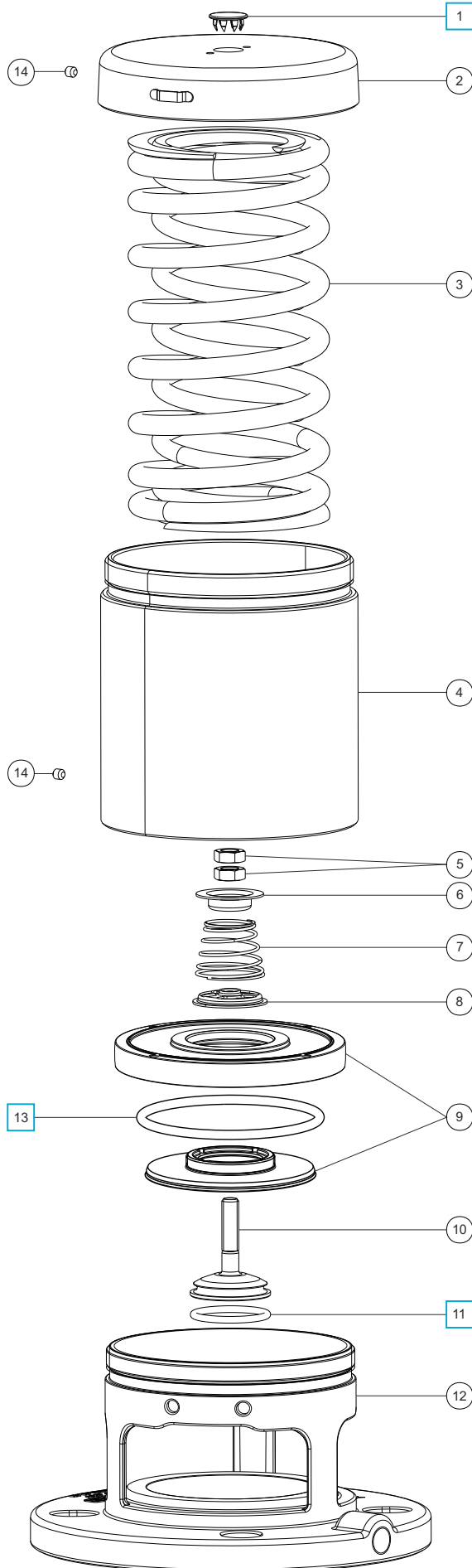

Item	Description	Part No.
1	Stainless steel plug	10978 <input type="checkbox"/>
2	Top cap *See Note 1	1860/XXXXXX
3	Spring *See Note 1	6104-XXXX
4	Extension tube *See Note 2	1860/1025/X
5	M8 half nut (2)	5112-004
6	Vacuum spring pad	1860/0005
7	Vacuum spring *See Table 1	7104-XXX
8	Spring pad	10986/3
9	Pressure plate assy. *See Note 1	1860/X03XXX
10	Vacuum poppet	10983V/3
11	Fortyt vacuum O ring	5005-108H <input type="checkbox"/>
12	Body *See Note 1	1860/19SL
13	Fortyt O ring *See Note 1	ORB337F0 <input type="checkbox"/>
14	Grubscrew (2)	5121-001

NOTE 1 : Part number varies according to specification.

NOTE 2 : An extension tube is fitted to valves with a set pressure over 102 PSI (7.03 Bar). The part number varies according to the length of tube required.

TABLE 1

Common Vacuum Setting	Vacuum Spring Part No.
6.2"Hg (0.21 Bar)	7104-012

Vacuum springs are available from 0.5"Hg (0.02 Bar) to 24"Hg (0.81 Bar)

SEAL KIT

Part number **043/1PVSK** contains all parts marked

Visual inspection and service (where necessary) is recommended on a 6 monthly basis.

Service Note

Please note that there are 2 different designs of pressure plate assembly, depending upon the spring set pressure. A specialist tool is required to service pressure plate type 1860/X032XX

Tool part number : FIX/A/0010B

Please contact sales@fortvale.com for further maintenance information.



2½" Super Maxi Pressure/Vacuum Relief Valve with 80mm DIN11851 connection - Suitable for a pressure range of between 2 PSI to 75 PSI (0.14 Bar to 5.17 Bar) and a vacuum range of between 0.5"Hg to 24"Hg (0.02 Bar to 0.81 Bar). Contact parts manufactured in 316 stainless steel fitted with Fortyt seal (FEP encapsulated silicone O ring) as standard. Supplied complete with DIN 11851 fitting nut.

Options - pressure only version. Different tank connections available. Alternative seal materials.

Specification

Weight	5.35 Kg
Design Pressure (MAWP)	5.2 Bar (75 PSI)
Test Pressure	10.1 Bar (147 PSI)
Fortyt Seal Temperature Range	-55°C to 200°C

In-house test certificates confirming valve setting and serial number supplied as standard.

Visual inspection and service (where necessary) is recommended on a 6 monthly basis.

Range

Part No.	Description
01M/XXX00	80mm DIN11851 pressure only
01M/XXXXX	80mm DIN11851 pressure/vacuum
01J/XXXXX	3" RJT pressure/vacuum *Note

Note : See 3" RJT section view under Fitting Details

Associated Parts

Part No.	Associated Parts
176/2550	80mm DIN11851 fitting socket
176/2685S	Silicone seal to suit 80mm DIN fittings
176/2900	Clamped gauze ring

Fitting Details

DIN11851 Connection
Part Number : 01M/XXXXX

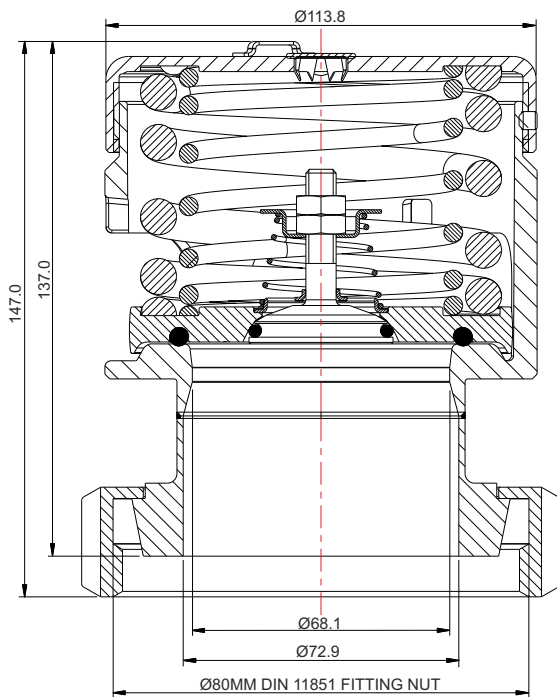

Alternative Connection - 3" RJT
Part Number : 01J/XXXXX

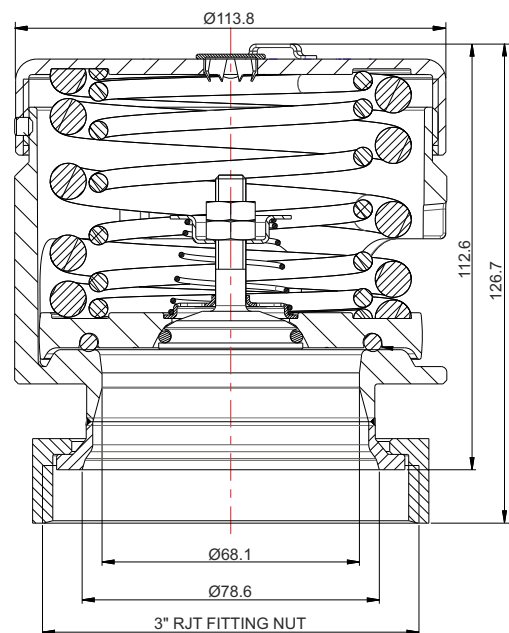

Parts Drawing

DIN11851 Connection

Part Number : 01M/XXXXX

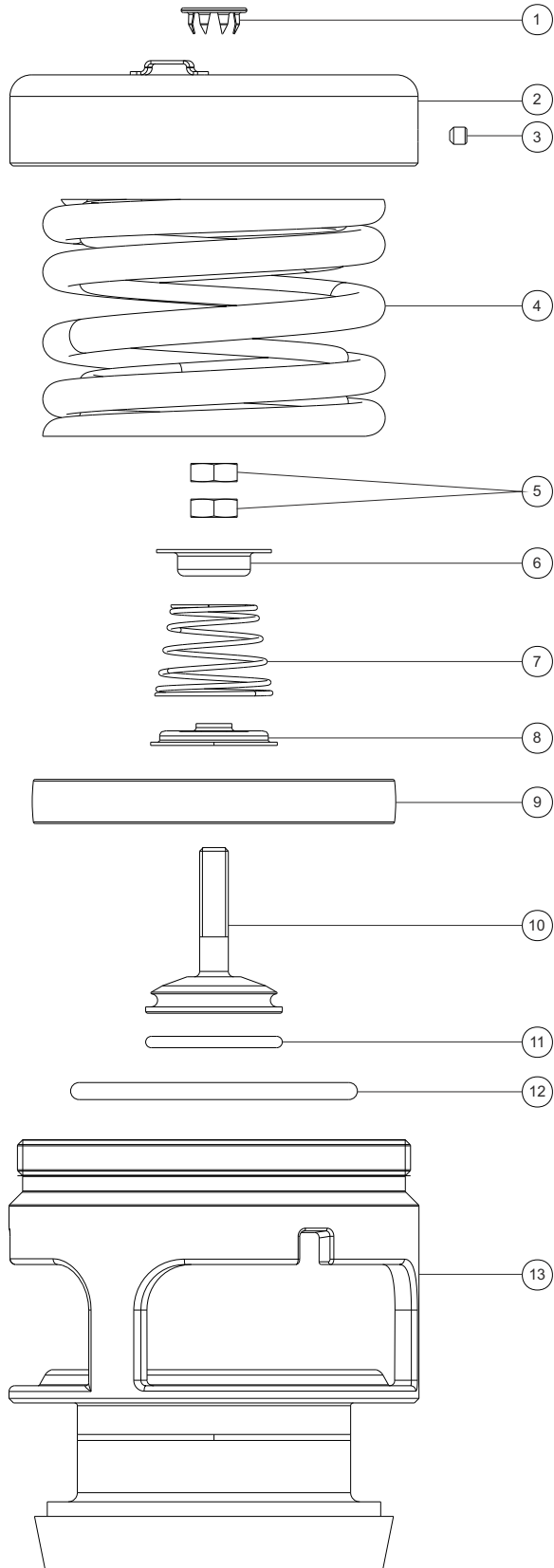

Item	Description	Part No.
1	Stainless steel plug	10978
2	Cap	1760/0005
3	Sockethead screw	5121-001
4	Pressure spring pair (See Note)	6104-XXX
5	M8 half nut (2)	5112-004
6	Vacuum spring pad	1860/0005
7	Vacuum spring (See Note)	7104-XXX
8	Spring pad	10986/3
9	Pressure plate (See Note)	1860/XXXX
10	Vacuum poppet (See Note)	10983X
11	Fortyt vacuum O ring (See Note)	5005-108H
12	Fortyt pressure O ring (See Note)	5005-101
13	80mm DIN11851 valve body	1860/0150

NOTE : Part number varies according to valve specification.



2½" BSP Foodgrade Extended Body Relief Valve - Designed and tested for incompressible fluid flow. 2½" BSP male connection with 65mm NB. Suitable for a pressure range of between 3 - 101 PSI (0.21 - 6.97 Bar) and a standard vacuum setting of 0.5"Hg (0.02 Bar). Contact parts manufactured in 316 stainless steel. Fitted with Fortyt and EPDM seals.

Options - Additional vacuum settings are available. Valve with 100mm DIN11851 milk fitting available.

Specification

Weight 4.78 Kg *Varies
 Design Temperature Dependant upon seal material

Design approval by Lloyds Register of Shipping.

Tests may be witnessed and valves individually stamped by an independent inspectorate by arrangement.

Test certificates supplied as standard.

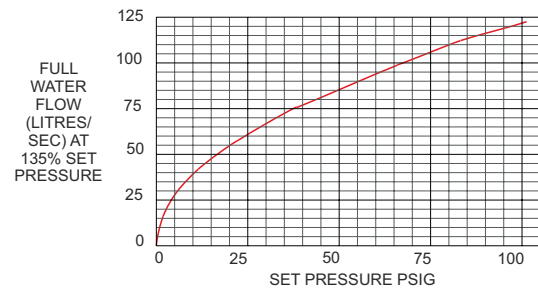

Range

Part No.	Description
0S/5XXXX	2½" BSP Foodgrade relief valve

Associated Parts

Part No.	Associated Parts
600/1000	2½" BSP weld-in socket
176/3156	Hygienic tank weld-in pad
920/07BBSP	0-100 PSIG pressure gauge, bottom entry, stainless steel internal parts
921/07BBSP	0-100 PSIG pressure gauge, bottom entry, brass internal parts
921/07RBSP	0-100 PSIG pressure gauge, rear entry, brass internal parts
176/2900 *	Removable clamped gauze

* Fitting ancillary items in the flow stream will affect the valve flow rate.

Fitting Details

Example shown : 0S/5XXXX

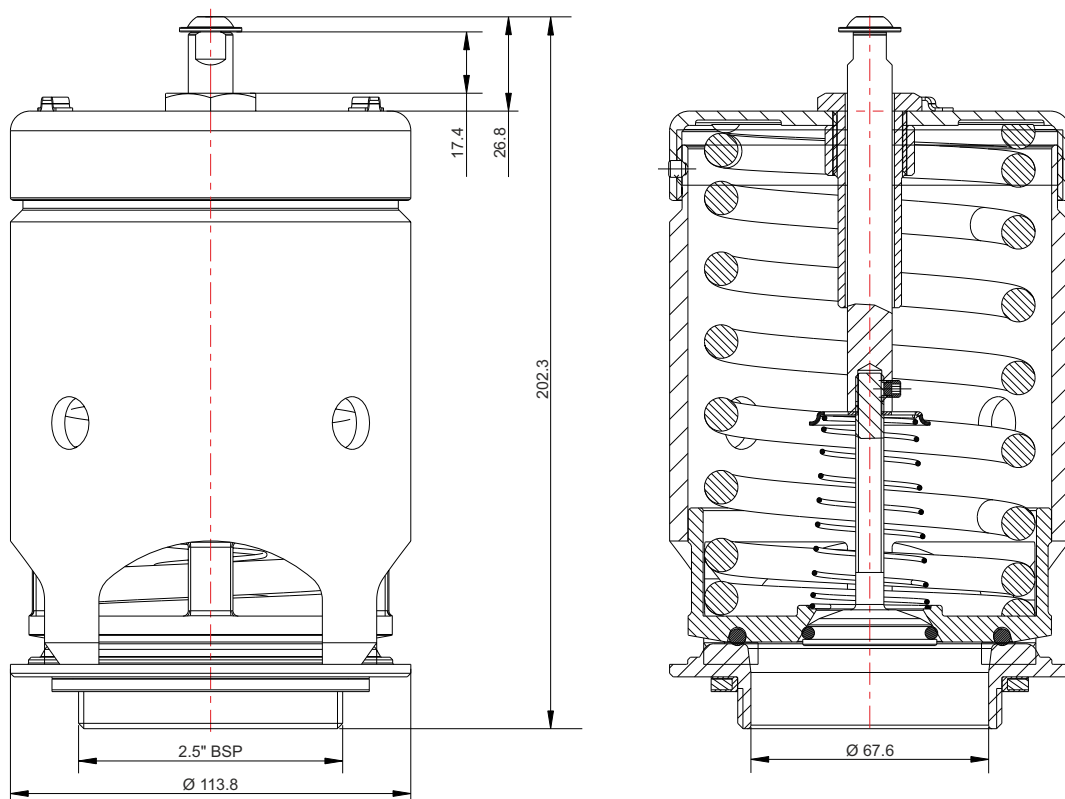

Fitting Details

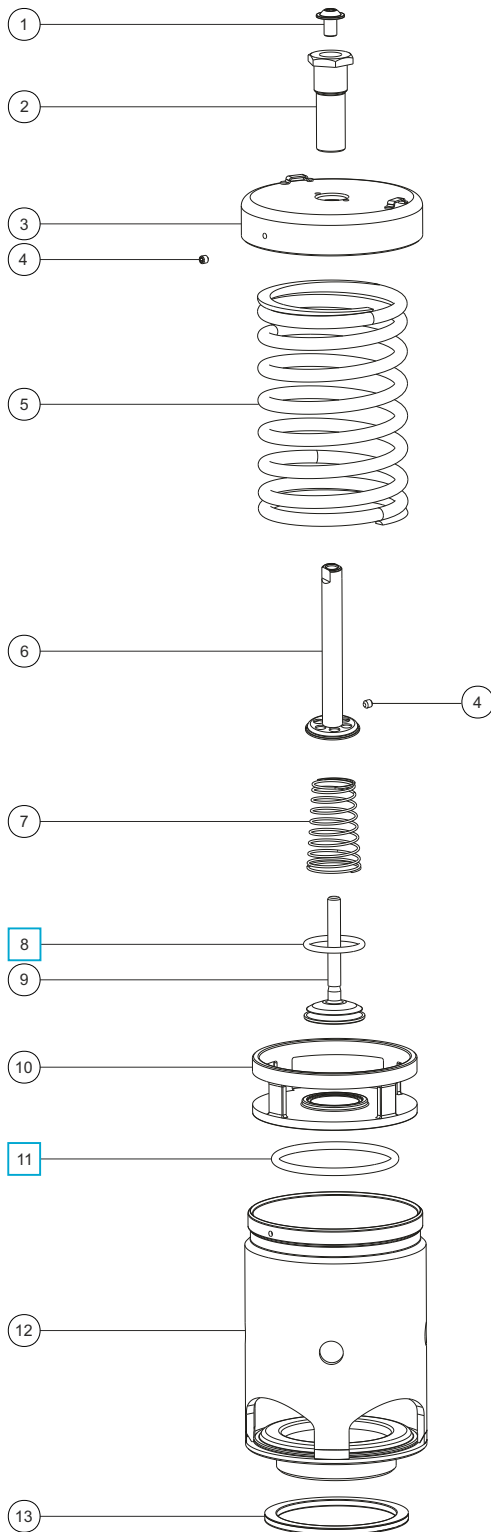

Item	Description	Part No.
1	Flanged button screw	5111-9812
2	Adjusting screw	175/0005
3	Cap assembly	176/0009
4	Grubscrew (2)	5121-001
5	Pressure spring *See Table 1	5104-XXX
6	Spring pad assembly	176/0067
7	Vacuum spring *See Table 2	5104-XXX
8	EPDM O ring	5005-255 <input type="checkbox"/>
9	Vacuum poppet	230/0045
10	Pressure plate	176/0062
11	Fortyt O ring	5005-101 <input type="checkbox"/>
12	Body	176/0610
13	Rubber/PTFE envelope seal	5005-046

SEAL KIT

Part number 000/5PVSK contains all parts marked

TABLE 1

Pressure Setting	Pressure Spring	Full Water Flow (Litres/Sec)	At Pressure (PSIG)
3 PSI (0.21 Bar)	5104-947	21.3	4.1
7 PSI (0.48 Bar)	5104-946	33.0	9.5
13 PSI (0.90 Bar)	5104-969	44.3	17.6
14 PSI (0.97 Bar)	5104-923	46.0	18.9
15 PSI (1.03 Bar)	5104-923	47.5	20.3
17 PSI (1.17 Bar)	5104-922	50.6	23.0
18 PSI (1.24 Bar)	5104-922	52.1	24.3
20 PSI (1.38 Bar)	5104-804	55.0	27.0
22 PSI (1.52 Bar)	5104-940	57.6	29.7
25 PSI (1.72 Bar)	5104-912	61.4	33.8
26 PSI (1.79 Bar)	5104-912	62.6	35.1
27 PSI (1.86 Bar)	5104-927	63.8	36.5
29 PSI (2.00 Bar)	5104-921	66.1	39.2
35 PSI (2.41 Bar)	5104-958	72.6	47.3
37 PSI (2.55 Bar)	5104-859	75.0	50.0
43 PSI (2.96 Bar)	5104-955	80.5	58.1
50 PSI (3.45 Bar)	5104-950	87.0	67.5
101 PSI (6.96 Bar)	5104-994	123.3	136.4

TABLE 2

Common Vacuum Settings	Vacuum Spring Part No.
½"Hg (-0.02 Bar)	5104-917
1"Hg (-0.03 Bar)	5104-913
1½"Hg (-0.05 Bar)	5104-979

Visual inspection and service (where necessary) is recommended regularly. A detailed step-by-step repair manual is available for our Super Maxi Relief Valves. Please contact our Sales team for further information.



65mm NB Foodgrade Extended Body Relief Valve with 100mm DIN11851 connection - Designed and tested for incompressible fluid flow. Suitable for a pressure range of between 3 - 50 PSI (0.21 - 3.45 Bar) and a standard vacuum setting of 0.5"Hg (0.02 Bar). Contact parts manufactured in 316 stainless steel. Fitted with Forty and EPDM seals.

Options - Additional vacuum settings are available. Valve with 2½" BSP fitting available.

Specification

Weight 6.61 Kg *Varies
 Design Temperature Dependant upon seal material

Design approval by Lloyds Register of Shipping.

Tests may be witnessed and valves individually stamped by an independent inspectorate by arrangement.

Test certificates are supplied as standard.

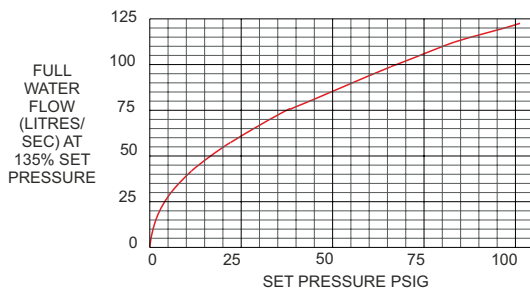

Range

Part No.	Description
0M/5XXXX	Foodgrade relief valve – 100mm DIN11851

Associated Parts

Part No.	Associated Parts
176/2600	100mm DIN11851 milk fitting nut
176/2620	100mm DIN11851 milk fitting socket
176/2900 *	Removable clamped gauze
920/07BBSP	0-100 PSIG pressure gauge, bottom entry, stainless steel internal parts
921/07BBSP	0-100 PSIG pressure gauge, bottom entry, brass internal parts
921/07RBSP	0-100 PSIG pressure gauge, rear entry, brass internal parts

* Fitting ancillary items in the flow stream will affect the valve flow rate.

Fitting Details

Example shown : 0M/5XXXX

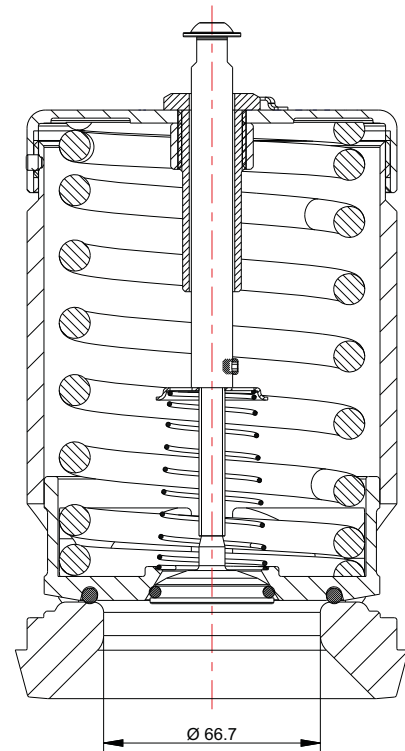
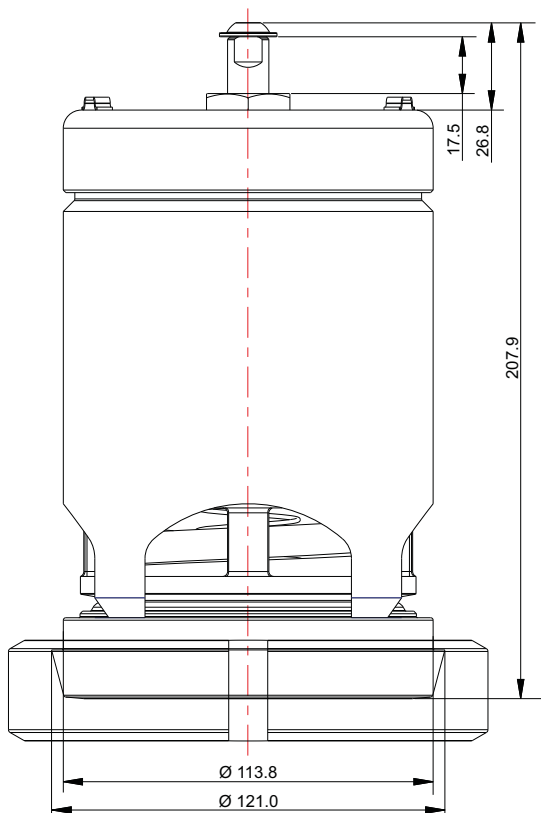

Fitting Details

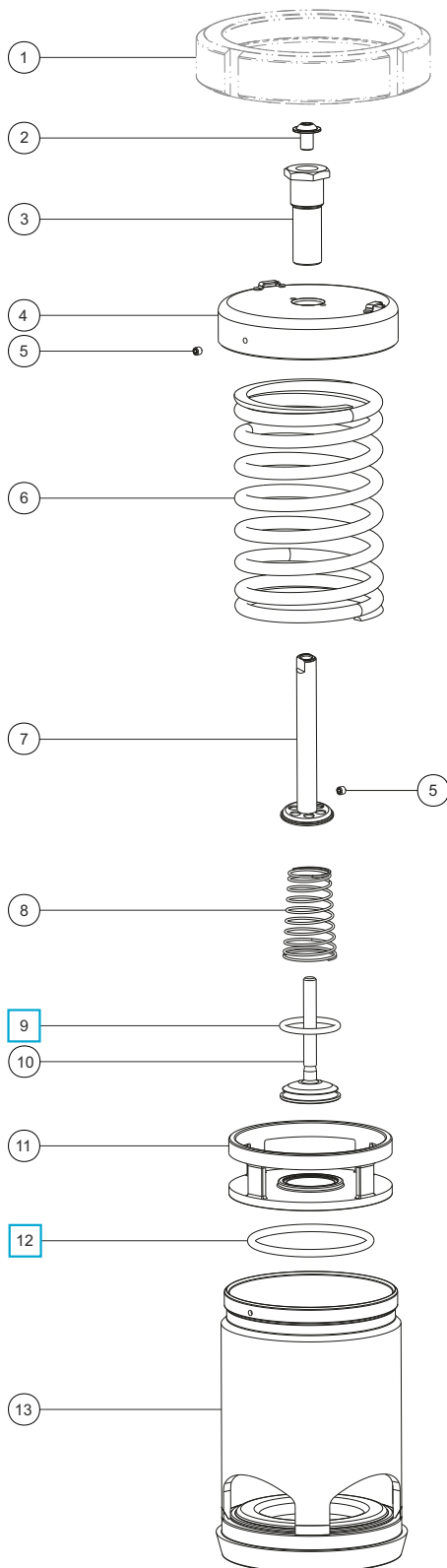

Item	Description	Part No.
1	100mm DIN11851 milk fitting nut *	176/2600
2	Flanged button screw	5111-9812
3	Adjusting screw	175/0005
4	Cap assembly	176/0009
5	Grubscrew (2)	5121-001
6	Pressure spring *See Table 1	5104-XXX
7	Spring pad assembly	176/0067
8	Vacuum spring *See Table 2	5104-XXX
9	EPDM O ring	5005-255 <input type="checkbox"/>
10	Vacuum poppet	230/0045
11	Pressure plate	176/0062
12	Fortyt O ring	5005-101 <input type="checkbox"/>
13	Body assembly	176/0630

* supplied separately

SEAL KIT

Part number **000/5PVSK** contains all parts marked

TABLE 1

Pressure Setting	Pressure Spring	Full Water Flow (Litres/Sec)	At Pressure (PSIG)
17 PSI (1.17 Bar)	5104-922	50.6	23.0
22 PSI (1.52 Bar)	5104-940	57.6	29.7
25 PSI (1.72 Bar)	5104-912	61.4	33.8
26 PSI (1.79 Bar)	5104-912	62.6	35.1
27 PSI (1.86 Bar)	5104-927	63.8	36.5
29 PSI (2.00 Bar)	5104-921	66.1	39.2
32 PSI (2.21 Bar)	5104-921	69.5	43.2
36 PSI (2.48 Bar)	5104-958	73.9	48.6
43 PSI (2.96 Bar)	5104-978	80.5	58.1
44 PSI (3.03 Bar)	5104-978	82.5	59.4

TABLE 2

Common Vacuum Settings	Vacuum Spring Part No.
½" Hg (-0.02 Bar)	5104-917
1" Hg (-0.03 Bar)	5104-913
1½" Hg (-0.05 Bar)	5104-979

Visual inspection and service (where necessary) is recommended regularly. A detailed step-by-step repair manual is available for our Super Maxi Relief Valves. Please contact our Sales team for further information.

Tank Weld-In Socket



Heavy-duty tank weld-in socket with over-size thread to alleviate the need for re-tapping after welding. Available in 1½" BSP and 2½" BSP. Contact parts manufactured in 316 stainless steel.

Description	Part No.
1½" BSP socket	600/1010
2½" BSP socket	600/1000

Cowl



A cowl clamps to the relief valve cap and offers dust protection.

NOTE : Fitting a cowl may affect the valve flow rate.

Description	Part No.
Cowl for 2½" BSP Super Maxi valve	176/6000

Clamped Gauze Ring



A clamped gauze ring fits around the valve body ports and offers flame protection on valves with a vacuum setting of 0.21 Bar (6"Hg) and above. For valves with a vacuum setting of less than 0.21 Bar, a clamped gauze is often fitted to offer dust protection.

NOTE :

Fitting a 176/2900 gauze to a 65mm Super Maxi relief valve reduces flow rate by 1%.

Fitting a 176/2920 gauze to an 043/series or 049/series 80mm Hyper Maxi relief valve reduces flow rate by 5.4%.

176/2900 and 176/2920 are NOT interchangeable

Description	Part No.
Clamped gauze to suit Super Maxi valve	176/2900
Clamped gauze to suit 80mm Hyper Maxi 043/ & 049/ series only	176/2920

Bursting Disc

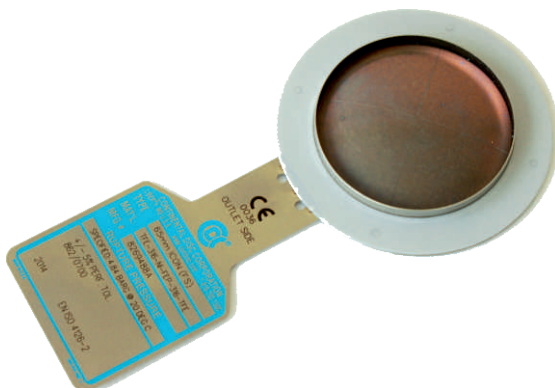

A bursting disc is designed to fit in series with a **pressure only** relief valve. Discs are manufactured to Fort Vale's specifications by a carefully selected disc manufacturer.

NOTE : Fitting a bursting disc reduces valve flow rate.

Description	Part No.
65mm/65mm XL bursting disc	862/XXXXX
80mm bursting disc	864/XXXXX

Please contact our Sales team to discuss your required disc setting.

Tank Gaskets



The tank gasket fits between the 2½" BSP relief valve body and the socket/adaptor flange. The material varies according to the valve specification.

Description	Part No.
EPDM rubber/PTFE envelope gasket	5005-046
CNAF gasket	5005-026
Solid PTFE gasket	5005-027

Pressure Gauge



The pressure gauge fits into the relief valve flange gauge connection and provides a tank pressure reading. Where it is fitted onto a valve mounted in series with a burst disc, it may be used to detect the burst disc integrity. ¼" BSP connection. Pressure range available from 0 to 20 Bar (0 to 290 PSIG).

Description	Part No.
Pressure gauge 0-100 PSIG, bottom entry, stainless steel internal parts	920/07BBSP
Pressure gauge 0-100 PSIG, bottom entry, brass internal parts	921/07BBSP
Pressure gauge 0-100 PSIG, rear entry, brass internal parts	921/07RBSP
Pressure gauge 0-290 PSIG, bottom entry, brass internal parts	921/20BBSP

Super Maxi Burst Disc Adaptor



The burst disc adaptor enables a 2½" BSP female threaded tank socket, reference 600/1000, to receive a burst disc and a threaded valve. Contact parts manufactured in 316 stainless steel.

Description	Part No.
Burst disc adaptor (disc not included)	176/7020

Part Number : 176/3150

To suit a 2½" BSP threaded Super Maxi valve or a 176/7001 adaptor flange with a 65mm/65mm XL bursting disc. Manufactured in 316 stainless steel.

**Associated Parts**

Description	Part No.
Tank weld in flange	176/3150
Gasket	5005-398
Bolt kit	176/7021

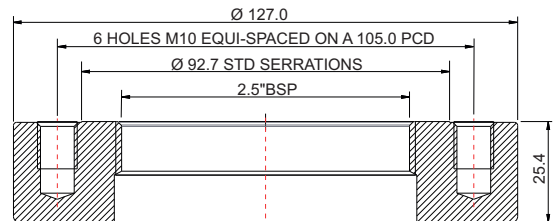
Fitting Details**Part Number : 176/3125**

To suit an 80mm flanged Super Maxi valve with an 80mm bursting disc. Manufactured in 316 stainless steel.

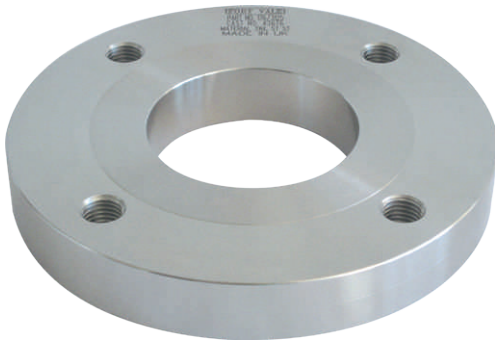
**Associated Parts**

Description	Part No.
Tank weld in flange	176/3125
Gasket	5005-621
Stud kit	311/3700

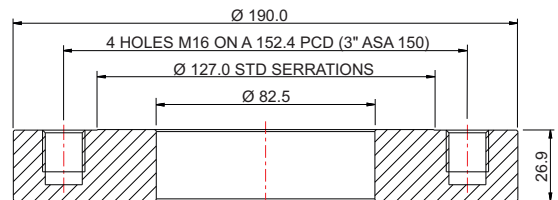
Fitting Details**Part Number : 176/3035**

To suit a 2½" BSP threaded Super Maxi valve with an adaptor flange and a 65mm/65mm XL bursting disc or a 65mm flanged Super Maxi with a 65mm/65mm XL bursting disc. Manufactured in 316 stainless steel.

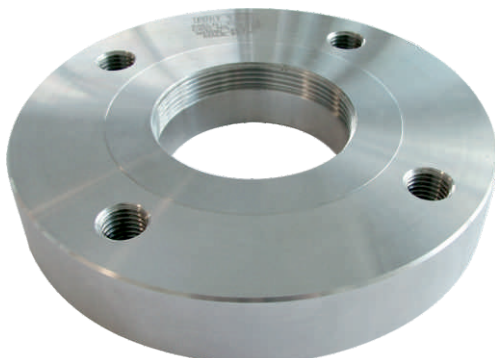
**Associated Parts**

Description	Part No.
Tank weld in flange	176/3035
Adaptor flange	176/3030

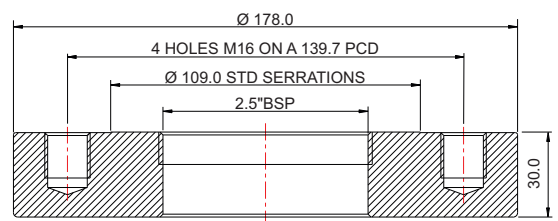
Fitting Details

Part Number : 176/3166

Recessed tank weld-in flange to suit 2½”BSP threaded Super Maxi relief valve. Drilled to match 176/7001 adaptor flange if a bursting disc is required/ Low profile design to lower the overall projection of the valve and to maximise the tank volume within the frame. Manufactured in 316 stainless steel.



Fitting Details

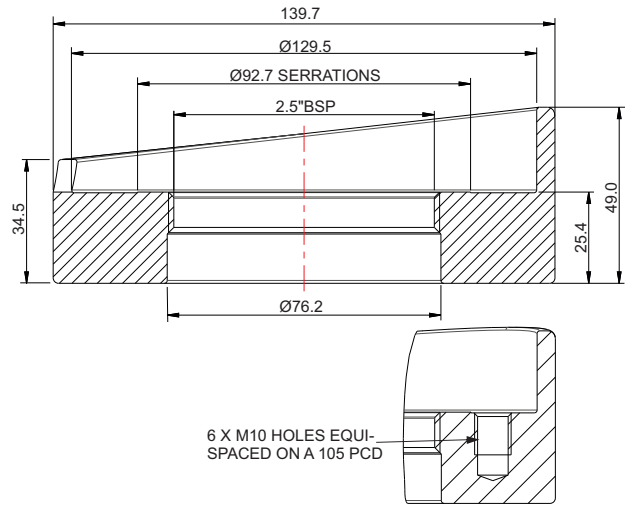

Part Number : S0604

Recessed tank weld-in flange to suit 80mm flanged Super Maxi valve with 80mm bursting disc. Drilled 4 x M16 holes on a 152.4 PCD (3”ASA 150). Manufactured in 316 stainless steel.

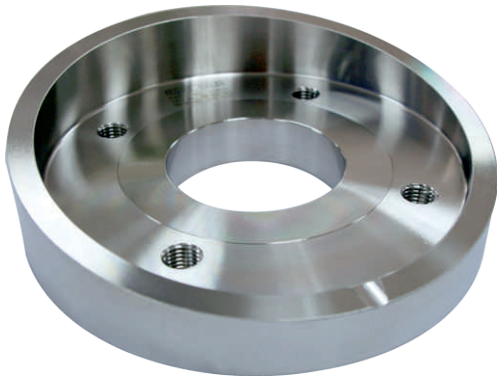

Fitting Details

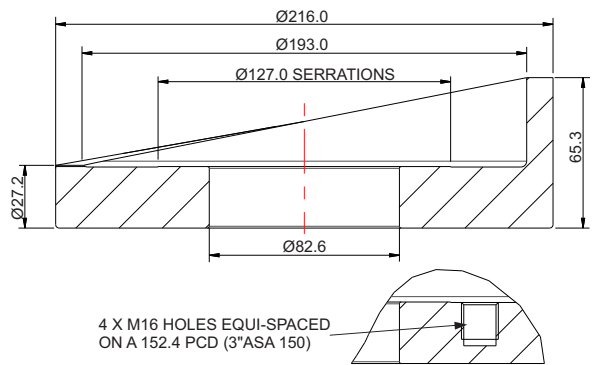

Part Number : 176/7001

Bursting disc adaptor flange with ¼”BSP gauge connection to suit 2½”BSP threaded Super Maxi relief valve. The adaptor is bolted to a tank weld-in flange and accepts a 65mm and 65mm XL burst disc. Manufactured in 316 stainless steel.



Fitting Details

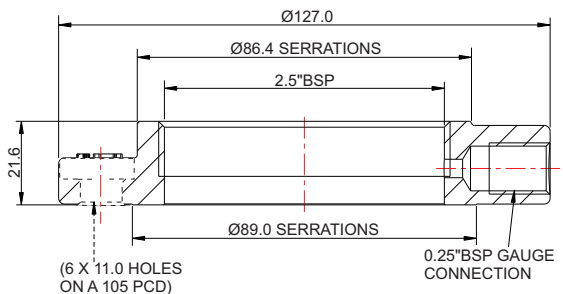

Flanged Super/Hyper Maxi with bursting disc and tank weld-in flange

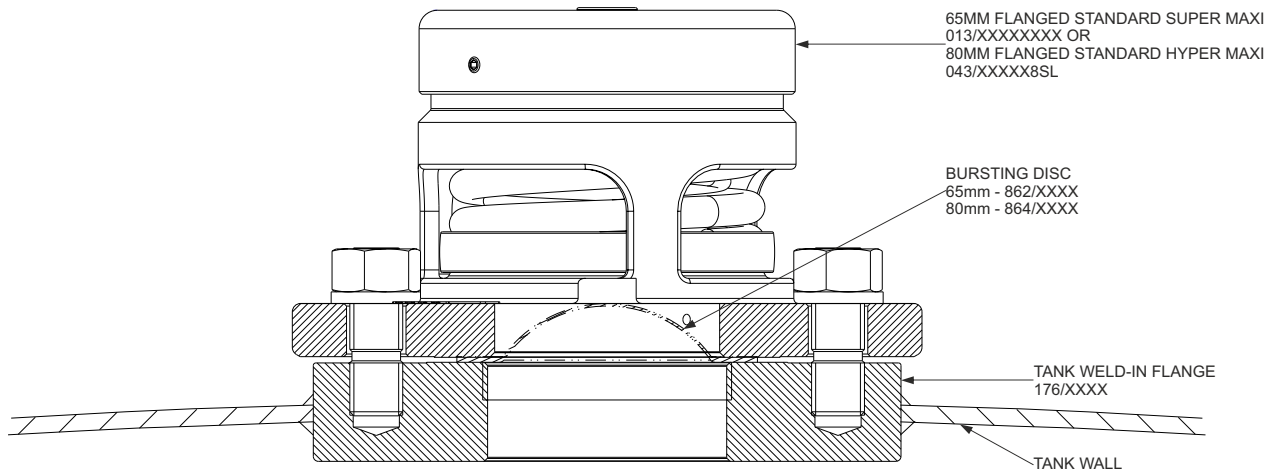

2 1/2" BSP Super Maxi with weatherproof cowl and tank weld-in socket

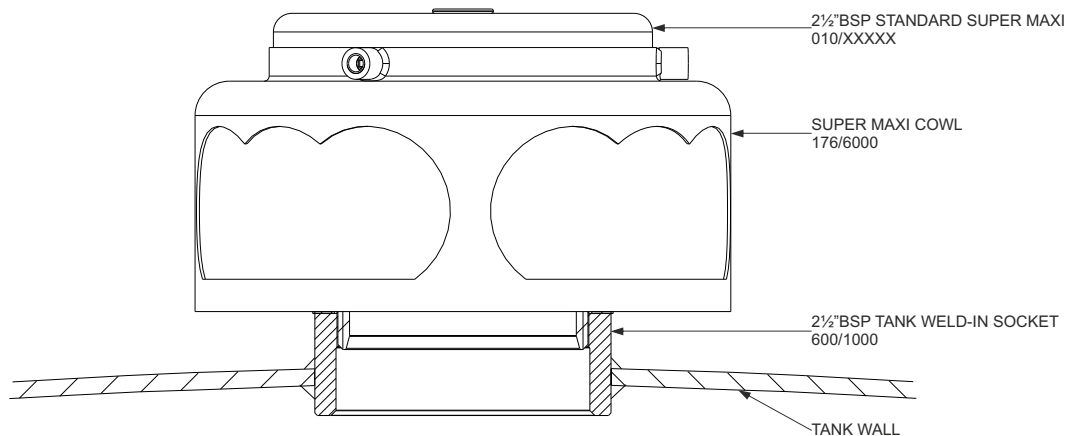

2 1/2" BSP Super Maxi with bursting disc, gauge, adaptor flange and socket

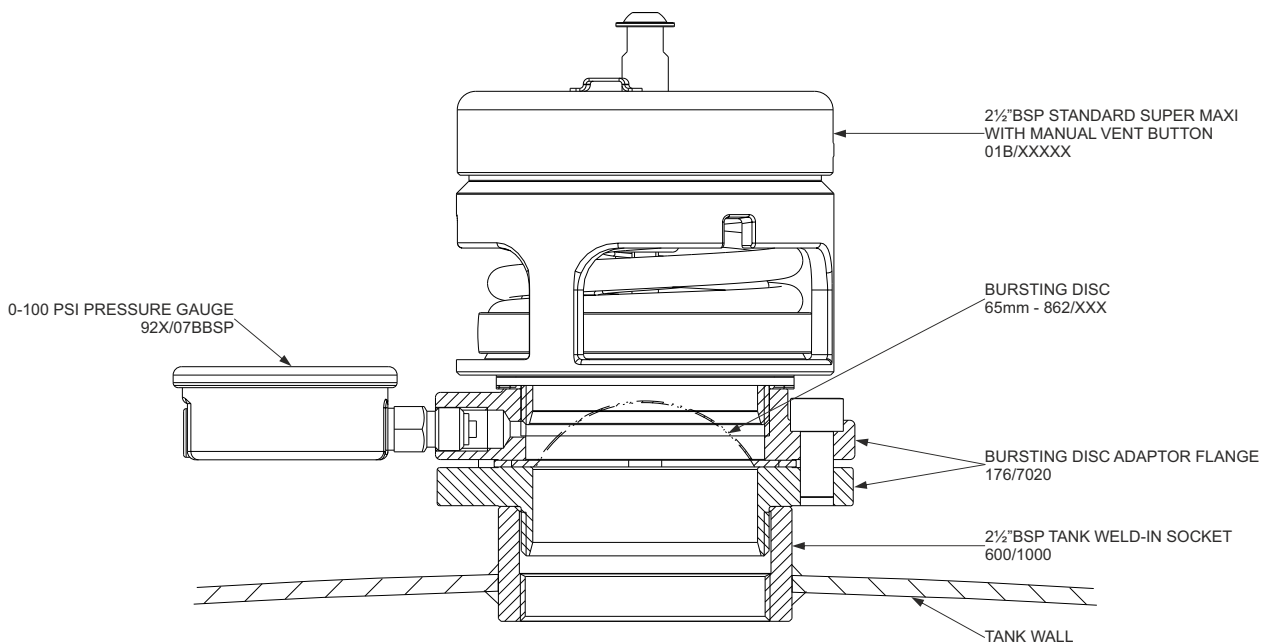



Pressure / Vacuum Test Rig - is used for the testing of any pressure or vacuum Super Maxi, Twinact, Uniact, Minnow and Steam Relief Valve. Connection is by a 2 1/2" BSP socket mounted on top of the rig with adaptors available upon request. The rig comprises of a digital pressure and vacuum gauge and two control valves.

The testing range of the rig is -10 PSI to 100 PSI (-0.7 to 6.9 Bar).

Supply connection to the test rig is via a 1/4" BSP female socket on the back of the rig.

i Operating Instructions available - OPIN26

Fitting Details

Part number : 400/8000

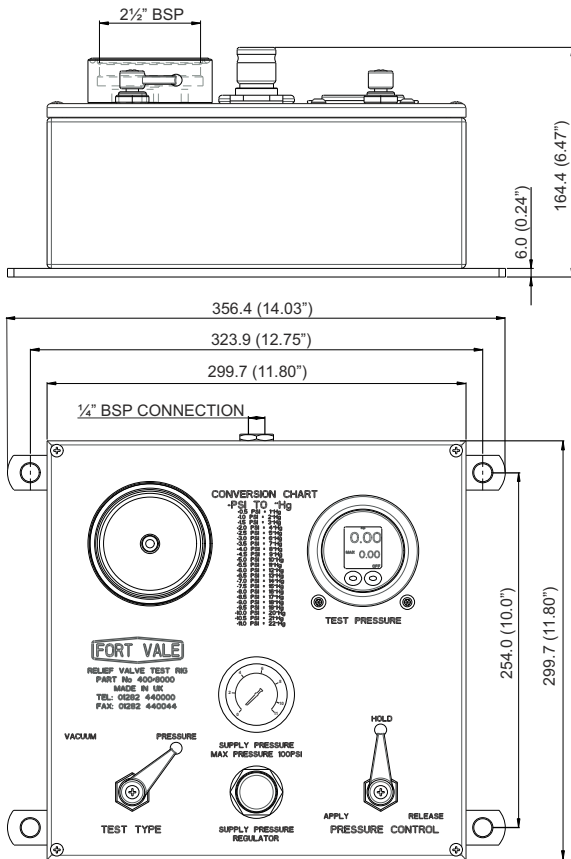

Maintenance Manual

A detailed step-by-step repair manual is available for our Super Maxi Relief Valves in both printed and electronic format. This manual provides details on identification, pressure and vacuum leak tests and refurbishment. A fully laminated printed version is available on request.

Description	Part No.
Super Maxi Relief Valve Maintenance Manual – printed format	MM007
Super Maxi Relief Valve Maintenance Manual – printed & fully laminated	LMM007

Features

- FORT VALE** A supply air filter with auto drain.
- FORT VALE** A pressure regulator and supply air pressure gauge (0-160 PSI).
- FORT VALE** A pressure or vacuum selection control valve.
- FORT VALE** A digital pressure and vacuum gauge.
- FORT VALE** A 3-way control valve incorporating a lap function, which allows the pressure to be held within the valve.
- FORT VALE** A 2 1/2" BSP stainless steel socket for fitting the valves to be tested.
- FORT VALE** A laser marked stainless steel enclosure complete with bench mounting.

Associated Parts

Associated Parts	Part No.
Adaptor flange to suit: 2.5" BSP to DIN65 PN10 2.5" BSP to DIN80 PN6 2.5" BSP to 3" ASA 150	425/1000
2 1/2" BSP X 3" NPTM adaptor	400/8280

Tool Kits

For the maintenance and repair of relief valves, we supply the following tool kits which comprise of all the proprietary tools required to dismantle and re-assemble our range of valves efficiently and quickly, without damaging the seals. For tool kit contents, please contact our Sales office.

Description	Part No.
1 1/2" & 2 1/2" Twinact Relief Valve Tool Kit	400/2000
2 1/2" BSP & Highflow Super Maxi Relief Valve Tool Kit	400/8100
65mm & 80mm Flanged Super Maxi Relief Valve Tool Kit	400/8300
Footvalve & Relief Valve Seat Repair Kit	400/2600



Fort Vale UK
Head Office & Manufacturing Plant

Tel : +44 (0)1282 687120
Fax : +44 (0)1282 687110
Email : sales@fortvale.com

Fort Vale USA

Tel : +1 281 471 8100
Fax : +1 281 471 8116
Email : ussales@fortvale.com

Fort Vale Netherlands

Tel : +31 (0)180 483333
Fax : +31 (0)180 410797
Email : bvsales@fortvale.com

Fort Vale Russian Federation

Tel : +7 916 682 0947
Email : rw@fortvale.ru

Fort Vale P.R. China

Tel : +86 21 6442 1367
Fax : +86 21 6442 1376
Email : cnsales@fortvale.com

Fort Vale Singapore

Tel : +65 6515 9950
Fax : +65 6515 3034
Email : sgsales@fortvale.com

Fort Vale Australia

Tel : +61 7 3310 4854
Email : ausales@fortvale.com

www.fortvale.com

All goods supplied will be subject to Fort Vale Engineering Ltd Terms and Conditions of Sale (Ref. FV4) which are available upon request, or may be viewed at www.fortvale.com.

Please note that this brochure and the contents herein remain the property of Fort Vale Engineering Limited.

This brochure may not be copied or reproduced, or the information contained herein divulged to any third party without the prior written permission of Fort Vale Engineering Limited.

Repair/refurbishment/resetting of Fort Vale valves may be carried out only by trained and authorised personnel. Fort Vale Engineering Limited shall not, in any circumstances, be liable for injuries, losses, expenses or damage, direct or consequential, sustained by the buyer or any person which may in any degree be attributable to the adoption, either by the buyer or any third party, of technical or other information, data or advice given on behalf of Fort Vale Engineering Limited or however otherwise caused in relation to the use of its products in accordance with Fort Vale Engineering Limited's recommendation.

The specifications included in this catalogue are intended to be generic and must be interpreted as equivalent or functionally equivalent. The identification of many items is facilitated by illustrations (photographs and line drawings). The mention of, or reference to specific companies, national standards, or trade names, including those that might appear on the photographs, is intended for illustration purposes only. It does not imply an endorsement, preference or availability of any specific standard, brand or supplier.

The data and information contained herein is being provided for information only and without responsibility, and Fort Vale Engineering Limited makes no representations or warranties, either expressed or implied, as to the accuracy, completeness, or fitness for a particular purpose. Fort Vale Engineering Limited does not accept any responsibility or liability with regard to the reliance on, or use of this data and information.

