



460mm Pennine Manlid Assembly - 6 point double skin cover, hinged to open to 135°. 6mm thick x 100mm deep neckring. Contact parts manufactured in 316 stainless steel with stainless steel swingbolts and handnuts. Seal supplied separately.

Options - 100mm, 150mm, 200mm & 250mm deep neckrings. Neckring profiling available to suit a tank radius range from 850mm to 1220mm. 120° opening. May be supplied fitted with a safebolt. Alternative handnut and hinge kit options available.

Fitting Details

Part number : 42X/6100100A

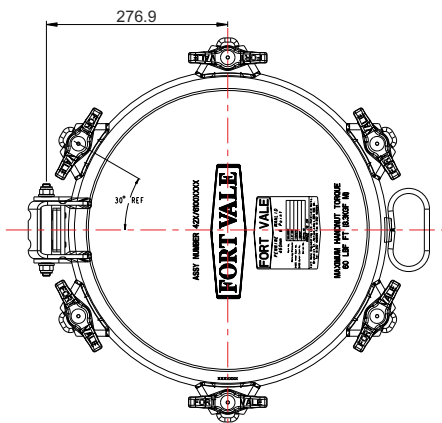
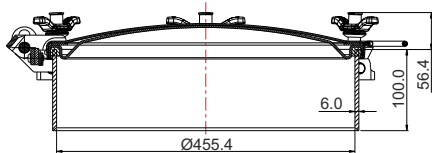

Specification

Weight	30 Kg *See note
Design Pressure (MAWP)	2.67 Bar (38.7 PSI)
Service Test Pressure	4 Bar (58 PSI)
Design Temperature Range	-20°C to 200°C (-4°F to 392°F)
Maximum handnut torque	68 Nm

*NB Weight varies according to specification

Range

Part No.	Description
42X/6100XXXX	Assembly with straight neckring
42X/61XXXXXX	Assembly with profiled neckring

Parts drawing

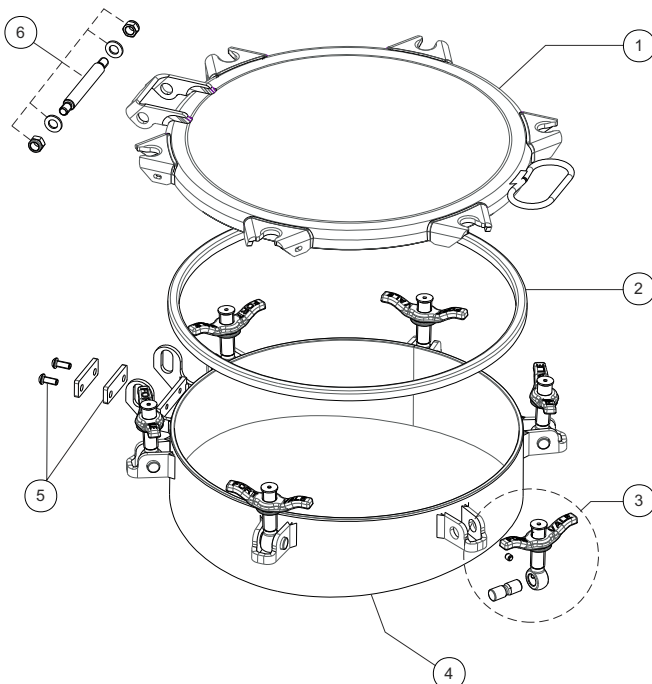

Item	Description	Part No.
1	Manlid	722/0000P
2	Manlid seal	Sold separately
3	Swingbolt assembly (6) *see Note A	496/X342
4	Neckring *see Note B	664/66XXXXA
5	Hinge kit *see Note B	135B
6	Hinge pin assembly	600/1060

Note A

X in swingbolt assembly part number denotes handnut material:

1 = naval brass

5 = stainless steel

E = low profile stainless steel/brass composite

Note B

Part number varies according to specification.