



Specification

Nominal size

DN500

Cover

4 point

Neckring

Thickness: 6mm

Height: 100mm to 300mm

Materials

Contact parts: 316 stainless steel

Fasteners: stainless steel swingbolts with stainless steel handnuts

Seal: supplied separately

Alternatives are available, refer to the Design Options page

Design Conditions

Weight:	30.5 to 45.7 Kg *Note
Design Pressure (MAWP):	1 Bar
Test Pressure:	1.5 Bar
Design Temperature Min:	-40°C
Design Temperature Max:	200°C

NOTE: The specification changes the weight.
The Design Temperature limits refer to metal parts only.
The Design Conditions and Section View dimensions are for the specified part number only.

Design Codes

BS EN 14025

Section View

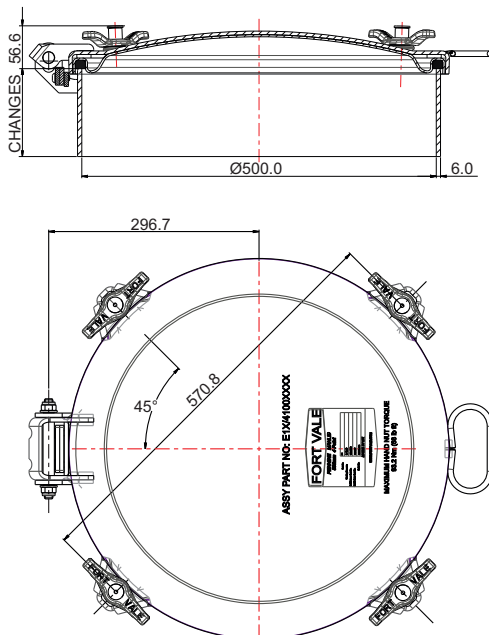

Parts Drawing

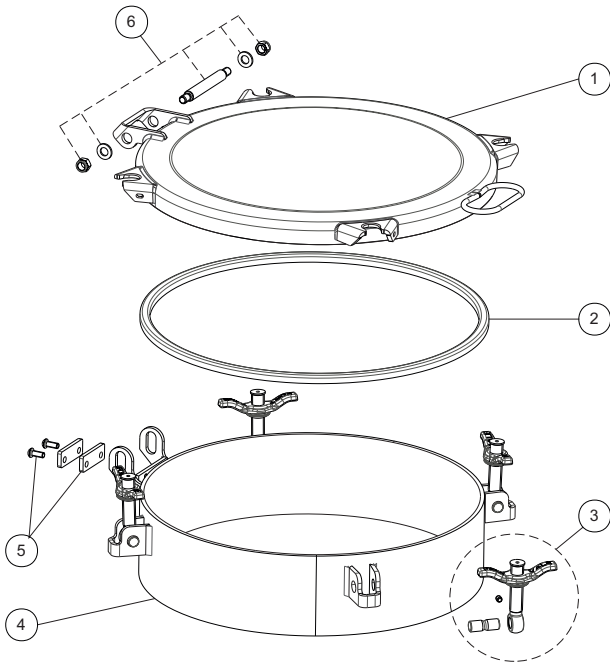

Parts List

Item	Description	Part No.
1	Manlid cover	71E/0500
2	Seal (not included) *Note	5005-50XXX
3	Swingbolt assembly (6)	496/5379
4	Neckring *Note	66E/46XXXA
5	Hinge kit	135B
6	Hinge pin assembly	600/1060

NOTE: The specification changes the Part No.