



Specification

Nominal size

DN450

Cover

6 point

Neckring

Thickness: 6mm

Height range: 100mm to 250mm

Materials

Contact parts: 316 stainless steel

Fasteners: stainless steel swingbolts with naval brass handnuts

Seal: supplied separately

Alternatives are available, refer to the Design Options page

Design Conditions

Weight:	30 Kg *Note
Design Pressure (MAWP):	4 Bar
Test Pressure:	6 Bar
Design Temperature Min:	-40°C
Design Temperature Max:	180°C

NOTE: The specification changes the weight.
 The Design Temperature limits refer to metal parts only.
 The Design Conditions and Section View dimensions are for the specified part number only.

Section View

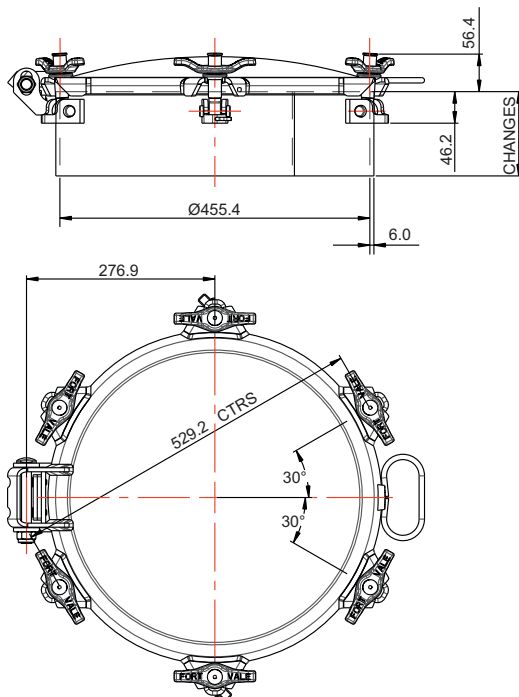

Parts Drawing

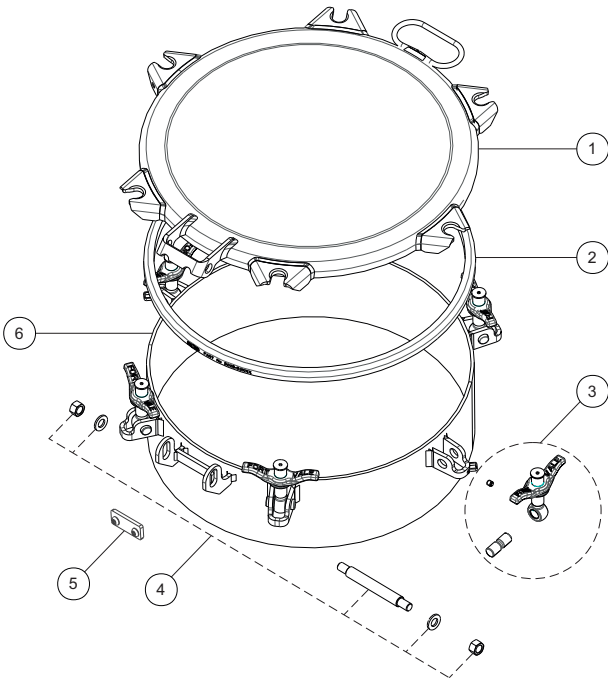

Parts List

Item	Description	Part No.
1	Cover	710/1200P
2	Seal (not included) * Note	5005-XXXX
3	Swingbolt assembly (6)	496/1342
4	Hinge pin assembly	600/1060
5	Hinge kit	135B
6	Neckring * Note	664/66XXXXA

NOTE: The specification changes the Part No.