

Specification

Nominal size/body angle

80mm / 90°

Inlet connection

Flanged: 8 x 14mm holes on a 177.8mm PCD

Properties

80mm footvalve with extended outlet tube, flanged
105mm Drytyt dry disconnect tank unit with pressure-tight cap. Assembly length: 534mm

Materials

Contact parts: 316 stainless steel

Main seal footvalve: Fortyt

Tank unit seal: low temperature Viton

Alternatives are available, refer to the Design Options page

Design Conditions

Weight:	20 Kg *Note
Design Pressure (MAWP):	4 Bar
Test Pressure:	6 Bar
Design Temperature Min:	-40°C
Design Temperature Max:	200°C

NOTE: The valve specification changes the weight. The Design Conditions and Section View dimensions are for the specified part number only.

This assembly is compatible with DNV 2.7-1 Helifuel offshore tanks

Related Parts

Description	Part No.
Weld-in flange	324/9000
M12 stud kit	324/2040
CNAF/PTFE inlet gasket	5005-015
105mm pressure-tight cap, Fortyt seal	915/5480F

Section View

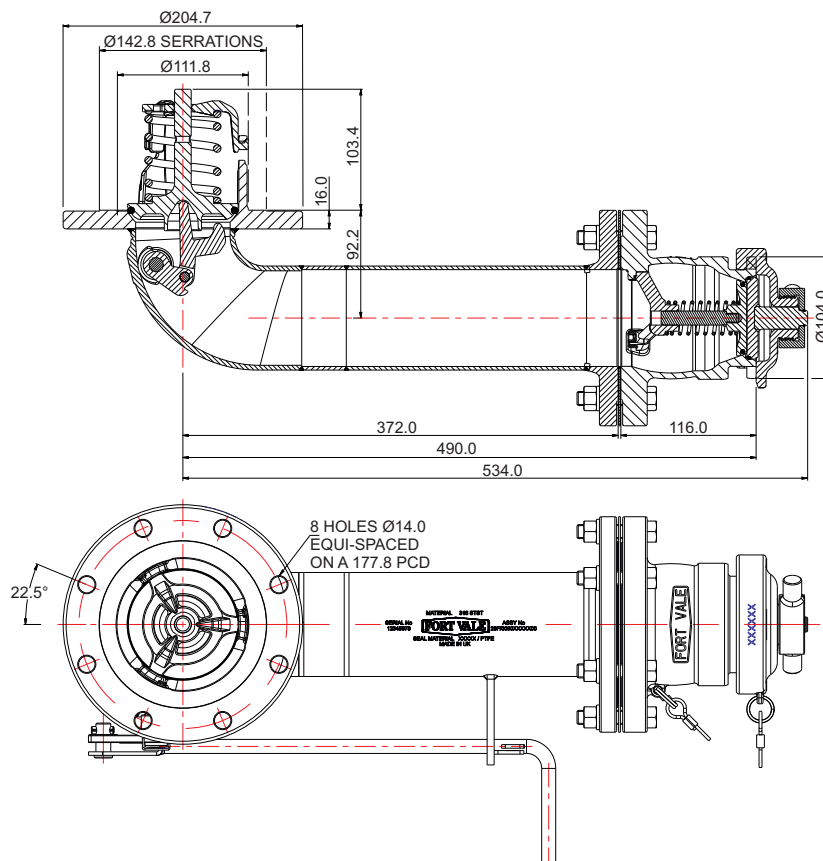

Parts Drawing

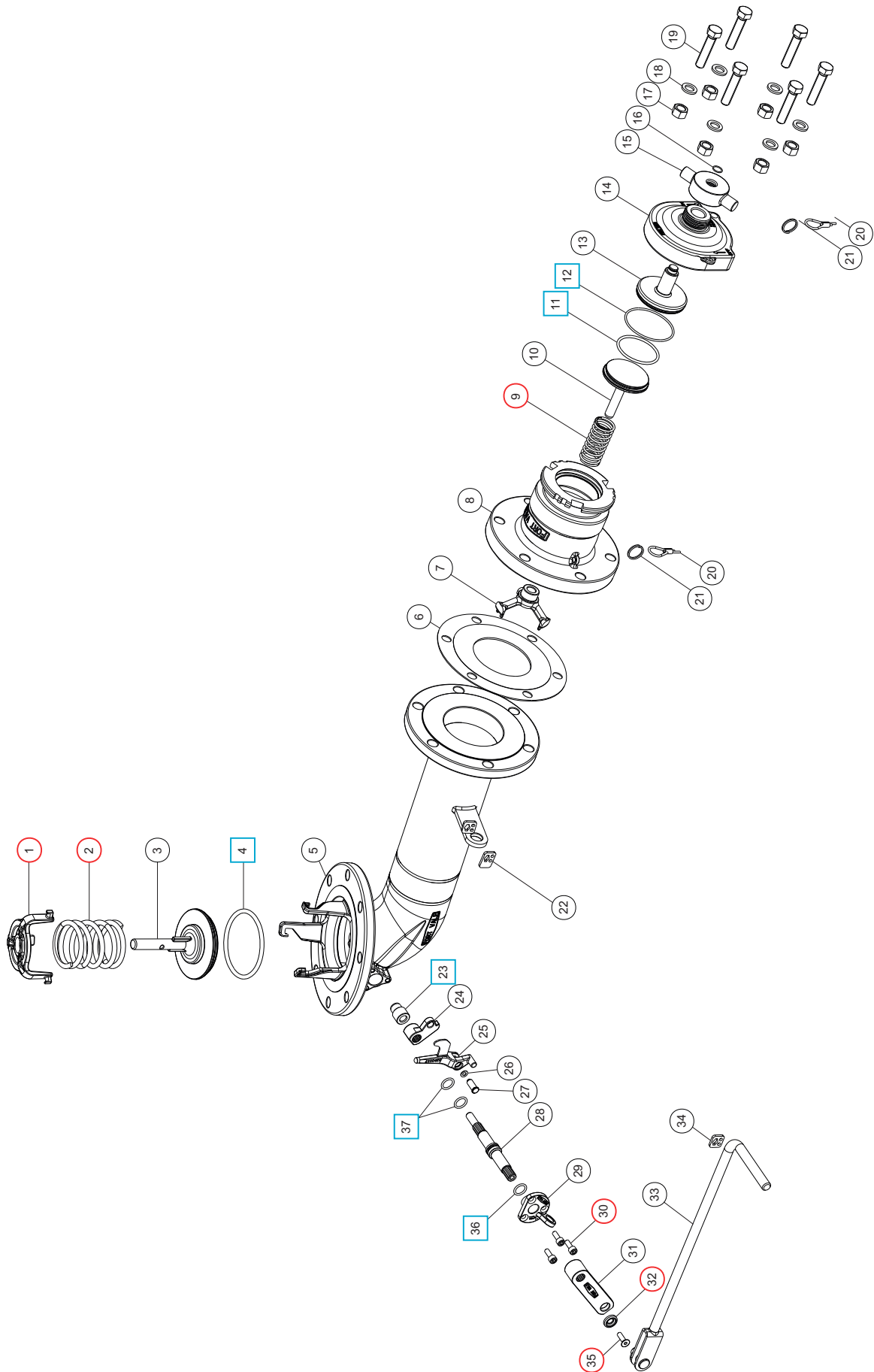

Parts List

Item	Description	Part No.	
1	Spring top plate	290/6104	○
2	Spring	5104-971	○
3	Solid poppet	324/2020	
4	Fortyt O ring	5005-104	□ ○
5	Body weld assembly *Note	28F/XXXXA	
6	CNAF/PTFE gasket	5005-159	
7	Coupling spider	376/1192	
8	105mm coupling body *Note	376/1051EXX	
9	Coupling poppet spring	5104-799	○
10	Coupling poppet *Note	376/1053	
11	Coupling Viton poppet O ring	5005-156	□ ○
12	Cap Fortyt O ring	5005-234	□ ○
13	Cap sealing plate	915/5485	
14	Cap body	915/5481	
15	Top cap	915/5474	
16	Cap circlip	5120-056	
17	M12 full nut (6)	5112-006	
18	M12 spring washer (6)	5113-010	
19	M12 hex bolt (6)	5111-100	
20	2.5mm st/st wire (2)	SF2.5 & 6110-005	
21	Split ring (2)	5128-130	
22	Large TIR plate	20491	
23	Crankshaft end bush	20362	□ ○
24	Crank block	821/0025	
25	Lifting finger assembly	821/0056	
26	5mm plain washer	5113-015	
27	Pivot pin	821/0034	
28	Spindle	821/0010	
29	Stuffing clamp	324/1001	
30	M6 cap screw (3)	5111-017	○
31	Handle (included in item 33)	20607	
32	Retaining washer	20370	○
33	Remote handle	330/5020A	
34	Small TIR plate	20492	
35	6mm countersunk bolt	5111-019	○
36	Viton O ring	20361	□ ○
37	PTFE O ring (2)	20363	□ ○

NOTE: The valve specification changes the Part No.

Seal Kit

Description	Part No.
All parts marked □ in the Parts List	290/53SKA

Repair Kit

Description	Part No.
All parts marked ○ in the Parts List	290/53RK