

Specification

Nominal size/body angle

80mm to 50mm / 90°

Inlet connection

Flanged: 12 x 14mm holes on a 158.75mm PCD

Properties

80mm footvalve with Ø50mm extended outlet tube with 3/4" firesafe sample ball valve and cap, 50mm ball valve with 2" BSP outlet and cap. Assembly length: 834mm

Materials

Contact parts: 316 stainless steel

Main seal footvalve: Fortyt

Main seal ball valve: PTFE

Alternatives are available, refer to the Design Options page

Design Conditions

Weight:	23 Kg *Note
Design Pressure (MAWP):	4 Bar
Test Pressure:	6 Bar
Design Temperature Min:	-40°C
Design Temperature Max:	200°C

NOTE: The valve specification changes the weight. The Design Conditions and Section View dimensions are for the specified part number only.

This assembly is compatible with DNV 2.7-1 chemical offshore tanks

Related Parts

Description	Part No.
Weld-in flange	11954/S
M12 stud kit	290/1300
CNAF/PTFE inlet gasket	5005-016

Section View

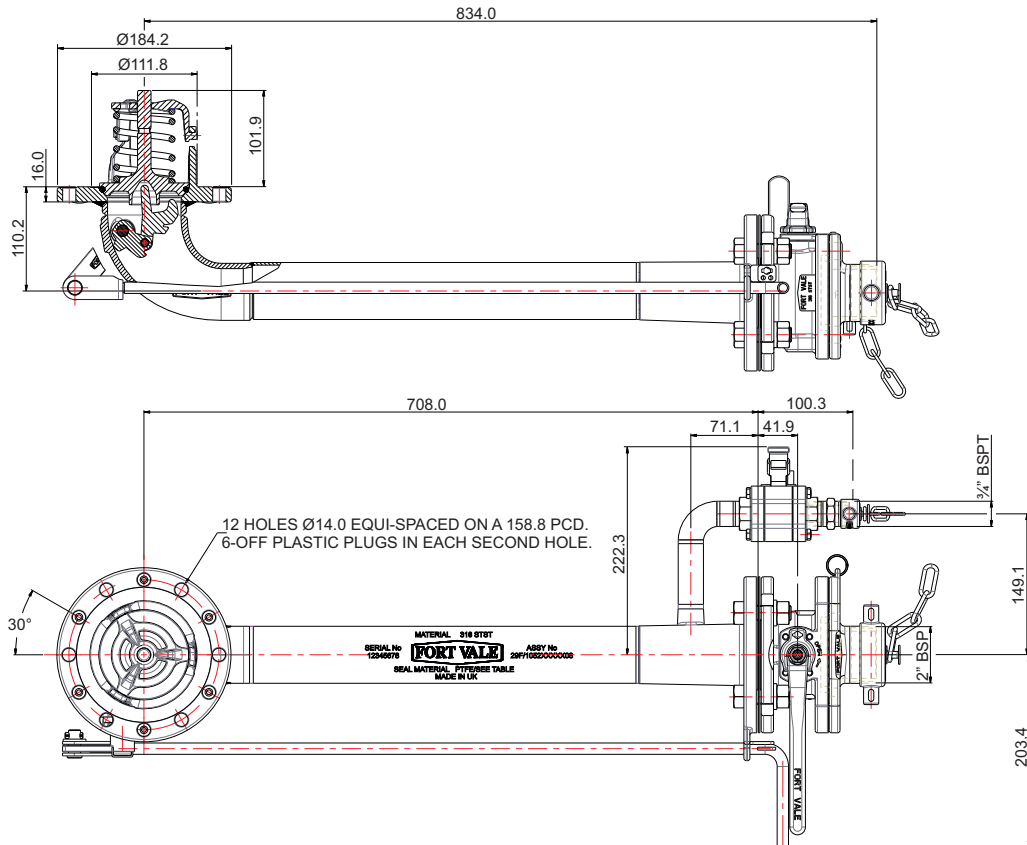

Parts Drawing

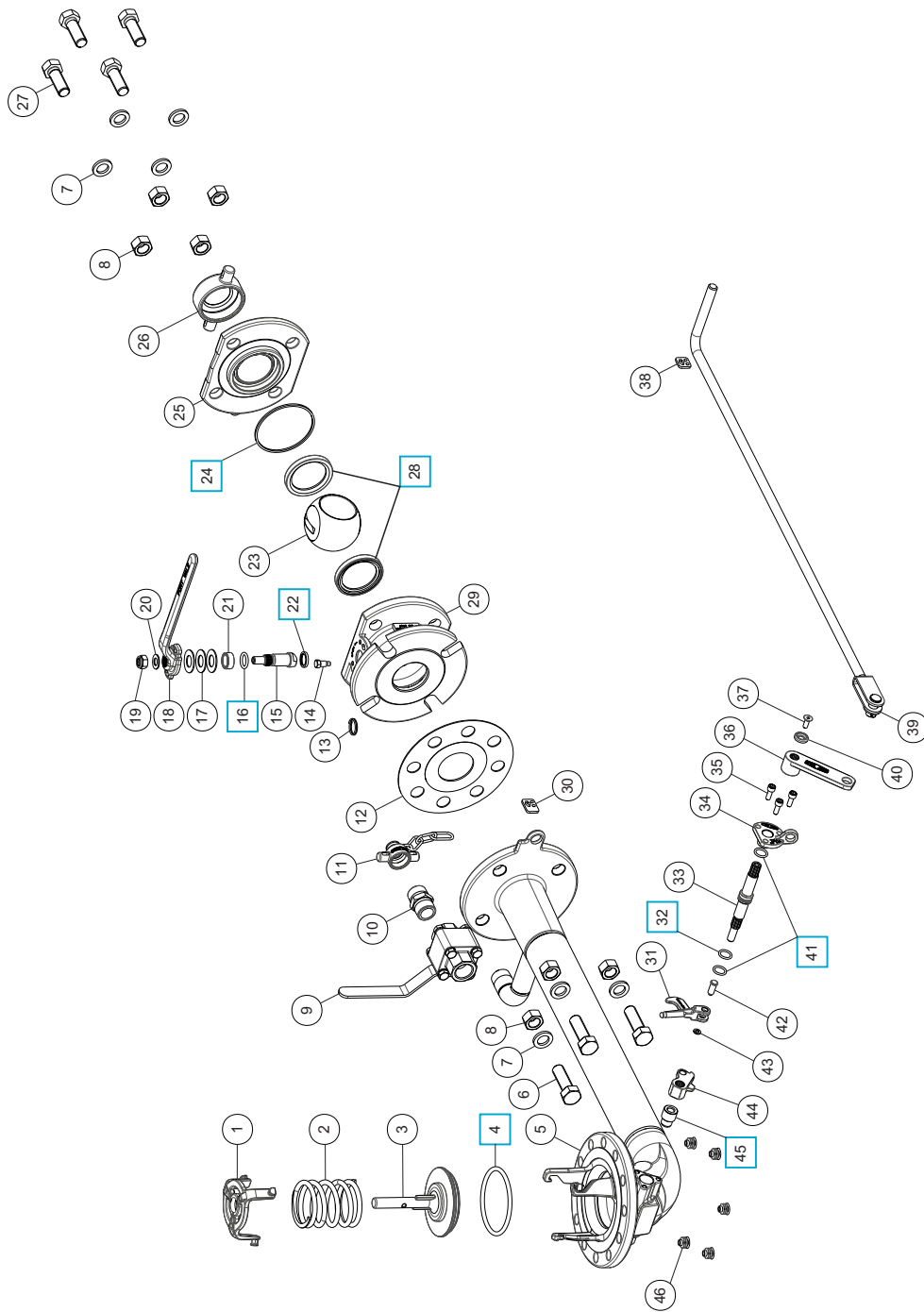

Parts List

Item	Description	Part No.
1	Spring top plate	290/6104
2	Spring	5104-971
3	Solid poppet	324/2020
4	Fortyt O ring	5005-104 ■
5	Body weld assembly *Note	29F/XXXXXA08
6	M16 hex bolt (4)	5111-031
7	M16 spring washer (8)	5113-012
8	M16 full nut (8)	5112-003
9	¾" firesafe ball valve	410/5000F
10	¾" BSPTM/¾" BSPT hex nipple	5128-091
11	¾" BSP cap with washer & chain	10306PSS
12	CNAF/PTFE gasket	5005-726
13	Split ring	5128-013
14	Stop pin	370/0107
15	Spindle	370/0120
16	PTFE O ring	5005-688 □
17	16mm Belleville washer (3)	5113-038
18	Ball valve handle	370/0125
19	M10 self locking nut	5112-008
20	M10 plain washer	5113-009
21	Stuffing collar	370/0103
22	Bottom bearing	370/0104 □
23	50mm ball	370/3301
24	Body seal	370/0106 □
25	Outlet flange	370/0130
26	2" BSP cap with seal & chain	10301PSS
27	M16 hex bolt (4)	5111-036
28	PTFE ball seal (2)	370/0102 □
29	2" ball valve body	370/0110
30	Large TIR tab	20491
31	Extended lifting finger	821/0054
32	Viton O ring	20361 ■
33	Spindle	821/0010
34	Stuffing clamp	324/1001
35	M6 cap screw (3)	5111-017
36	Handle *Note	20607/X
37	M6 countersunk bolt	5111-030
38	Small TIR plate	20492
39	Remote handle *Note	330/5020X
40	Retaining washer	20370
41	PTFE O ring (2)	20363 ■
42	Pivot pin	821/0034
43	5mm plain washer	5113-015
44	Crank block	821/0025/3
45	Crankshaft end bush	20362 ■
46	Plastic plug (6)	5028-227

NOTE: The valve specification changes the Part No.

Seal Kit

Description	Part No.
Ball valve seal kit includes all parts marked □ in the Parts List	370/015SK
Footvalve seal kit includes all parts marked ■ in the Parts List	826/00SK