



Specification

Nominal size/body angle

80mm / 45°

Inlet connection

Flanged: 8 x 14mm holes equi-spaced on a 178mm PCD

Outlet connection

Flanged: 4 x 17mm holes on a 160mm PCD

Properties

2-part body assembly: inlet cassette with poppet and operating assembly; 45° outlet assembly

Materials

Inlet cassette and outlet assembly contact parts: 316 stainless steel with PFA moulded lining

Main seal: Fortyt

Alternatives are available, refer to Range

Design Conditions

Weight:	17.7 Kg
Design Pressure (MAWP):	4 Bar
Test Pressure:	7.3 Bar
Design Temperature Min:	-40°C
Design Temperature Max:	200°C

NOTE: The Design Conditions and Section View dimensions are for the specified part number only.

Design Codes

BS EN 14433

Range

Description	Part No.
3" 45° valve, PFA lined inlet/outlet	845/P1205
3" 30° valve, PFA lined inlet, Halar ® lined outlet	848/P1000
3" 90° valve, PFA lined inlet, Halar ® lined outlet	844/P3000

Related Parts

Description	Part No.
Weld-in flange for lining	324/9000L
Stud kit	845/P128

GASKETS: Do not install an inlet gasket. Do not install a gasket between the inlet cassette and the outlet assembly.

If a Fort Vale PFA lined ball valve or PFA lined butterfly valve is installed to the outlet assembly, do not install an intermediate gasket.

Section View

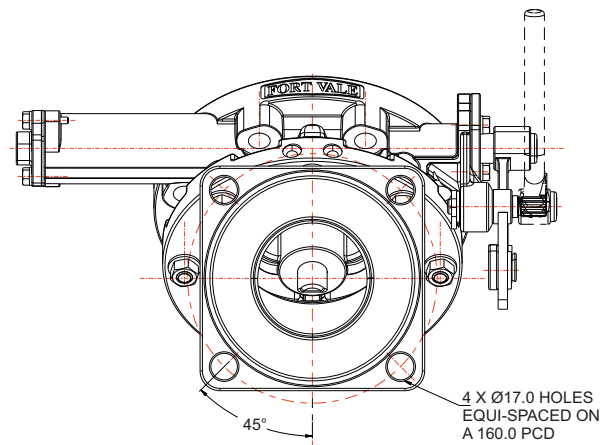
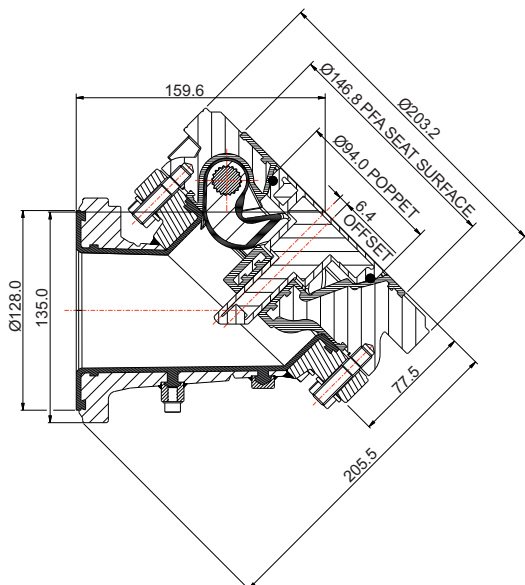

Parts Drawing

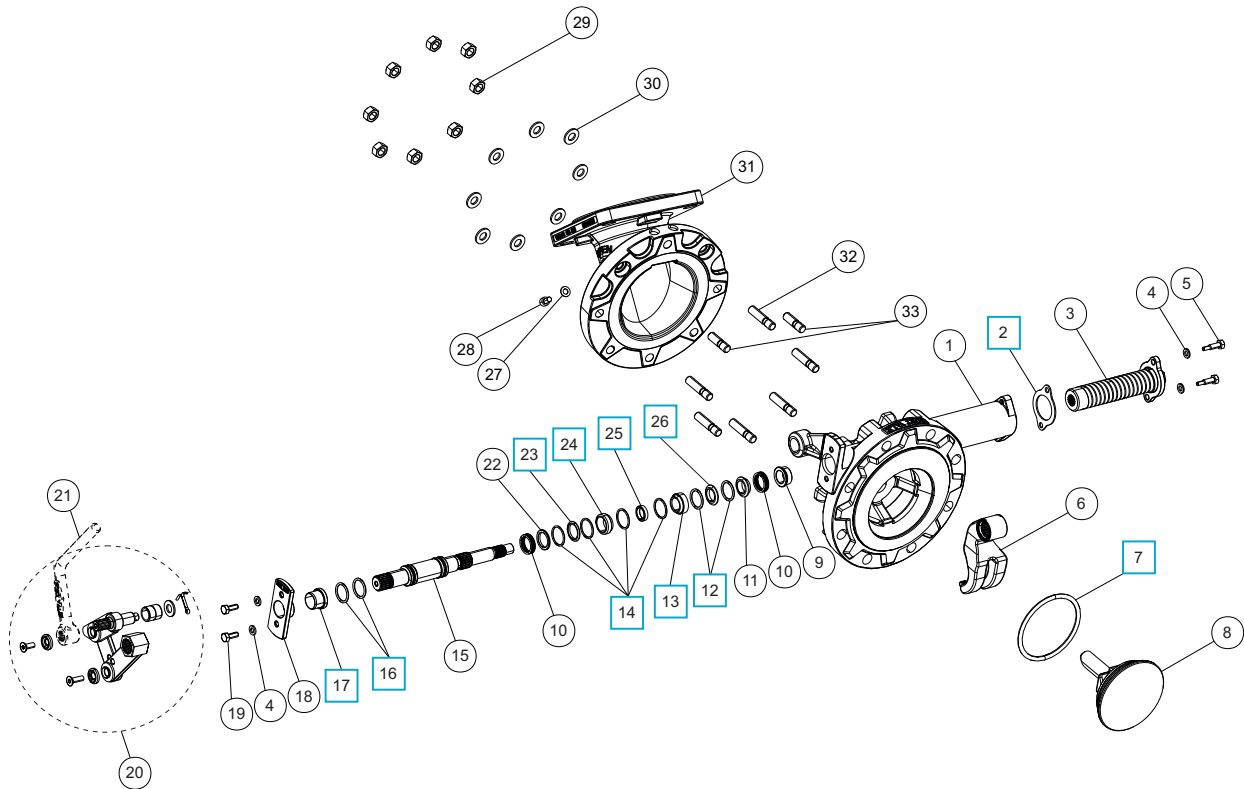

Parts List

Item	Description	Part No.
1	PFA lined body	845/P137LM
2	Spring housing gasket	5005-846 <input type="checkbox"/>
3	Torsion spring assembly	875/0050
4	M6 spring washer (4)	5113-008
5	M6 special hex screw (2)	845/0017
6	PFA lined lifting fork	845/P124L
7	Fortyt O ring	5005-108H <input type="checkbox"/>
8	PFA lined poppet	845/P125LM
9	Spindle bearing	845/P127/3
10	Spirawave spring (2)	5104-027
11	Spring housing bush	845/P127/4
12	Perfluoroelastomer O ring (2)	5005-384 <input type="checkbox"/>
13	Spindle bush	845/P127/2 <input type="checkbox"/>
14	Perfluoroelastomer O ring (4)	ORB020K8 <input type="checkbox"/>
15	Main spindle	845/P126
16	Viton O ring (2)	5005-336 <input type="checkbox"/>
17	RTFE spindle stuffing seal	845/0061 <input type="checkbox"/>
18	Stuffing clamp flange	845/0016
19	M6 x 16mm hex head bolt (2)	5111-022
20	Handle linkage assembly	324/8910
21	Handle - supplied separate	324/8670
22	Wave spring seating washer	845/P127/5
23	Handle side chevron	845/P127/6 <input type="checkbox"/>

Parts List

Item	Description	Part No.
24	Spindle bush	845/P127/1 <input type="checkbox"/>
25	Support ring	845/P127/8 <input type="checkbox"/>
26	Spring side chevron	845/P127/7 <input type="checkbox"/>
27	M6 plain washer	5113-001
28	M6 cap screw	5111-061
29	M10 full nut (8)	5112-002
30	M10 washer (8)	5113-025
31	45° PFA lined outlet assembly	845/P123/45P
32	M10 x 45mm stud (6)	371/0002
33	M10 x 35mm stud (2)	371/0001

Seal Kit

Description	Part No.
All parts marked <input type="checkbox"/> in the Parts List	845/P12SK